

## **Council Retreat Agenda**

- **City Vision / Mission**
- **Financial Update**
- **Fire**
- **Golf**
- **Administrative Services**
- **Tourism / CVB**
- **Community Service Center / WeGo**
- **Police**
- **Parks & Recreation**
- **Recap & Discussion**
- **Adjournment**

Final: Friday, February 19, 2021, 8:00 AM

**Date Submitted:** 2/18/2021  
**Presenter:** Bryan Lackey  
**Item of Business:** • City Vision / Mission  
**Meeting Date:** 2/19/2021

---

**Purpose of Request:**

**History/Background:**

**Facts & Issues for Consideration:**

**Department Recommendation:**

**Department Director:**

---

**If funding is involved, are funds approved within the current budget?**

**Amount Requested:**

**Source of Funds:**

**Finance Comments:**

---

**Administrative Comments:**

---

**ATTACHMENTS:**

Description	Type
<input type="checkbox"/> FY21-22 CMO Retreat Presentation	Powerpoint Presentation



# CITY MANAGER'S OFFICE

## GAINESVILLE CITY COUNCIL RETREAT

2021-22 BUDGET PRIORITIES  
THE STATION – GAINESVILLE ADMINISTRATION BUILDING



# Welcome to The Station

- ▶ City Vision/Mission & CMO (8:30 – 9:15)
- ▶ Financial Update (9:15 – 9:45)
- ▶ Break (9:45 – 10:00)
- ▶ Fire (10:00 – 10:30)
- ▶ Golf (10:30 – 11:00)
- ▶ Administrative Services (11:00 – 11:30)
- ▶ Tourism / CVB (11:30 -12:00)
- ▶ Lunch (12:00 – 12:45)
- ▶ Morning Recap
- ▶ CSC/WeGo (12:45 – 1:15)
- ▶ Police (1:15 – 1:45)
- ▶ Break (1:45- 2:00)
- ▶ Park & Rec (2:00 – 2:30)
- ▶ Afternoon Recap & Discussion (2:30 – until)

# RETREAT AGENDA

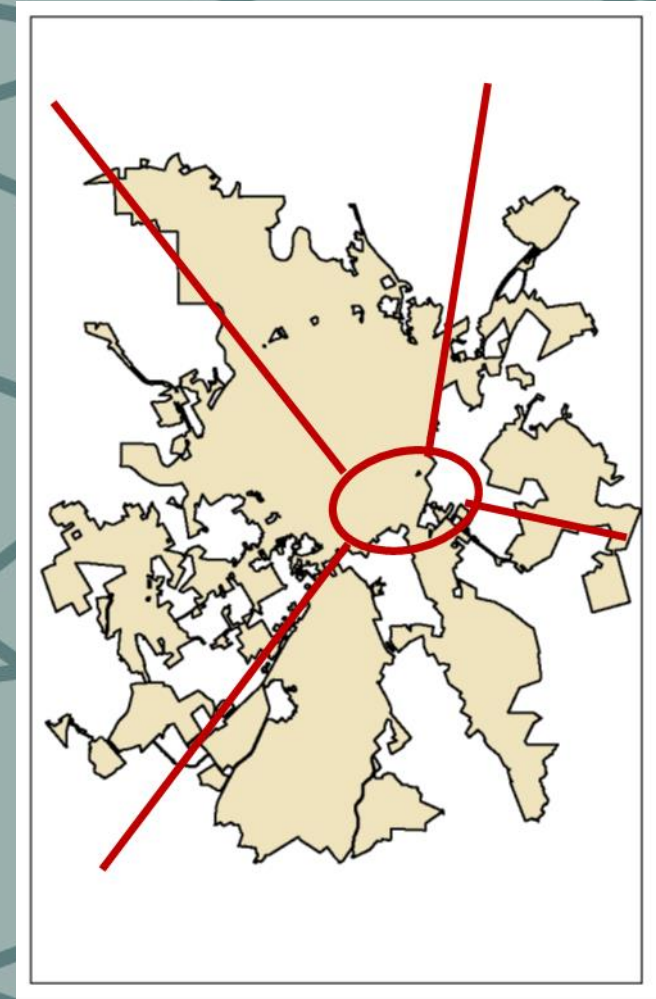

# 2020 Council Retreat Recap



Adjustments for COVID-19 Impacts



Infrastructure/Capital Projects –Paving, Water & Sewer



Traffic Congestion Relief



Public Safety

# 2020 Council Retreat Recap

Roadway Improvements/Resurfacing

Library Parking Deck

Intelligent Transportation System  
Network

I/T Network Upgrades

Memorial Park Dr. / Old Flowery  
Branch Rd. Intersection Design

Maintenance & Upgrades at Flat Creek,  
Linwood, Riverside & Lakeside Plants

Fire Trucks - Pumper X 2

Lift Station Improvements & Sewer Line  
Upgrades/Extensions

Replacement Police Cars

Micro-Transit Vehicles  
(Fully Funded by FTA)

Police & Fire Radio Upgrades

Stormwater Infrastructure

# 2021 Capital Improvements Plan

# VISION, MISSION, VALUES

## Vision

- Gainesville is committed to being an innovative city, providing a close-knit community feel in which to live, work and play.

## Mission

- The mission of the City of Gainesville is to enrich the community of Gainesville by practicing good stewardship of resources and providing innovative and exemplary services for all people.

## Values

- Excellence  
Honesty  
Open Communication  
Commitment  
Stewardship
- Trust  
Accountability  
Leadership  
Quality of Life

# GOAL DEVELOPMENT PROCESS

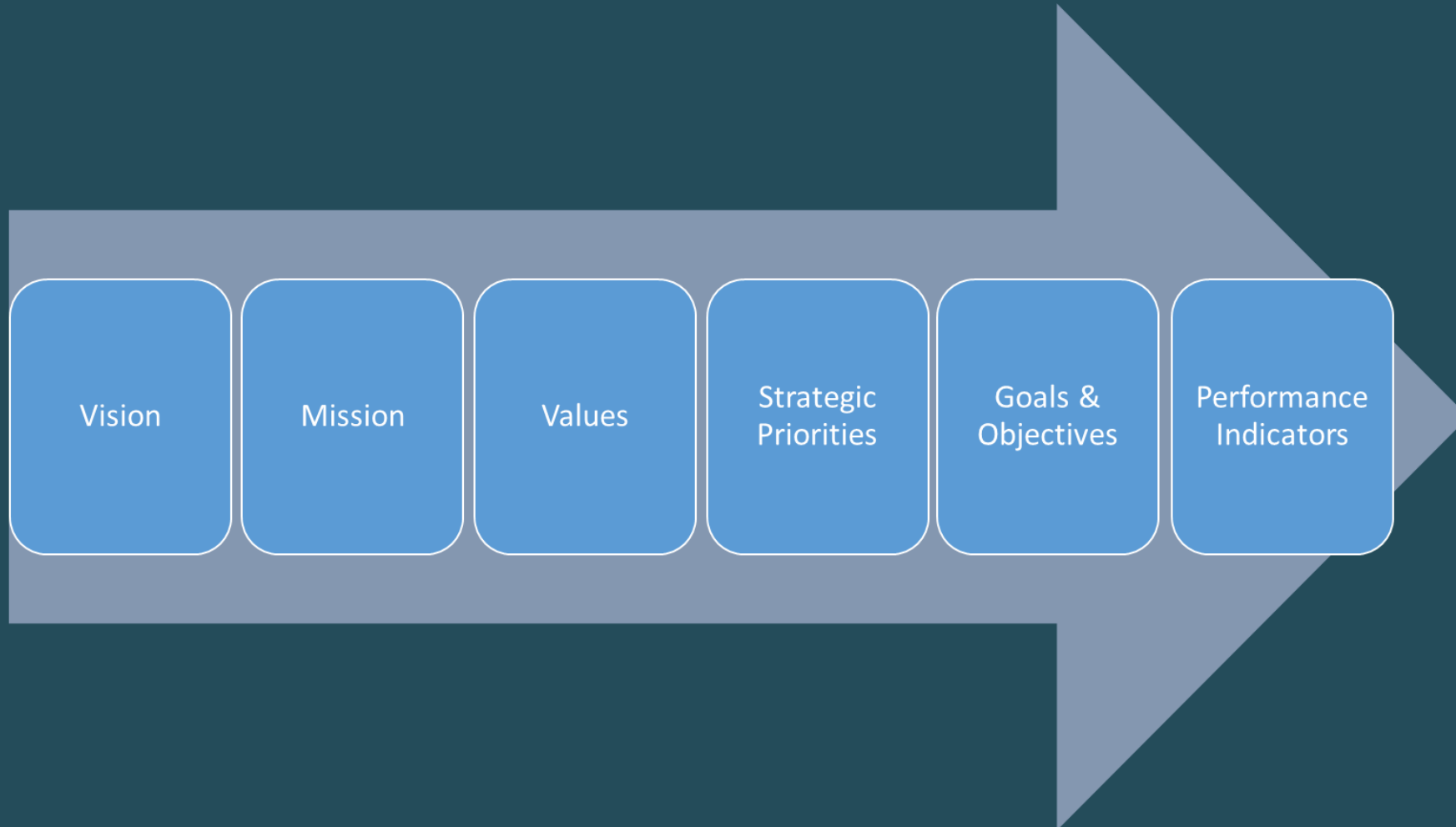

# FOCUS ON STRATEGIC PRIORITIES & CORE SERVICES

## 5 Strategic Priority Categories & Sectors

- Categories
  - Economic Development
  - Infrastructure Improvements
  - Internal Operations
  - Leisure Services
  - Quality of Life
- Sectors
  - Downtown/Midtown
  - South
  - East
  - North
  - West

Think About Your Department's Core Services & How They Relate To These Priorities

# STRATEGIC PRIORITIES

## ECONOMIC DEVELOPMENT

- **Community Development – promote Gainesville as a regional HUB**
- **Support the Implementation of the Downtown Master Plan & the Park Hill Study**
- **New Business Development / Existing Business Support**
- **Encourage/Facilitate private development and redevelopment**
- **Support Economic Development along Employment & Retail Corridors**
- **Maintain ISO rating at Fire Department**
- **Focus on increasing jobs through continued investment in the **identification development** of the next industrial park**
- **Foster revitalization of blighted commercial corridors**

# STRATEGIC PRIORITIES

## INTERNAL OPERATIONS

- **Focus on the Implementation of the I/T Master Plan**
- **Review employee salaries and benefits to evaluate and improve, as needed, to employ and retain a top quality workforce**
- **Encourage departments to work collectively**
- **Develop a Project Management System to expedite capital project initiation and completion**
- **Increase public awareness of City projects, operations and financial position by using multiple methods and outlets**
- **Review internal processes to ensure effectiveness in delivery and efficiency of processes to reach goals**
- **Involve more young people in government**

# STRATEGIC PRIORITIES

## LEISURE SERVICES

- Direct more attention toward services for senior citizens and disabled programs
- Continued support of the Lake Lanier Olympic Park
- Continued commitment to maintain Chattahoochee Golf Club as one of the top Municipal courses in Georgia
- Work with Hall County to improve library services in the downtown area
- Enhanced recreational services for youth ~~(baseball/softball fields)~~
- Continue the development and expansion of the Highlands to Islands Trail
- Incorporate “Urban Leisure” into downtown, midtown and public spaces through the development and/or conversion of plazas and alleyways into desirable and useable space

# STRATEGIC PRIORITIES

## INFRASTRUCTURE IMPROVEMENTS

- Improve Traffic Flow Along Green Street/~~Oak Tree Drive~~
- Address traffic flow along Major Corridors
  - Jesse Jewell Pkwy
  - Dawsonville Hwy
  - E.E. Butler Pkwy
- Resurfacing of City Streets
- Implementation of the Transportation Master Plan
- Improved Sidewalk Network
- Equip traffic signals with fiber and video detection for connection to the City's Intelligent Transportation System
- Make strategic local improvements to upgrade the City's transportation network
- Resolve Cedar Creek/North Oconee issue with County

# STRATEGIC PRIORITIES

## QUALITY OF LIFE

- ~~Signage~~ Branding Implementation
  - ~~“Welcome to Gainesville” signs at entrances to the City~~
  - ~~Way finding signage~~
- Beautification of public areas including right of ways
  - Landscaping Plan for City corridors and downtown square
  - Enhance landscaping on Midtown Greenway
  - Beautification of gateways
  - Incorporate Art into public spaces and/or private development
- Focus on Initiatives that remove commercial and residential blight
  - Code Enforcement
  - ULDC Updates
  - Support Housing Authority & Housing Programs
  - Land Bank
- Code Enforcement / Neighborhood Protection
- Improve the 129 South entrance to Gainesville (infrastructure, clean up, business development)
- Streetscapes into and out of Square along Washington and Bradford Streets

# STRATEGIC PRIORITIES

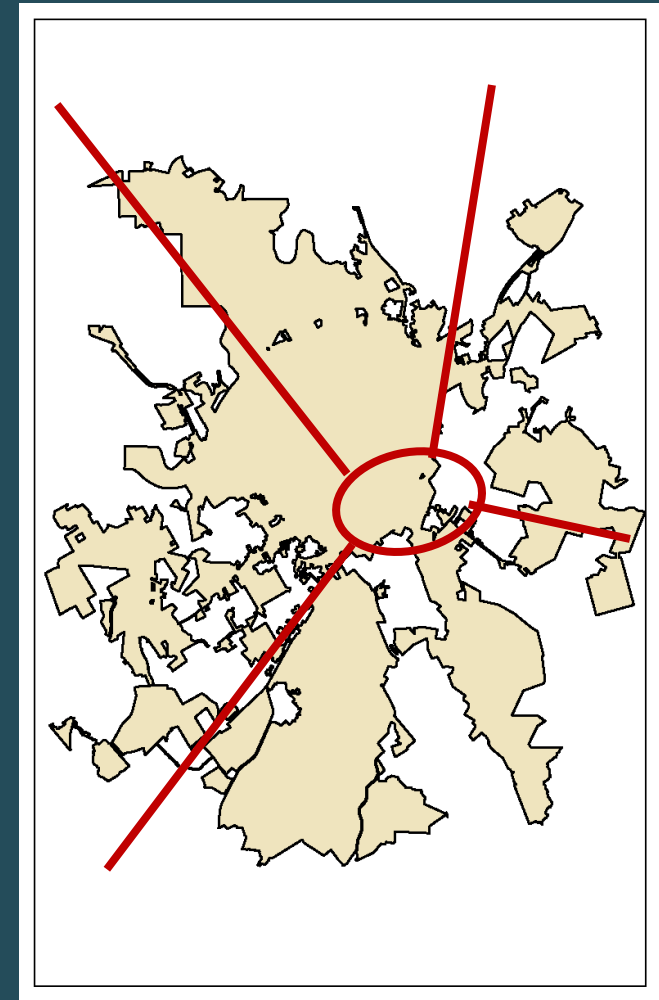

# FOCUS ON STRATEGIC PRIORITIES & CORE SERVICES

- New Initiatives for FY22
- Where Does Our Focus Need To Be?

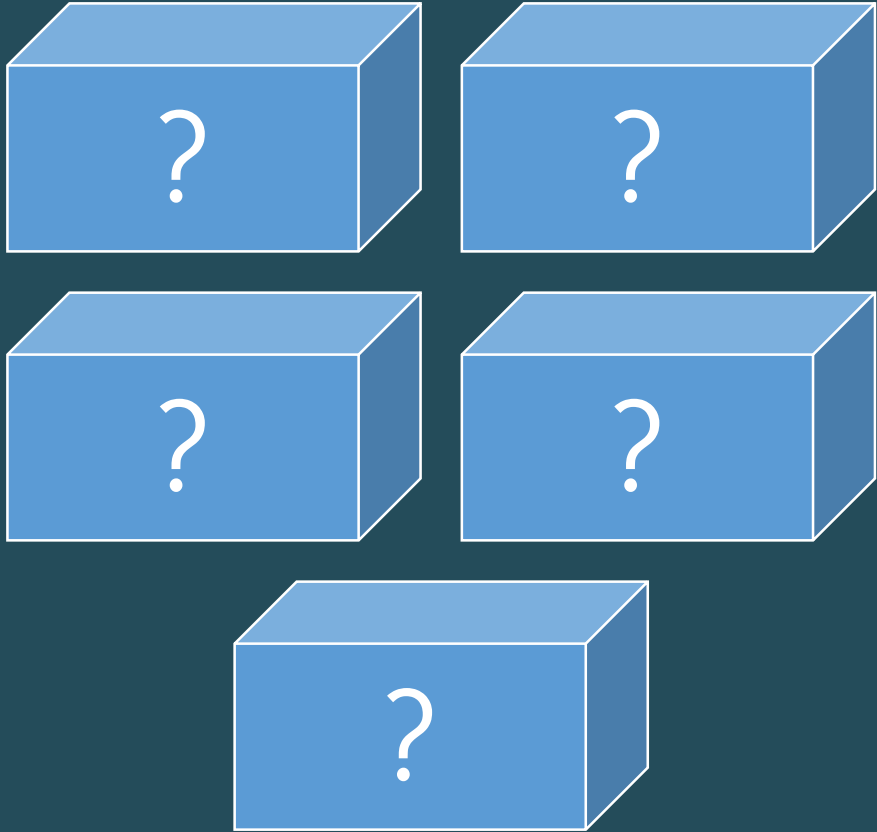



# ACCOMPLISHMENTS

# Green Street Design RFP



# Solis & Renaissance



North  
Downtown  
Parking  
Deck  
Design and  
CM@Risk  
GC





# Completion of Admin Bldg Renovations

# CURRENT DISCUSSION: ACCOMPLISHMENTS

## Park Hill Study

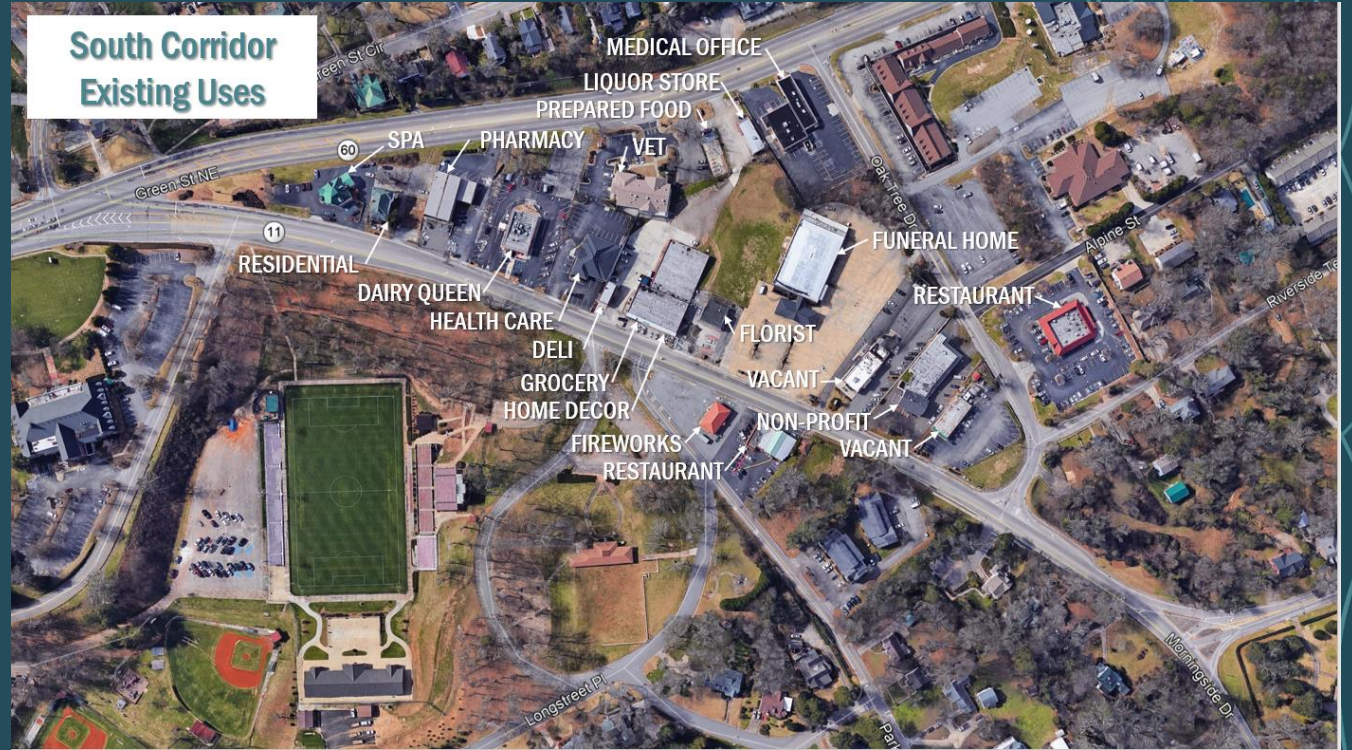

**BUDGET PRIORITY: ECONOMIC DEVELOPMENT | STRATEGIC AREA: NORTH**

# DIGITAL MESSAGING

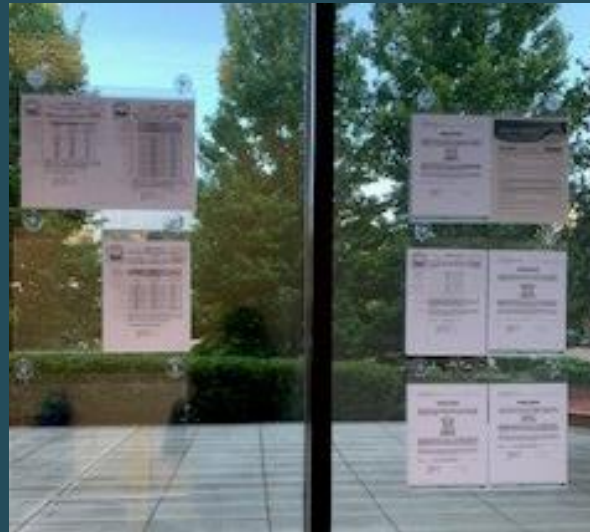

# CURRENT DISCUSSION: ACCOMPLISHMENTS



President  
Vince Williams  
Mayor, Union City

First Vice President  
Jim Thornton  
Mayor, LaGrange

Second Vice  
President  
Julie Smith

Third Vice President  
Michelle Cooper Kelly  
Mayor Pro Tem,

Immediate Past  
President  
Phil Best

Executive Director  
Larry H. Hanson

January 5, 2021

Mayor Danny Dunagan  
City of Gainesville  
P.O. Box 2496  
Gainesville, GA 30503

RE: GMA Certified Cities of Ethics Program

Dear Mayor,

Congratulations, the GMA Ethics Certification Committee has determined that the City of Gainesville meets the qualifications to be recertified as a Georgia Certified Cities of Ethics.

We will officially recognize the city's continuing participation in this program at the 2021 Cities United Summit on Monday, January 25, 2021 during the Awards Ceremony. Your city is one of many in the state that has met the requirements for recertification and will be recognized during the Awards Ceremony. In addition, the names of each of the cities will appear on a special Awards presentation.

We appreciate the City of Gainesville's participation in this important program. If you have any questions about recognition at the 2021 Cities United Summit, please contact Gina Gresham by emailing [rgresham@gacities.com](mailto:rgresham@gacities.com).

Sincerely,

*Rusi Patel*

Rusi Patel  
General Counsel

C: Denise Jordan, City Clerk

# CAMPAIGN FINANCE SOFTWARE



# New City branding



# CURRENT DISCUSSION: ACCOMPLISHMENTS

Launched  
hALL IN  
campaign

Hall County, Gainesville, GA | Off: x +  
wearehallin.com

Create an Account - Increase your productivity, customize your experience, and engage in information you care about. Sign In

# hALL IN

"Are you hALL in? Help us #stopthespread of COVID-19 in the Gainesville-Hall County community by taking the hALL in pledge today."

### What does it mean to be hALL in?

Join our community-wide initiative to encourage the use of masks and other best practices as outlined by the Centers for Disease Control, White House and State of Georgia in order to stop the spread of COVID-19.

Take the Pledge

### Who's hALL in?

Click the link to find out which Hall County organizations have taken the hALL in pledge, an initiative to keep our community safe during the COVID-19 pandemic.

View Pledges

Select Language

BUDGET PRIORITY: INTERNAL OPERATIONS | STRATEGIC AREA: CITYWIDE

# CURRENT DISCUSSION: ACCOMPLISHMENTS

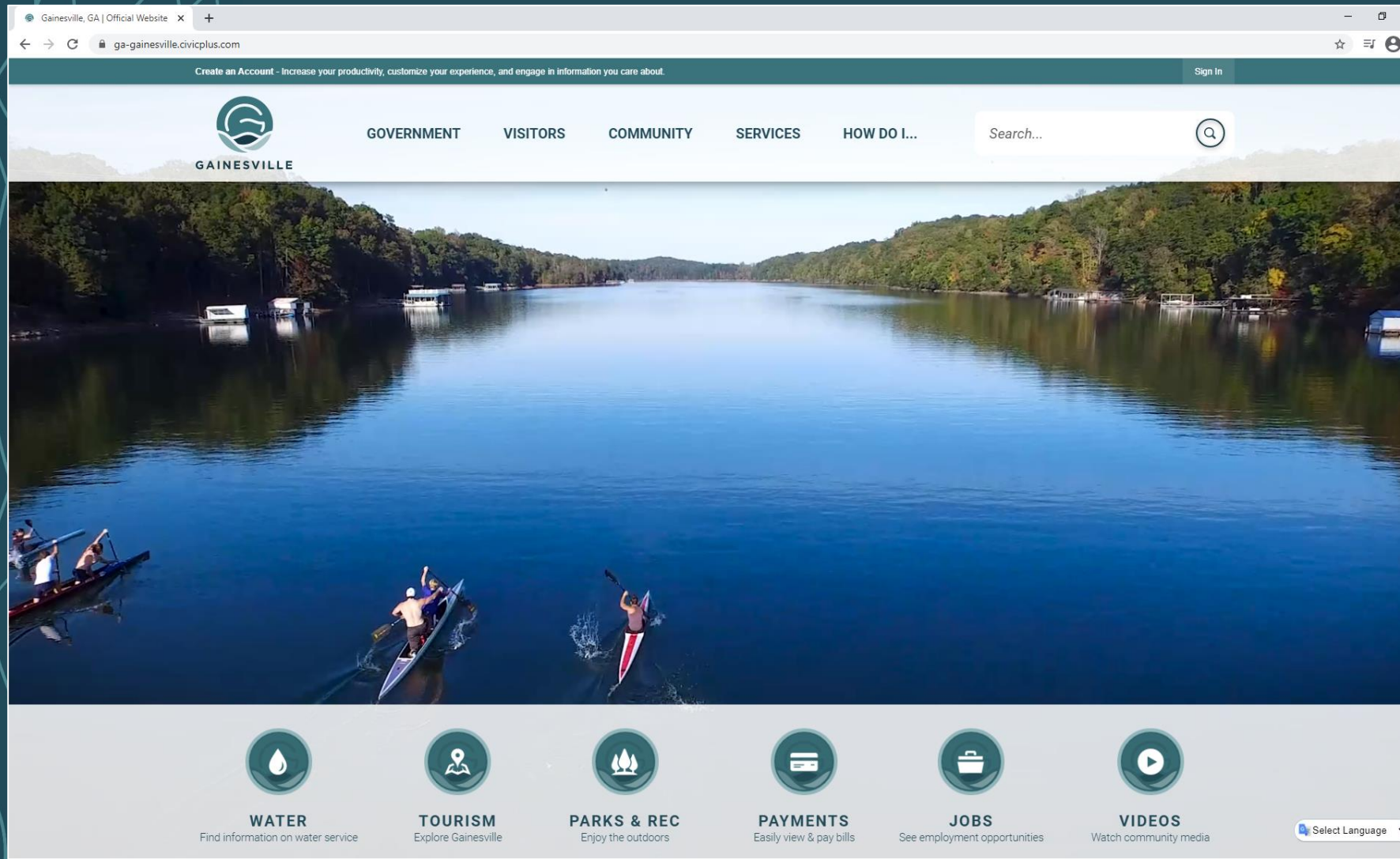

**NEW**  
City  
website  
*gainesville.org*

**BUDGET PRIORITY: INTERNAL OPERATIONS | STRATEGIC AREA: CITYWIDE**

Create an Account - Increase your productivity, customize your experience, and engage in information you care about.

Sign In



GAINESVILLE

GOVERNMENT

VISITORS

COMMUNITY

SERVICES

HOW DO I...

Search...





# CHALLENGES + OPPORTUNITIES

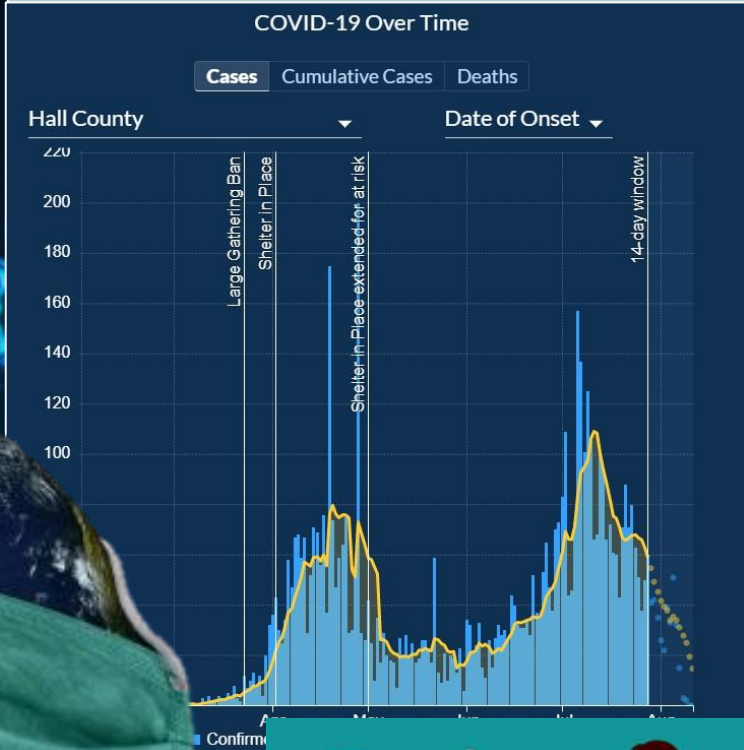
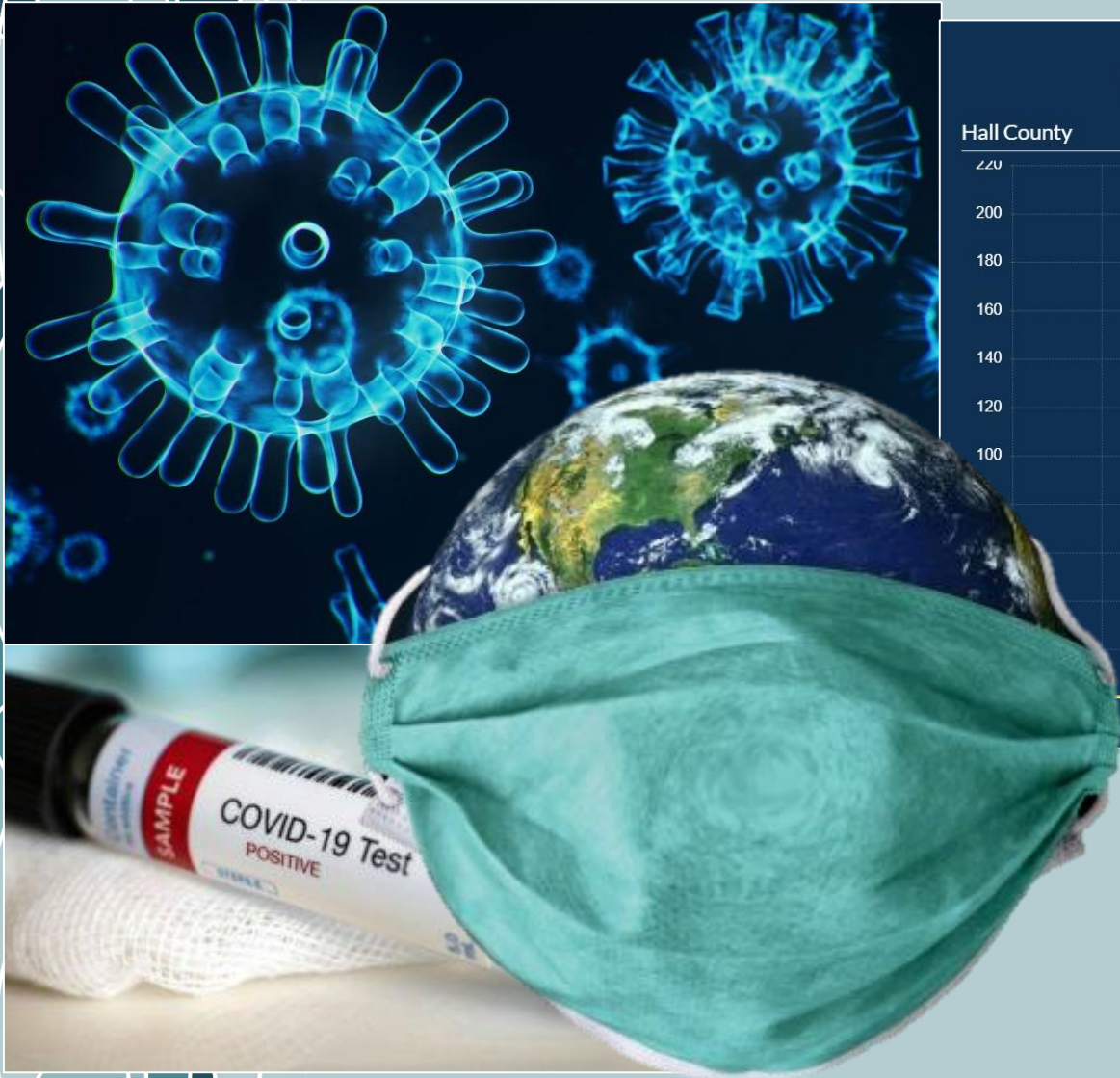

# COVID-19 Pandemic

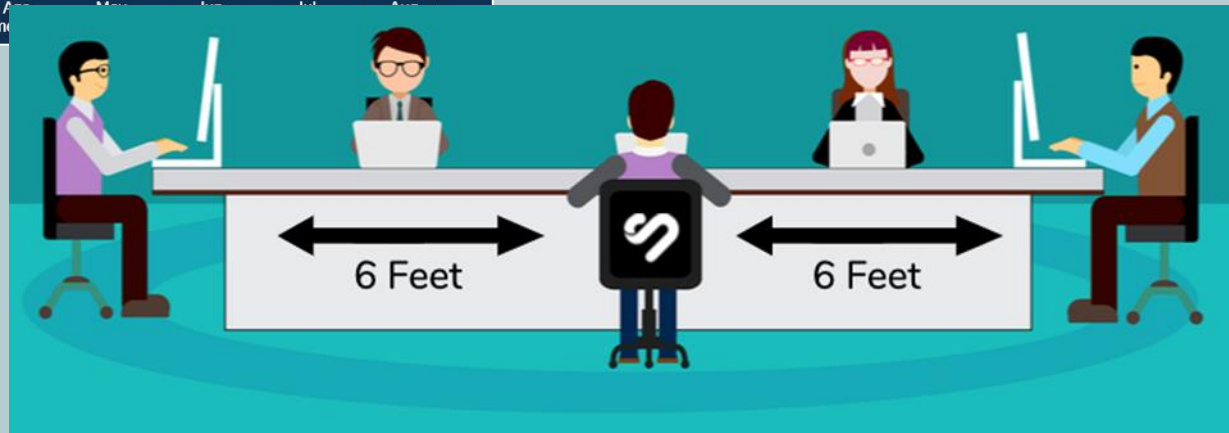

# The Next 5 Years





THE NEXT  
PHASE OF  
DOWNTOWN –  
SQUARE(S),  
ALCOHOL, ETC

# OLD FIRE STATION #2





# INITIATIVES

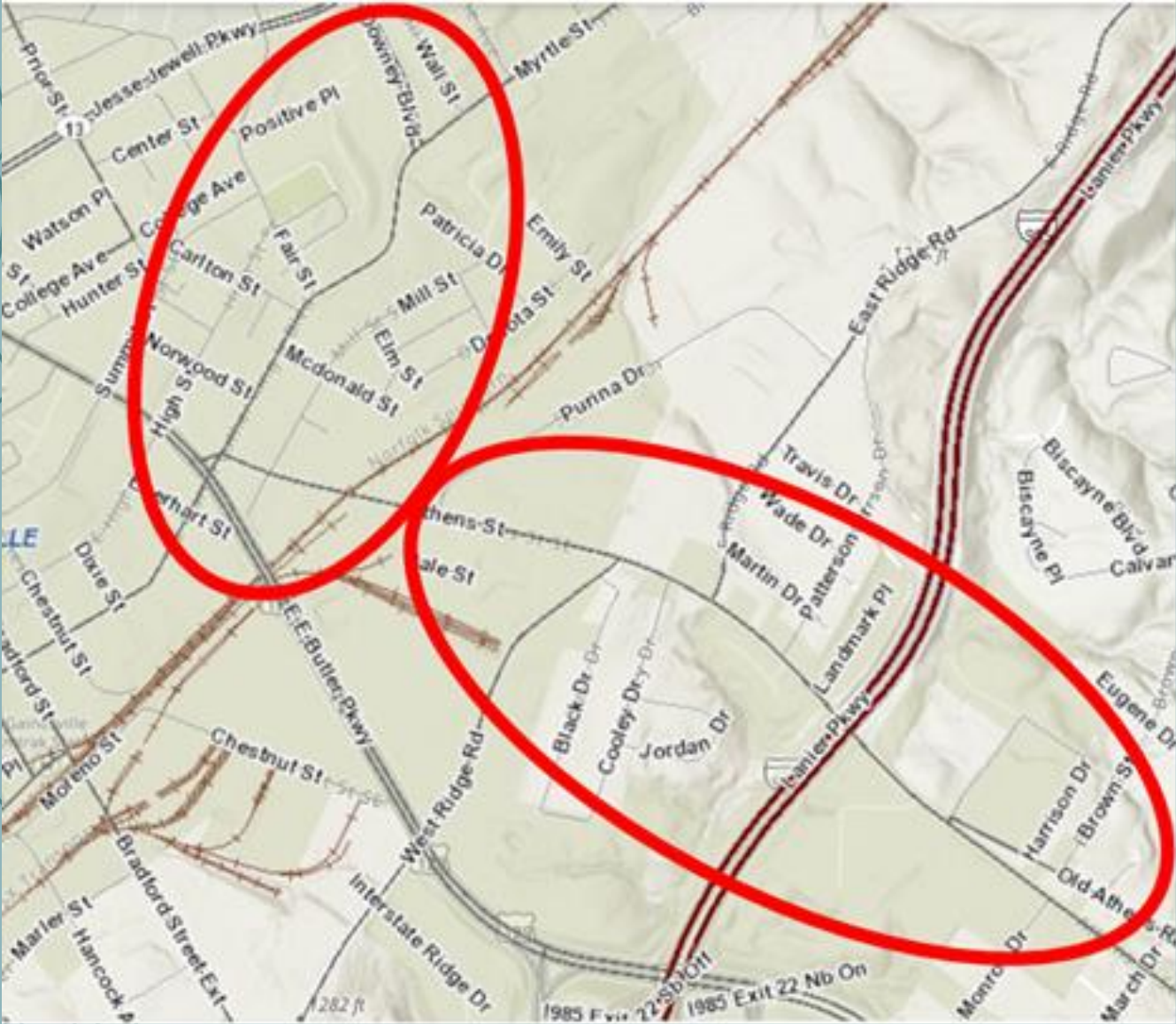

# Athens Street Study



Celebrate  
City's 200<sup>th</sup>  
birthday  
year-round

# Bring back Citizens Gov. Academy



# Updates to Municipal Courtroom & Council Meeting Room





Assist C&ED  
in promoting  
economic  
development



QUESTIONS?  
COMMENTS?  
CONCERNS?

**GAINESVILLE  
CITY COUNCIL  
RETREAT**

**2021-22 BUDGET PRIORITIES  
THE STATION – GAINESVILLE ADMINISTRATION BUILDING**

**Date Submitted:** 2/18/2021  
**Presenter:** Jeremy Perry  
**Item of Business:** • Financial Update  
**Meeting Date:** 2/19/2021

---

**Purpose of Request:**

**History/Background:**

**Facts & Issues for Consideration:**

**Department Recommendation:**

**Department Director:**

---

**If funding is involved, are funds approved within the current budget?**

**Amount Requested:**

**Source of Funds:**

**Finance Comments:**

---

**Administrative Comments:**

---

**ATTACHMENTS:**

Description	Type
<input type="checkbox"/> FY21-22 Financial Update Retreat Presentation	Powerpoint Presentation



# FINANCIAL SERVICES

## GAINESVILLE CITY COUNCIL RETREAT

2021-22 BUDGET PRIORITIES  
THE STATION – GAINESVILLE ADMINISTRATION BUILDING

# General Fund Property Tax Revenue

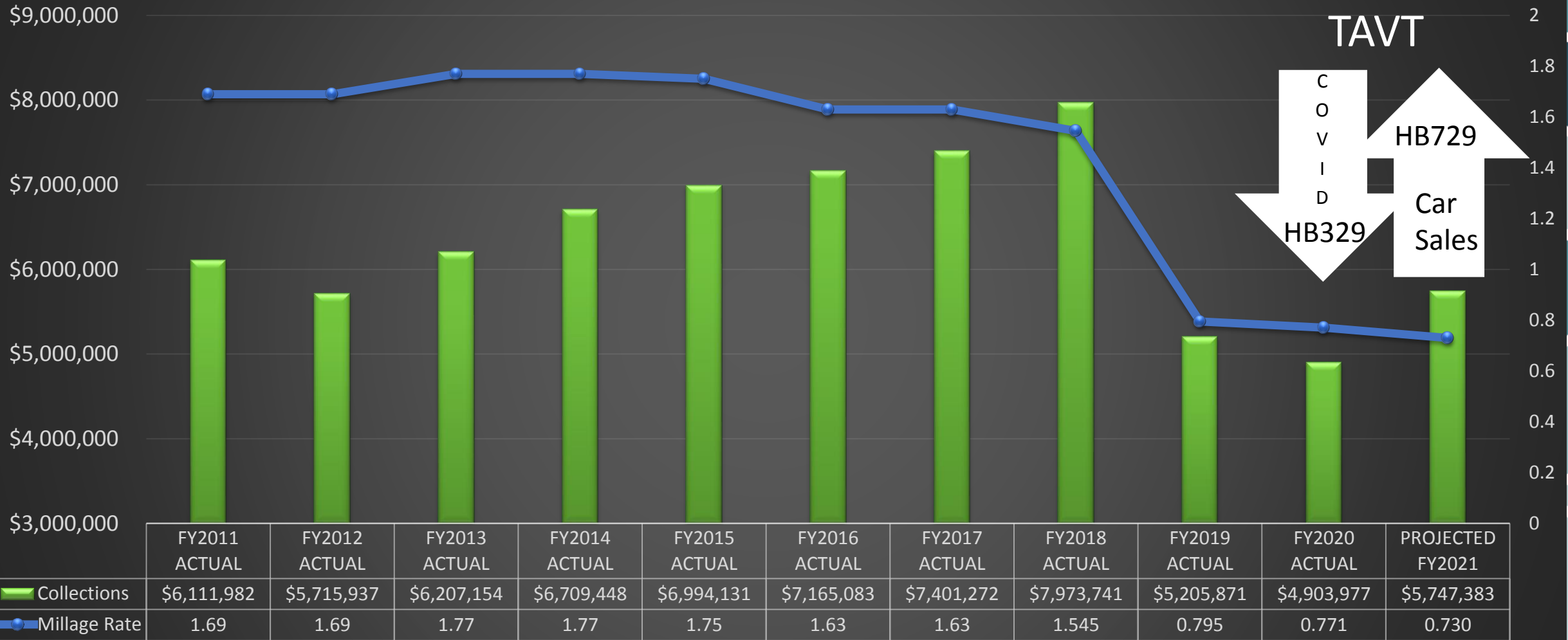

# FINANCIAL UPDATE

# Local Option Sales Tax Revenue

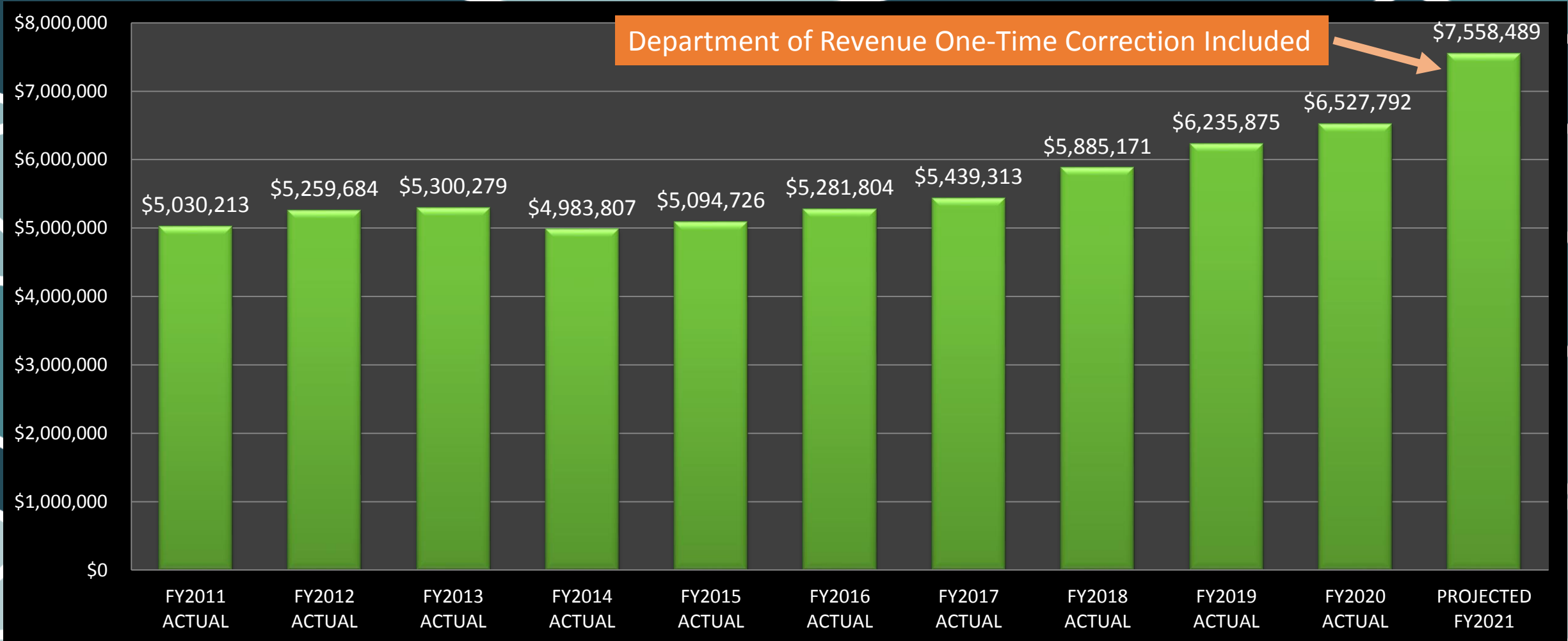

# FINANCIAL UPDATE

# Franchise Fee Revenue

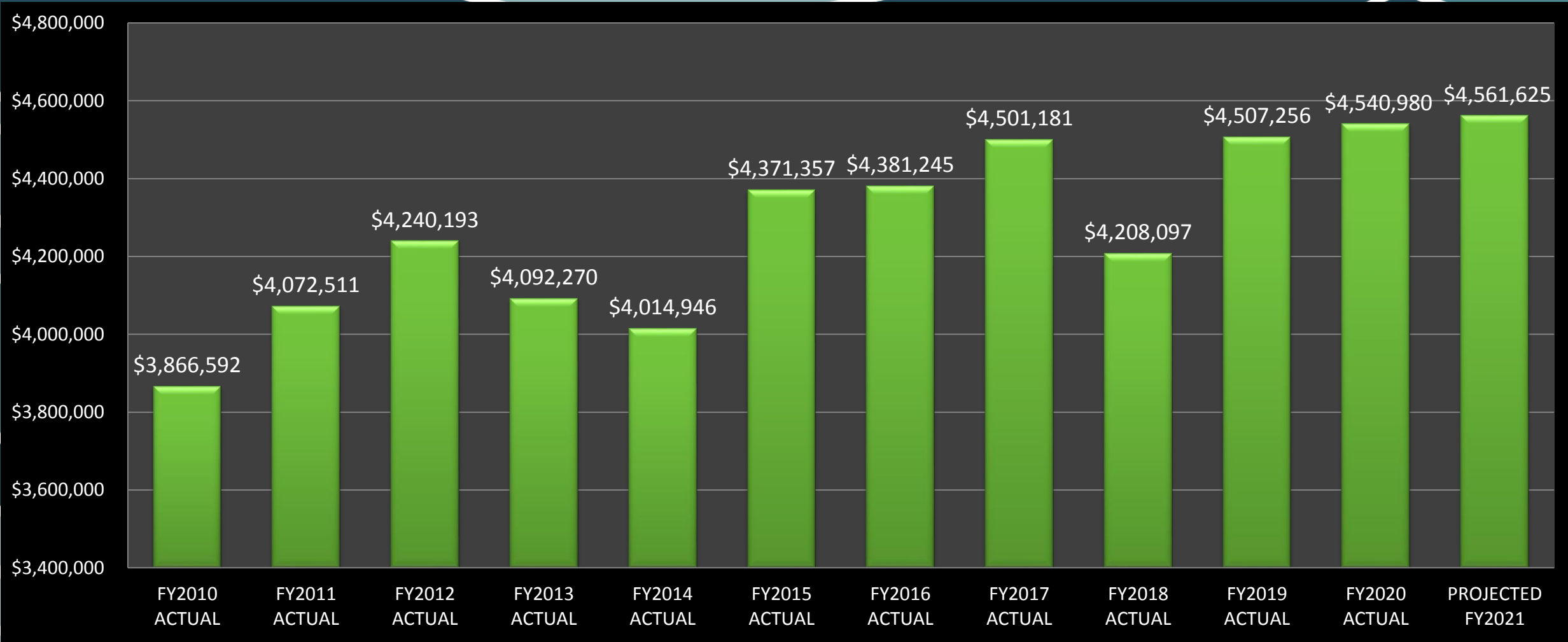

# FINANCIAL UPDATE

# Fines and Forfeiture Revenue

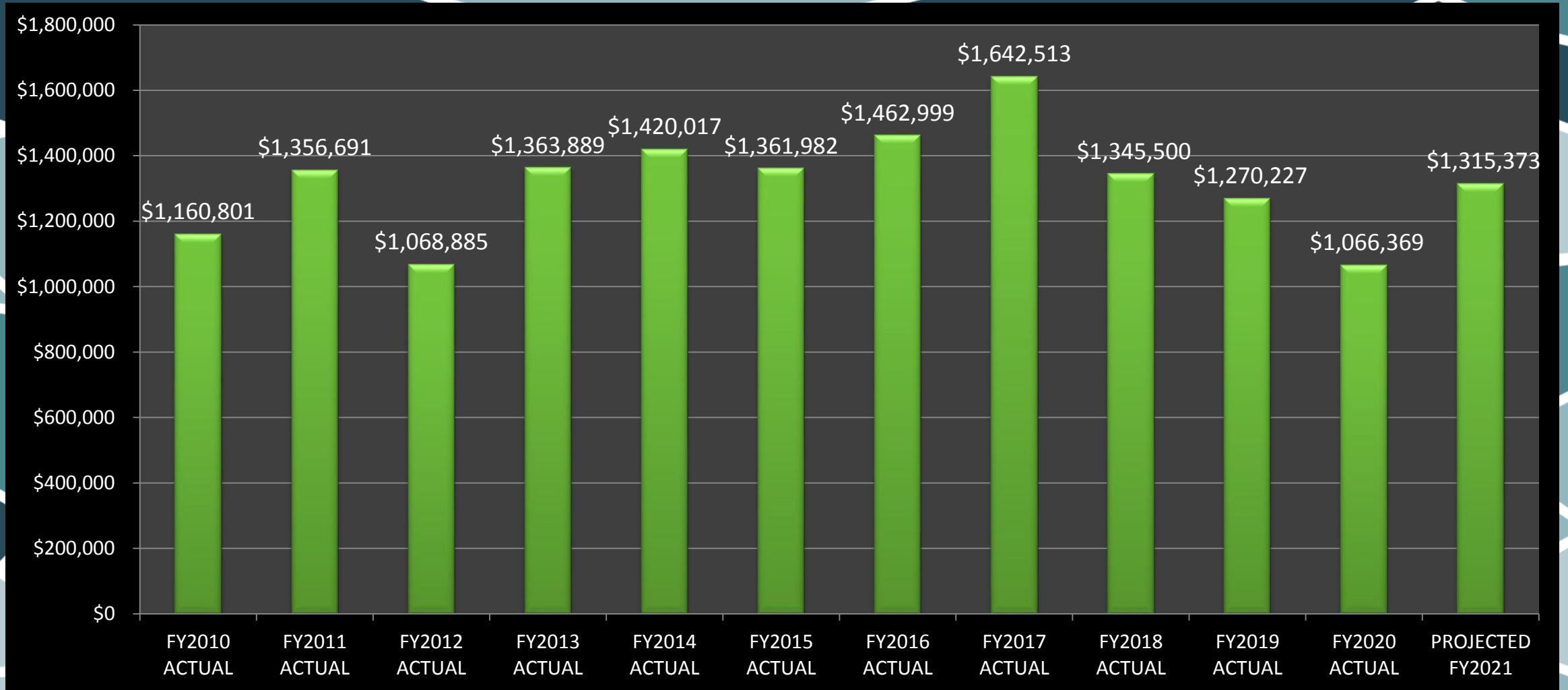

# FINANCIAL UPDATE

# Permits and Zoning Fee Revenue

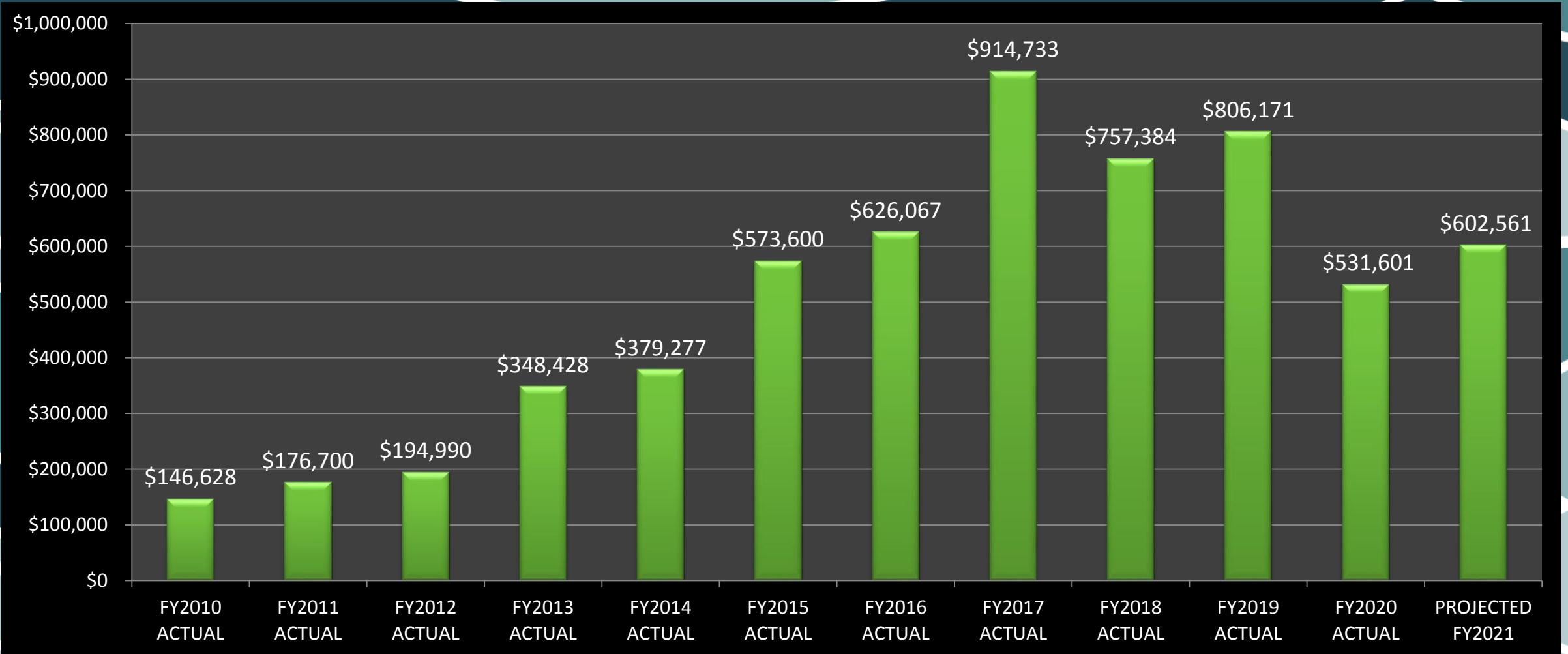

# FINANCIAL UPDATE

# Occupational Tax Revenue



## FINANCIAL UPDATE

# General Fund Operating Revenues

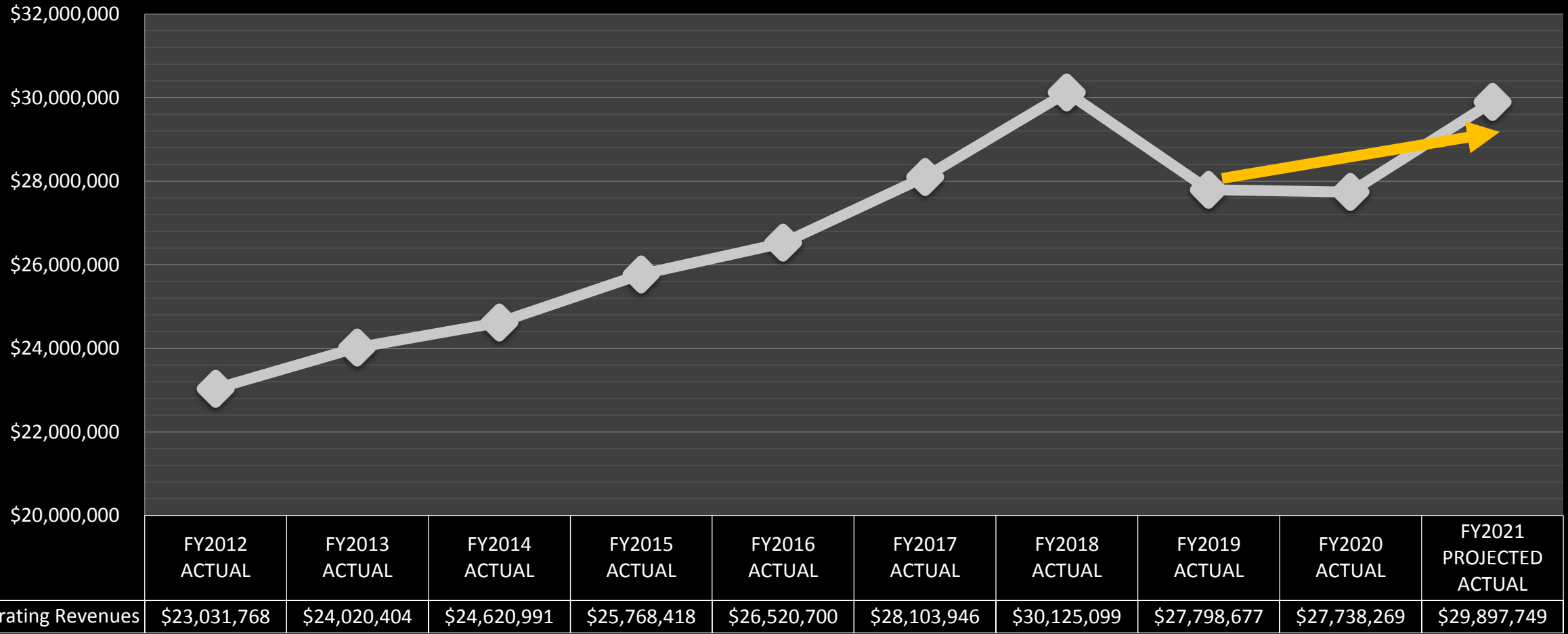

# FINANCIAL UPDATE

# General & Fire Fund – Fund Balance

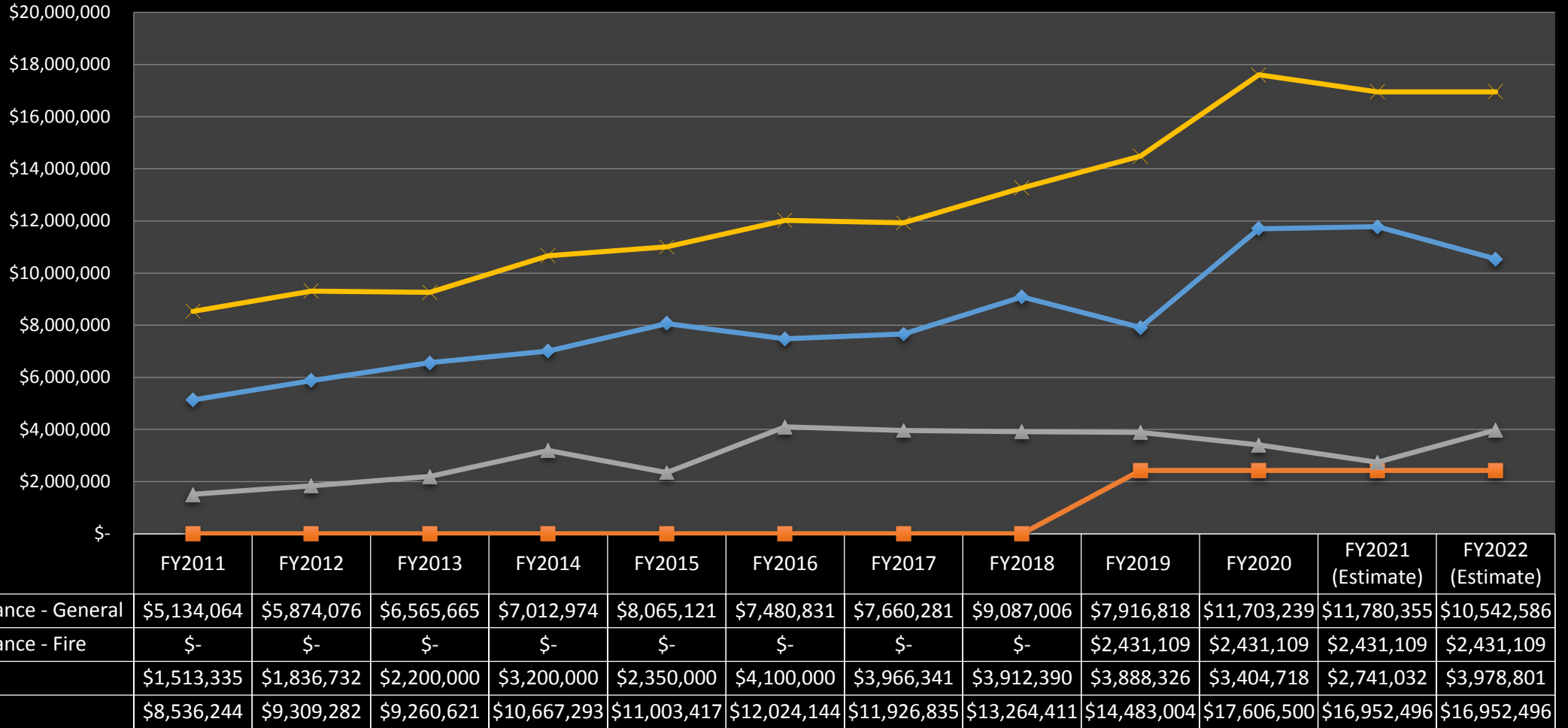

# FINANCIAL UPDATE

# General & Fire Fund – Fund Balance

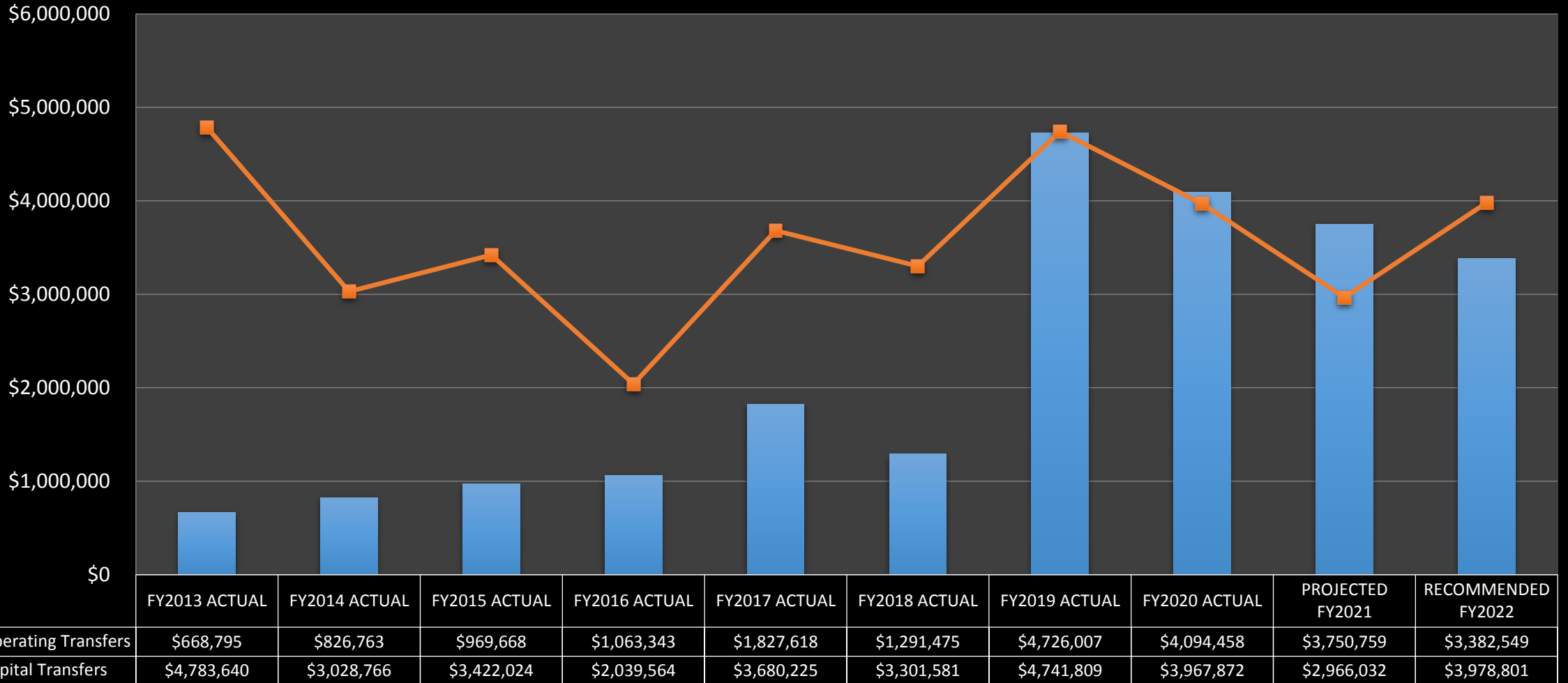

# FINANCIAL UPDATE



# ACCOMPLISHMENTS

Before  
we were



**hALL IN**

We were preparing and relocating our operations to:

- Dining rooms
- Kitchens
- Bedrooms
- Garages

To keep operations running.

# CURRENT DISCUSSION: ACCOMPLISHMENTS

Received annual awards for Budget, PAFR and CAFR (with no findings).

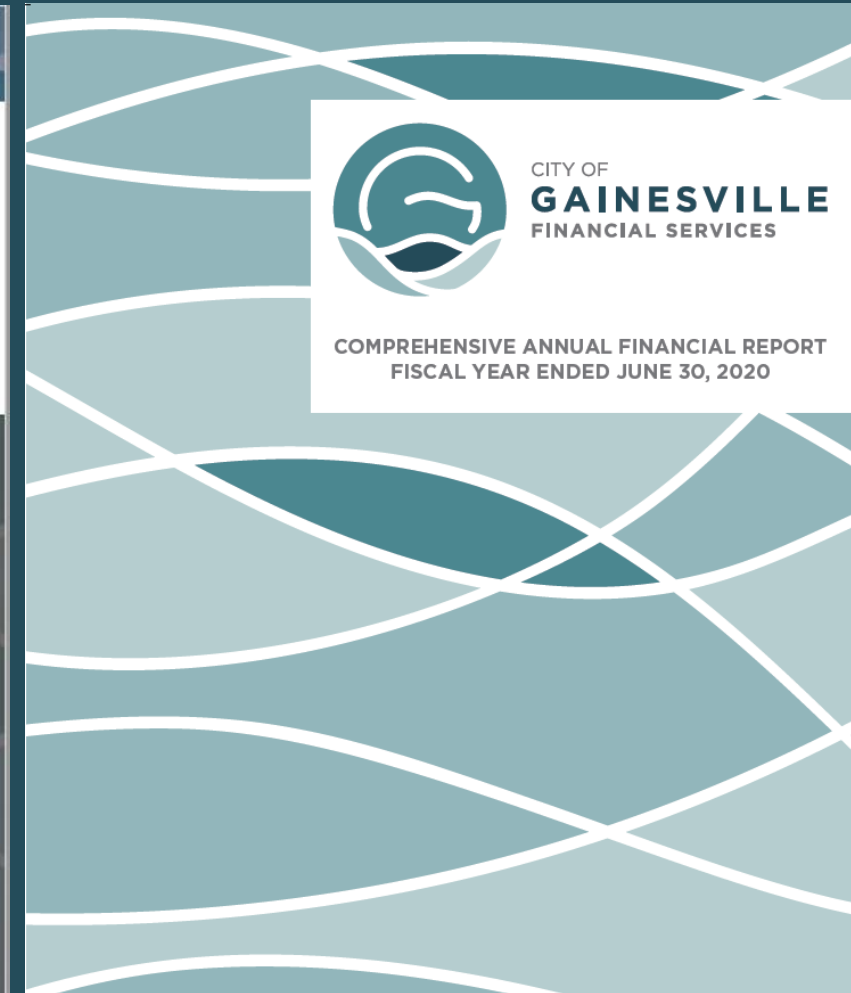
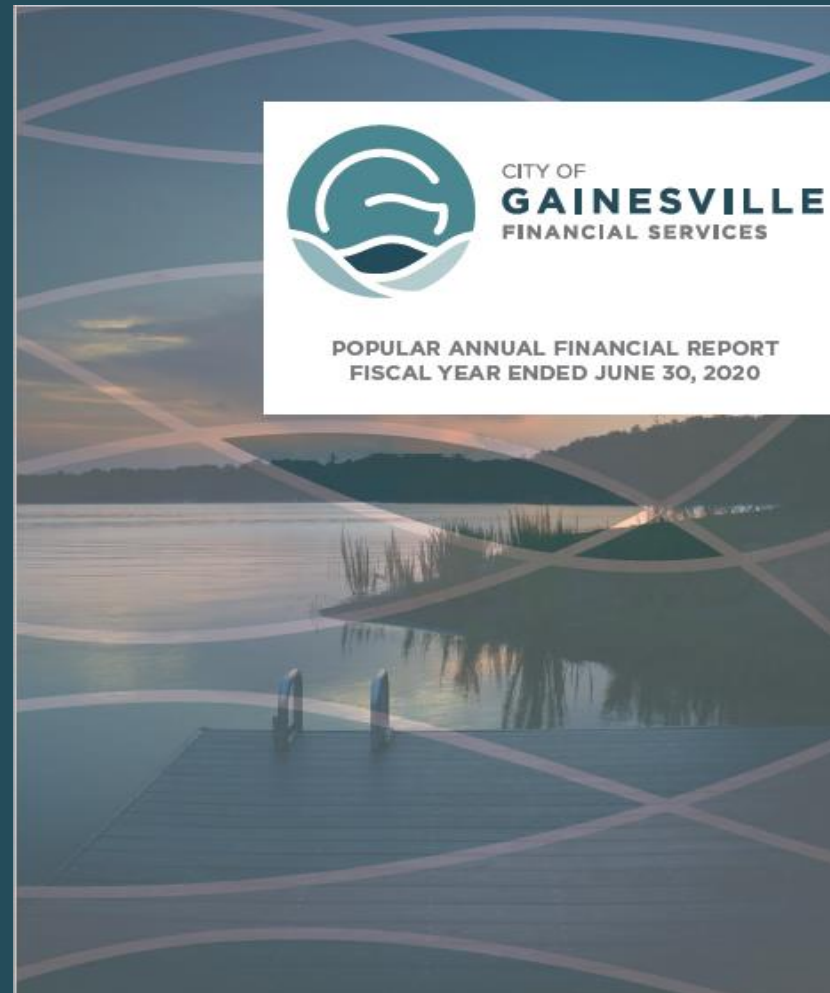
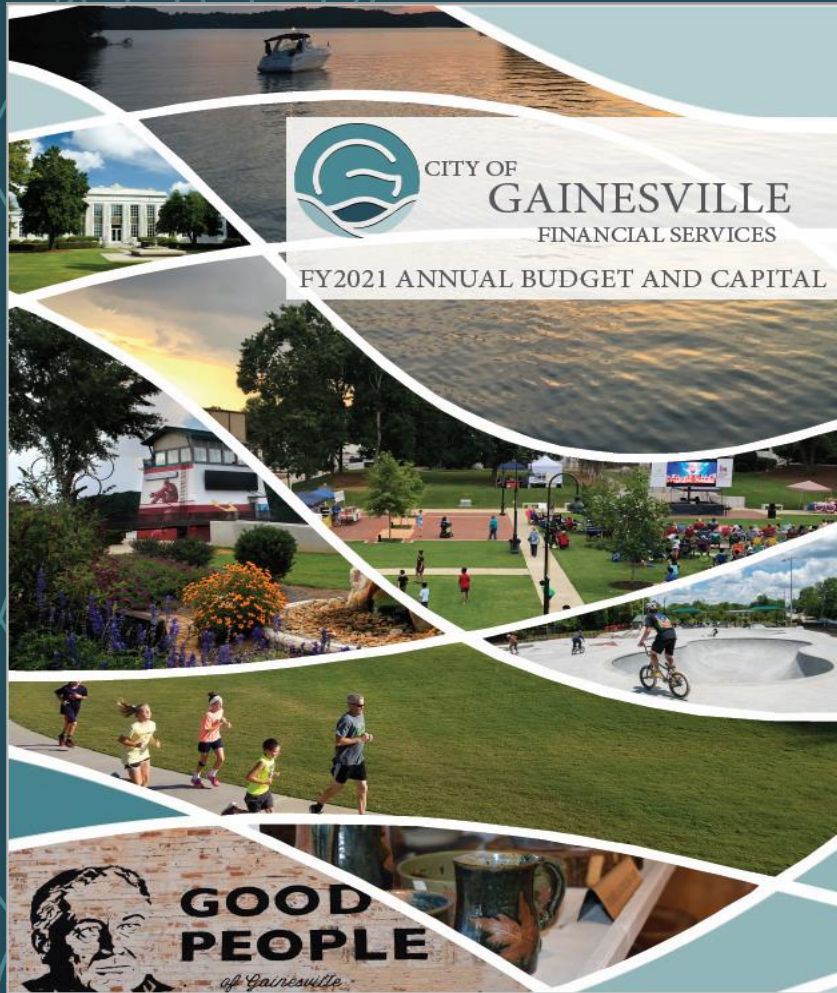

**ROLLING READING ROOM**  
Buses filled with books travel region to fill young minds.  
Our Region, 1C

**MILLIPEDE MIGRATION**  
Make sure to seal cracks as insects swarm area.  
LIFE, 1D

# The Times

FRIDAY JUNE 20, 2014

90 CENTS GAINESVILLE, GEORGIA

gainesvilletimes.com

## City of Gainesville Did It Again!!!

Another Year of Solid Financial Statements

BY JOSHUA SILBERT  
jsilbert@gainesvilletimes.com

The Association County Commission of Georgia and the Georgia Municipal Association have begun talks to determine whether the program of distributing local option millage can be improved and made more equitable.

Mill County and Gainesville officials have participated in these discussions, providing the ACCG and GMA with insight into how LOST revenue is distributed locally.

Every 10 years, following the last census, creation and other inter-negotiations about how revenue from the 1 percent sales tax will be split.

The last negotiation for Mill County and its cities wrapped up in October of last year.

Mill County wound up receiving about 74 percent of LOST revenues while Gainesville received about 17 percent. The rest was split between Flowery Branch, Oakwood, Champlin, Lake Park, Braselton, Buford and Gilwood.

The eight criteria that counties and cities use when negotiating with one another about how to divide up LOST revenue is vague, at best.

An ACCG report published in August 2013 speaks to this point.

"The negotiations will be complicated by the fact that no one distribution formula will result in a uniform distribution of revenues among all counties," the report states. "The debate will focus on the fairness of the LOST revenue distribution, but no objective standard exists to guide the process."

■ Please see TAX, 7A

**LOST REVENUE BREAKDOWN**

- Mill County 26.40%
- Champlin 6.40%
- Flowery Branch 7.92%
- Gainesville 17.20%
- Lake Park 11.7%
- Lake 1.34%
- Oakwood 2.04%
- Braselton 0.57%
- Buford 0.49%

## Gainesville – Great place to Live, Work, and Play

Afterwards are set to give opening statements Monday in Mill County Superior Court after receiving reports for the murder trial of Joseph Scott Williams.

Williams is accused in the June 2013 shooting death of 37-year-old Adrian Thompson inside Joppers Grocery & Market on U.S. 84 in Gainesville.

The trial comes a little more than one year after the encounter between the two men on June 3, 2013. Williams was accused hours later in a traffic stop after a lookout was hired by Gainesville police, who said the 37-year-old shot Thompson multiple times before fleeing down U.S. 84.

Williams faces charges of murder, felony murder, possession of a

For people every day without being seen," James Hunter said.

Ann Nixon, executive director of Habitat for Humanity of Mill County, said some donors donate a material acce-

After a hot, 14-hour weekend their home, James and Kyla Hunter are happy to build a better future for a neighbor.

## Net Position – Last 5 Fiscal Years

Fiscal Year	Net Investment in Capital Assets	Restricted Net Position	Unrestricted Net Position	Total Net Position	Revenues over Expenses
2016	\$ 393,150,494	\$ 75,191,482	\$ (5,256,152)	\$ 463,085,824	\$ 22,940,202
2017	408,287,950	85,063,287	4,497,891	497,849,128	26,822,761
2018	441,615,856	91,958,754	2,432,283	536,006,893	40,205,997
2019	460,292,603	95,871,221	17,887,327	574,051,151	38,044,258
2020	492,931,241	99,296,683	17,728,105	609,956,029	35,904,878

- 1 Increase in SPLOST revenues, increase in governmental charges for services, reduction of governmental expenditures, and an increase in Department of Water Resources revenue
- 2 Large capital contributions received in FY 2018
- 3 Large capital contributions received in FY 2019 - Mundy Mill subdivision roads and infrastructure

Notes: - GASB 68 for Pensions was implemented in FY 2015 resulting in a negative Unrestricted Net Position that continues into FY 2016

- In FY 2018, the implementation of GASB 75 for OPEB further reduced Unrestricted Net Position

- Changes in actuarial assumptions reduced the OPEB liability in FY 2019 which increased the unrestricted net position.





STATE OF GEORGIA  
OFFICE OF THE GOVERNOR  
ATLANTA 30334-0090

Brian P. Kemp  
GOVERNOR

June 29, 2020

Dear City and County Leaders:

These are indeed unprecedented times. Thank you for your continued hard work in protecting the health and safety of the citizens of this state. Responding to and mitigating the COVID-19 pandemic have required close collaboration between all levels of government, our healthcare system, and the many private companies that have dedicated time and resources to defeating the virus. As we continue our fight, we must also look towards recovery.

As you know, Congress passed the Coronavirus Aid, Relief, and Economic Security Act ("CARES" Act) on March 27, 2020 to provide vital resources to governments, businesses, and individuals in combating COVID-19. President Trump signed the Act into law, and his administration continues to provide guidance on the many federal funding streams included in the legislation.

Title V of the CARES Act created the Coronavirus Relief Fund ("CRF") to provide financial resources to state and local governments. The U.S. Treasury (Treasury) provided Georgia approximately \$4.1 billion for coronavirus-related expenses based on the funding formula provided in the CARES Act. Treasury provided that up to 45% of Georgia's funding could be transferred to local governments if the transfer qualifies as a necessary expenditure incurred due to the public health emergency.

The Governor's Office, in conjunction with several partners such as the Governor's Office of Planning and Budget and the State Accounting Office, will manage the disbursement process for the CRF. The plan for CRF allocations and disbursements is a phased, measured approach. It is critical that funding be released

13<sup>th</sup> City in the  
State to receive  
the total  
allocation of the

**CARES Act Funding**



# CHALLENGES + OPPORTUNITIES

# CURRENT DISCUSSION: CHALLENGES + OPPORTUNITIES

## Georgia Fund 1

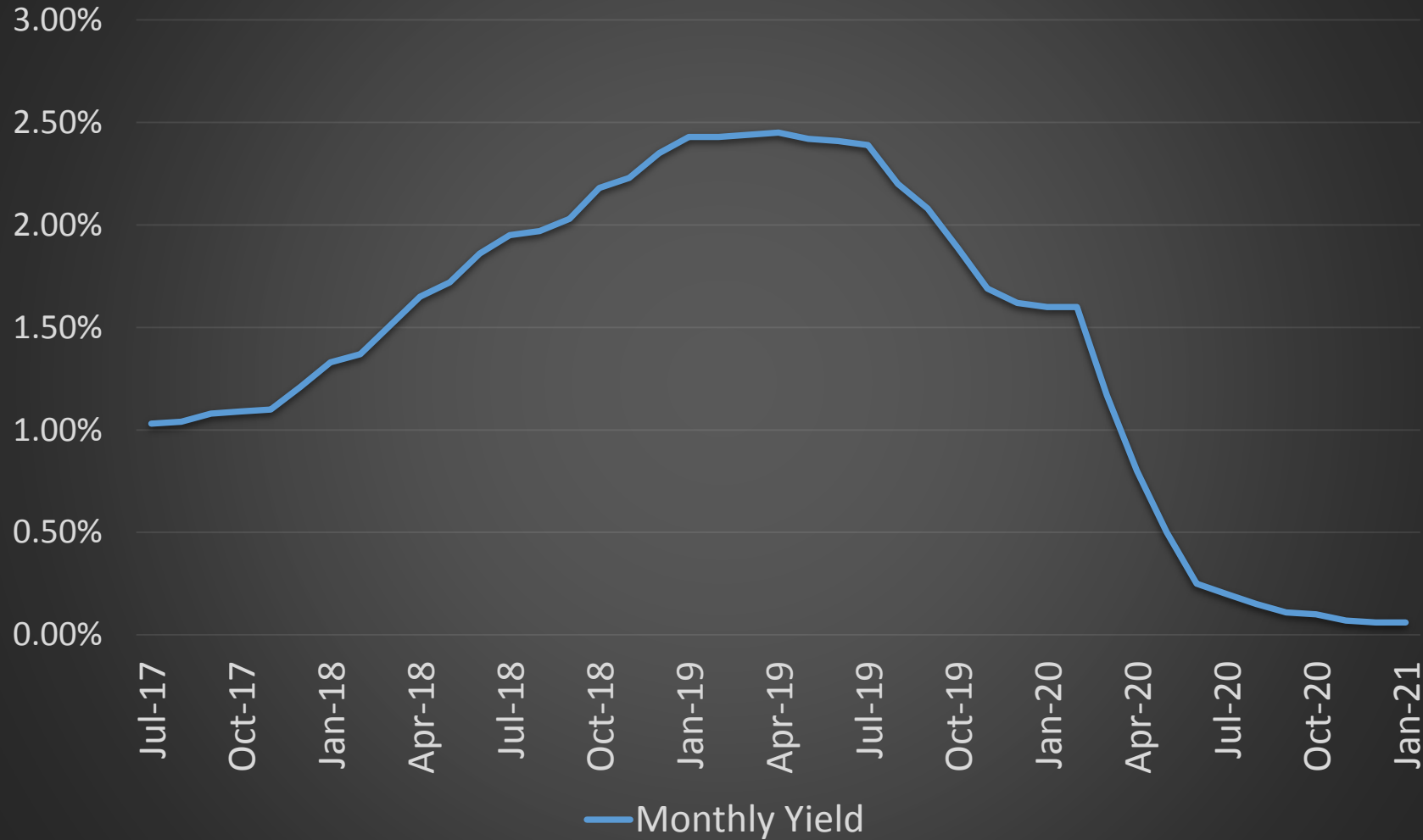

Maximize  
Investment  
Revenue  
during  
record  
lows

“With great funding comes  
great responsibility”

**5 Additional  
Grants/Funding  
totaling \$8.3M**

- Increase Tracking
- Financial Reporting
- Additional Auditing

# CURRENT DISCUSSION: CHALLENGES + OPPORTUNITIES



**BUDGET PRIORITY: INTERNAL OPERATIONS | STRATEGIC AREA: CITYWIDE**



TAKING

CHARGE

# INITIATIVES

The logo for GASB (Governmental Accounting Standards Board) features the letters 'G', 'A', 'S', and 'B' in a bold, dark blue, sans-serif font. The letter 'A' is stylized with three diagonal lines crossing through it from the bottom-left to the top-right.

**New Guidance on  
Statement No. 87**

Implement GASB  
Statement No. 87  
pertaining to Leases.

CURRENT DISCUSSION: INITIATIVES

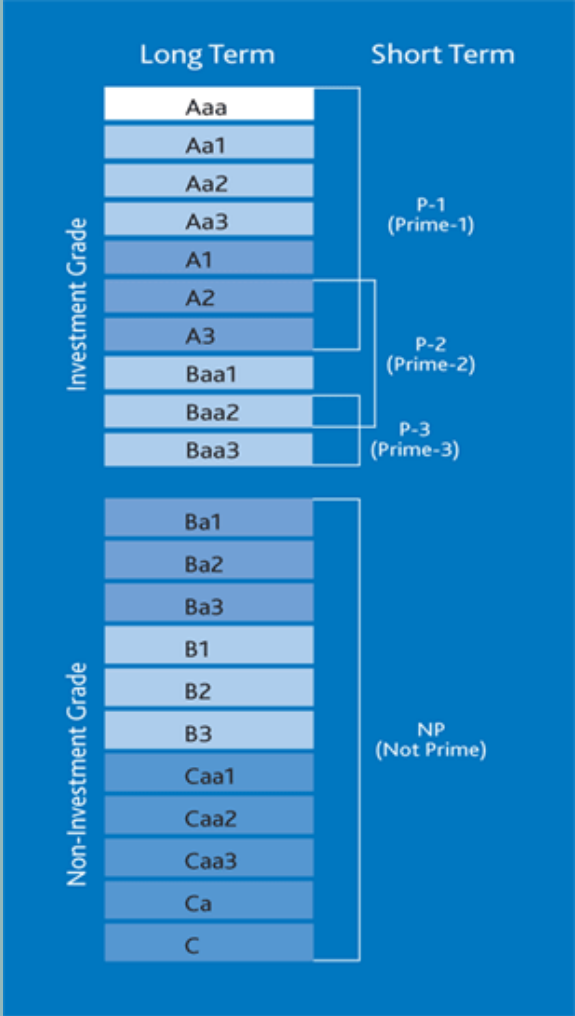

**Gainesville (City of) GA**  
 Moody's Org ID: 600024338 LEI: 5493006Y11XKB3GQIF20 6 Digit Cusip: 362874 Market Segment: U.S. Public Finance  
 Sector: MUNICIPALITY State: Georgia County: Hall County, GA

---

<b>SENIORMOST TAX BACKED RATING</b> Rating: <b>Aa2</b> Type: <b>LT SR GO UNDERLYING</b> Date: <b>31 Aug 2012</b>	<b>SENIORMOST REVENUE BACKED RATING</b> Rating: <b>Aa2</b> Type: <b>LT SR REV UNDERLYING</b> Date: <b>11 Nov 2014</b>	<b>OUTLOOK</b> <b>Stable</b> Date: <b>31 Aug 2012</b>
---	--	---

# CURRENT DISCUSSION: INITIATIVES



**Total Capital Requested**  
**\$35,166,247**

80 Capital Improvement Projects

Total Funding Requested by Department



- City Manager's Office
- Planning & Zoning
- Fire
- PW-Engineering
- PW-Street Maintenance
- CC Facility Operations
- Information Technology
- Police
- Financial Services
- PW-Traffic
- PW-Stormwater
- Medical Waste

Total Funding Requested by Source



- General Fund
- CVB
- Lease Proceeds/ Other ...
- Intergovernmental
- Airport Fund
- Water Resources
- SPLOST
- Fire Fund
- Solid Waste Fund

Budgeted and Historical 2021 Revenues by Source

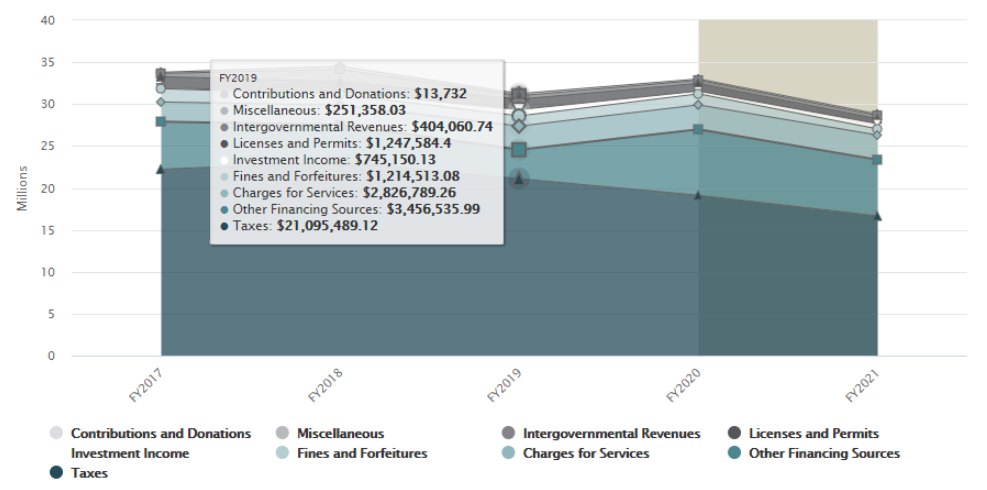

Grey background indicates budgeted figures.

Spreadsheet Breakdown >

**New Budget Interactive Software**



QUESTIONS?  
COMMENTS?  
CONCERNS?

**GAINESVILLE  
CITY COUNCIL  
RETREAT**

**2021-22 BUDGET PRIORITIES  
THE STATION – GAINESVILLE ADMINISTRATION BUILDING**

**Date Submitted:** 2/18/2021  
**Presenter:** Jerome Yarbrough  
**Item of Business:** • Fire  
**Meeting Date:** 2/19/2021

---

**Purpose of Request:**

**History/Background:**

**Facts & Issues for Consideration:**

**Department Recommendation:**

**Department Director:**

---

**If funding is involved, are funds approved within the current budget?**

**Amount Requested:**

**Source of Funds:**

**Finance Comments:**

---

**Administrative Comments:**

---

**ATTACHMENTS:**

Description	Type
<input type="checkbox"/> FY21-22 Fire Retreat Presentation	Powerpoint Presentation

# FIRE DEPARTMENT



## GAINESVILLE CITY COUNCIL RETREAT

FY22 BUDGET PRIORITIES  
THE STATION – GAINESVILLE ADMINISTRATION BUILDING



# ACCOMPLISHMENTS

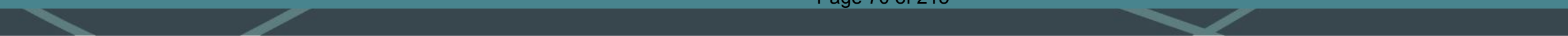



# Fire Station # 2

## CURRENT DISCUSSION: ACCOMPLISHMENTS



## Aerial Improvements

**BUDGET PRIORITY: INTERNAL OPERATIONS | STRATEGIC AREA: CITYWIDE**

# Preemption Intersections





# CHALLENGES + OPPORTUNITIES

# Total Call Volume Since 2009 Increase

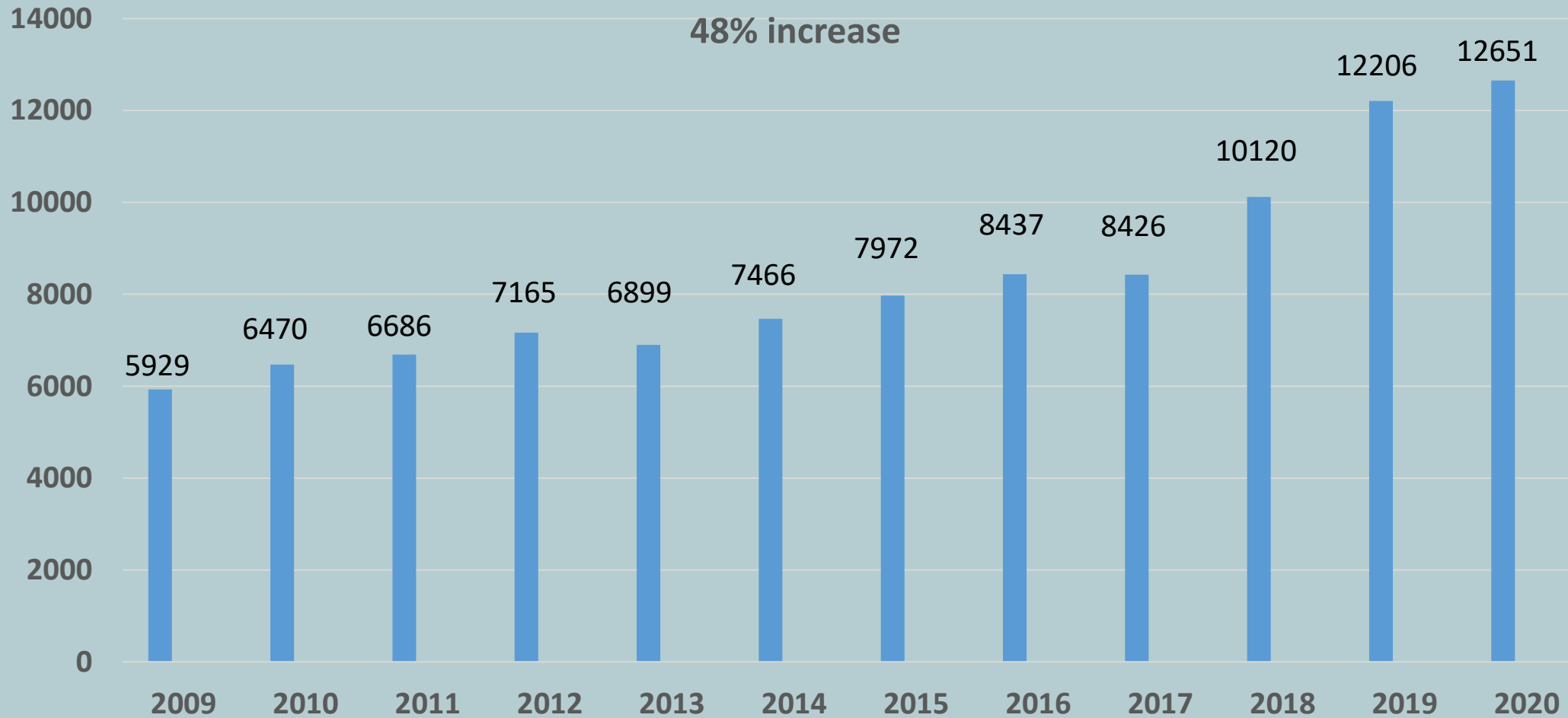

# Traffic



# Growth



# Growth



Average Response Time (Min:Sec) (Emergency)

2016	4:51
2017	4:43
2018	5:26
2019	4:46
2020	4:55
GOAL	5:00

**Growth**

Technology  
Communication  
Fiber Optic  
Cyber Awareness

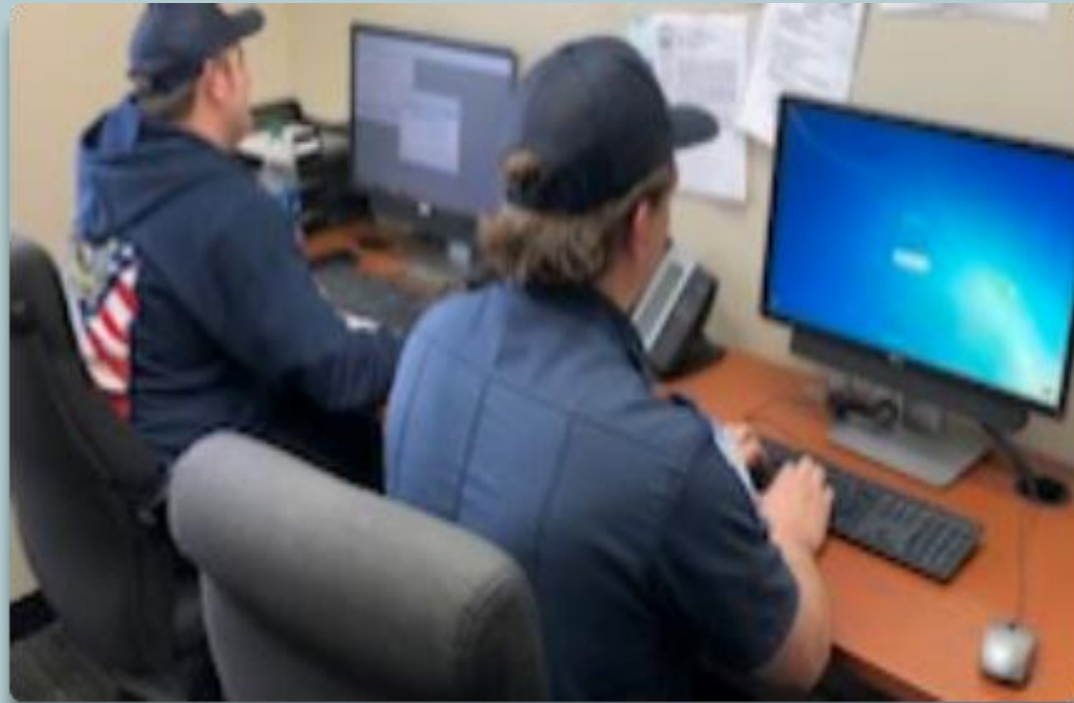



# INITIATIVES

CURRENT DISCUSSION: INITIATIVES

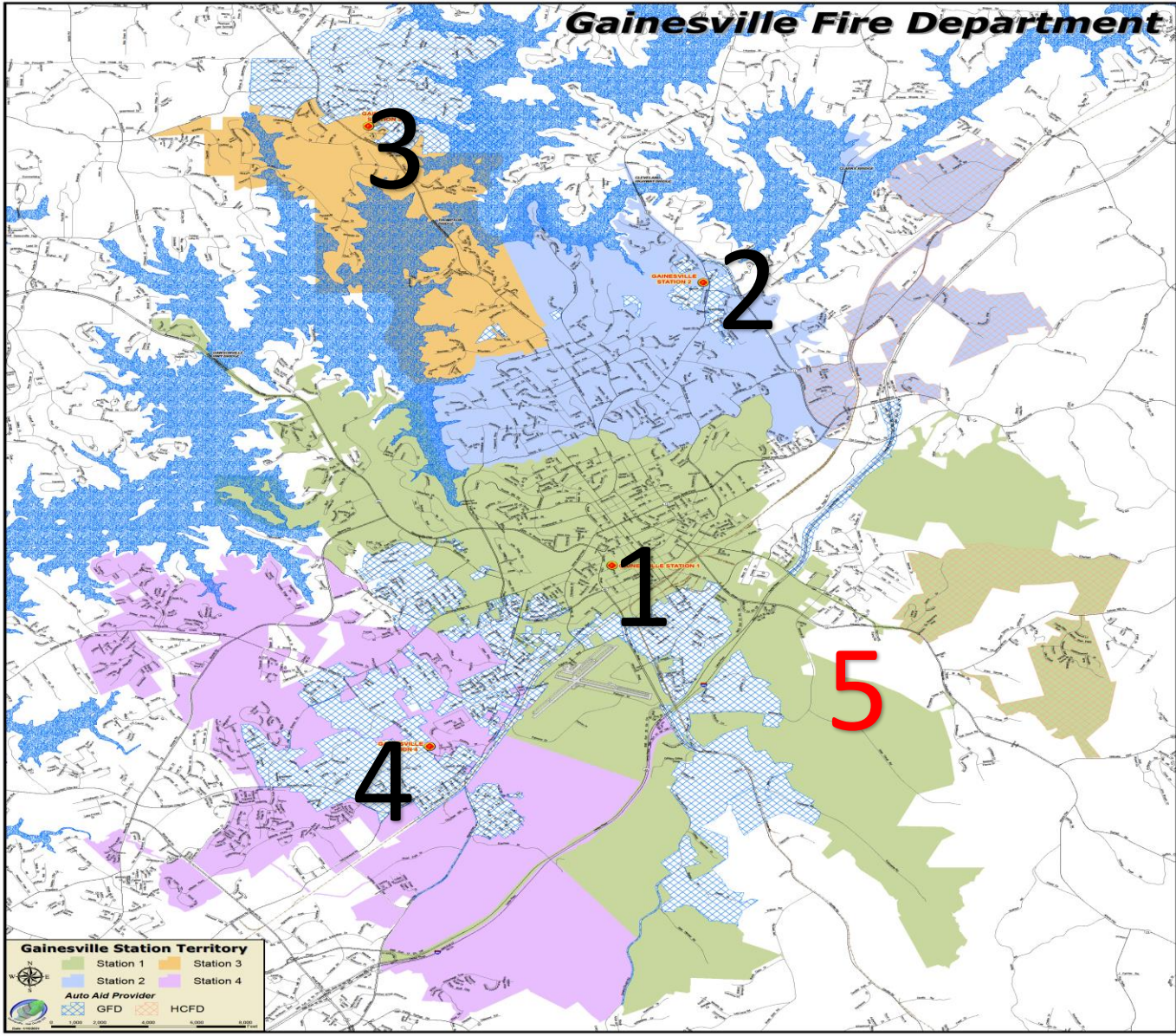

Fire  
Station  
Locations

CURRENT DISCUSSION: INITIATIVES

Fleet  
Services

Certified  
Technician



**CURRENT DISCUSSION: INITIATIVES**



Personnel

Competitive Salaries

**BUDGET PRIORITY: INTERNAL OPERATIONS | STRATEGIC AREA: CITYWIDE**

## CURRENT DISCUSSION: INITIATIVES



Fire & Rescue

Water Safety

# Gainesville/Hall County Joint Training Center Renovations / Relocation 2000 - 2021



# QUESTIONS?

**Jerome Yarbrough**

[jyarbrough@gainesvillega.gov](mailto:jyarbrough@gainesvillega.gov)

770-534-3612

[www.gainesvillega.gov](http://www.gainesvillega.gov)

## GAINESVILLE CITY COUNCIL RETREAT

**FY22 BUDGET PRIORITIES**  
Gainesville Fire Department

**Date Submitted:** 2/18/2021  
**Presenter:** Rodger Hogan  
**Item of Business:** • Golf  
**Meeting Date:** 2/19/2021

---

**Purpose of Request:**

**History/Background:**

**Facts & Issues for Consideration:**

**Department Recommendation:**

**Department Director:**

---

**If funding is involved, are funds approved within the current budget?**

**Amount Requested:**

**Source of Funds:**

**Finance Comments:**

---

**Administrative Comments:**

---

**ATTACHMENTS:**

Description	Type
<input type="checkbox"/> FY21-22 CGC Retreat Presentation	Powerpoint Presentation



# CHATTAHOOCHEE GOLF COURSE

## GAINESVILLE CITY COUNCIL RETREAT

2021-22 BUDGET PRIORITIES  
THE STATION – GAINESVILLE ADMINISTRATION BUILDING



# ACCOMPLISHMENTS

## CURRENT DISCUSSION: ACCOMPLISHMENTS



Teaching Center Before Painting

## CURRENT DISCUSSION: ACCOMPLISHMENTS



Teaching Center - After

# CURRENT DISCUSSION: ACCOMPLISHMENTS

## Pro Shop



Before



After

# CURRENT DISCUSSION: ACCOMPLISHMENTS

## Pro Shop



Before



After

# CURRENT DISCUSSION: ACCOMPLISHMENTS



Bill Bergin – Feasibility Study

# CURRENT DISCUSSION: ACCOMPLISHMENTS

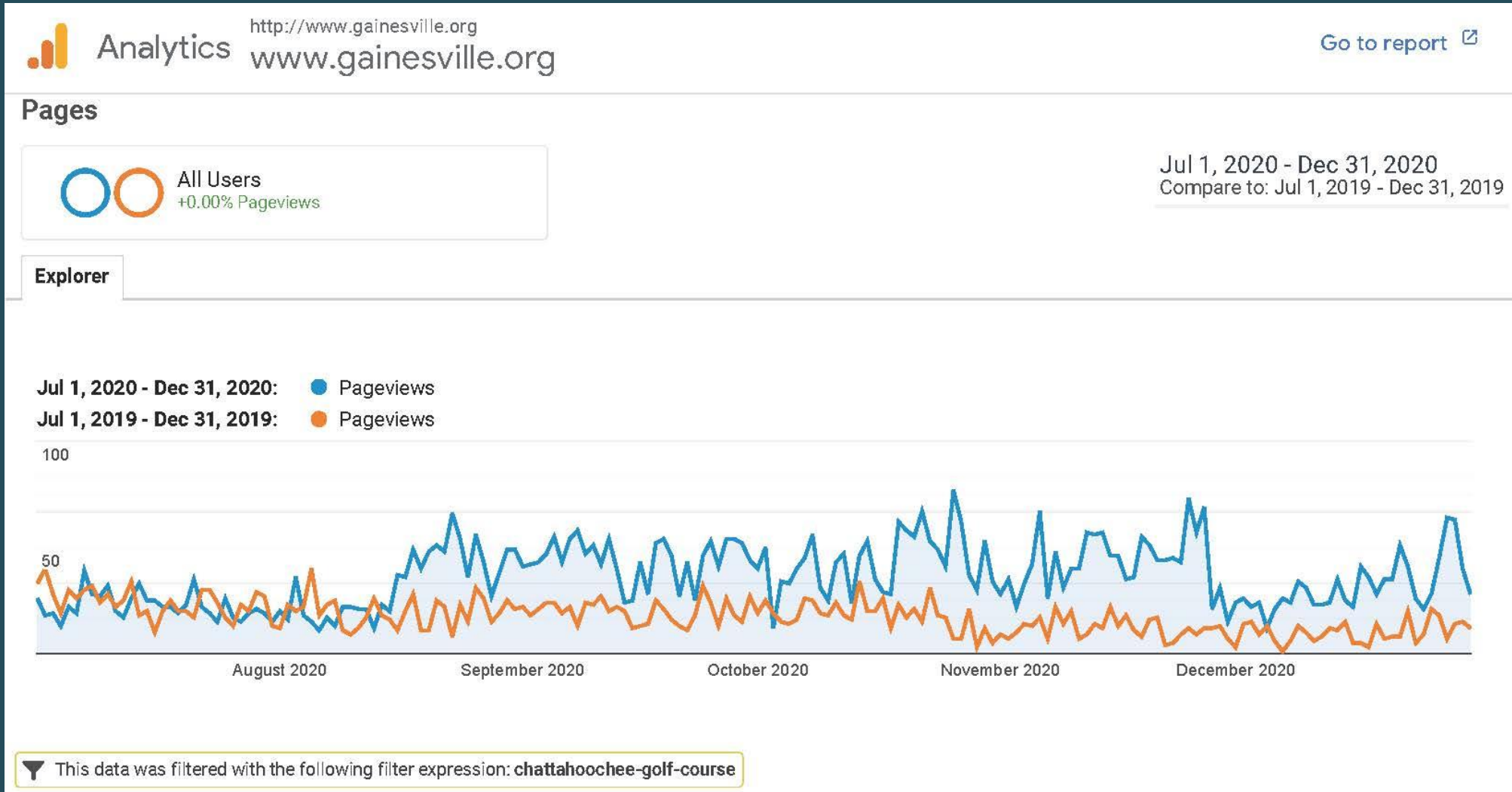

## Website Hits

# CURRENT DISCUSSION: ACCOMPLISHMENTS

**1 33**

**2 32**

**3 35**

**4 42**

**5 40**

**6 36**

**7 34**

**8 33**

**9 35**

**USGA RULES GOVERN PLAY**  
All players are required to register before playing.

All players must replace divots, smooth sand bunkers, fix ball marks on greens and observe golf etiquette.

**LOCAL RULES**

Relief Areas: Surfaced Drainage Ditches, Cart Paths, Roads, Shelters, Staked Trees.

Boundary Fences: No Relief

Round Fairway Yardage Markers:  
Red: 100 Yards  
White: 150 Yards  
Blue: 200 Yards

All Yardage Measured to Center of Green.  
**4 HOURS PLAY A MUST**

**Chattahoochee Golf Club**  
301 Tommy Aaron Drive  
Gainesville, GA 30506  
770-532-0066 | Grill: 770-532-1173  
Course Designer: Robert Trent Jones, Sr. (1960)  
Re-Design (2006): Kevin H. Hargrave

INSURANCE - REAL ESTATE  
**THE POWER TO PERFORM**  
North Georgia's Largest Insurance Agency  
Auto □ Home □ Business □ Health □ Life  
www.nortoninsurance.com | www.gonorton.com  
770-532-0022

New  
Scorecard  
Design

Hole	1	2	3	4	5	6	7	8	9	Out	10	11	12	13	14	15	16	17	18	In	Tot	Hcp	Net
Black 73.9/131	387	404	158	392	221	602	455	526	453	3598	353	394	228	533	379	591	409	210	420	3517	7115		
Players 72.7/128	387	404	158	365	198	575	418	526	405	3436	353	394	206	533	354	564	382	192	420	3398	6834		
Blue 71.6/126	360	379	139	365	198	575	418	496	405	3335	329	372	206	484	354	564	382	192	386	3269	6604		
Tournament 70.6/124	360	379	139	365	171	539	398	496	405	3252	329	372	171	484	354	542	356	165	386	3159	6411		
White 69.4/122	340	358	115	324	171	539	398	471	341	3057	308	362	171	449	334	542	356	165	364	3051	6108		
HDCCP	13	9	17	11	15	3	1	5	7		14	10	16	6	12	2	4	18	8				
Par	4	4	3	4	3	5	4	5	4	36	4	4	3	5	4	5	4	3	4	36	72		
Gold 66.4/115	317	304	105	316	128	465	348	463	331	2777	303	296	146	422	283	459	297	159	328	2693	5470		
Green 63.4/104	313	257	87	277	122	391	290	407	308	2452	228	290	117	396	277	403	293	108	285	2397	4849		
Red 67.8/114	313	225	87	277	122	391	290	407	308	2420	228	290	117	396	277	403	293	108	285	2397	4817		
Ladies' HDCCP	11	13	17	7	15	1	5	3	9		14	10	18	2	12	4	8	16	6				
Scorer:											Attest:											Date:	

**10 27**

**11 35**

**12 35**

**13 31**

**14 33**

**15 31**

**16 33**

**17 33**

**18 37**



# CHALLENGES + OPPORTUNITIES

## CURRENT DISCUSSION: CHALLENGES + OPPORTUNITIES

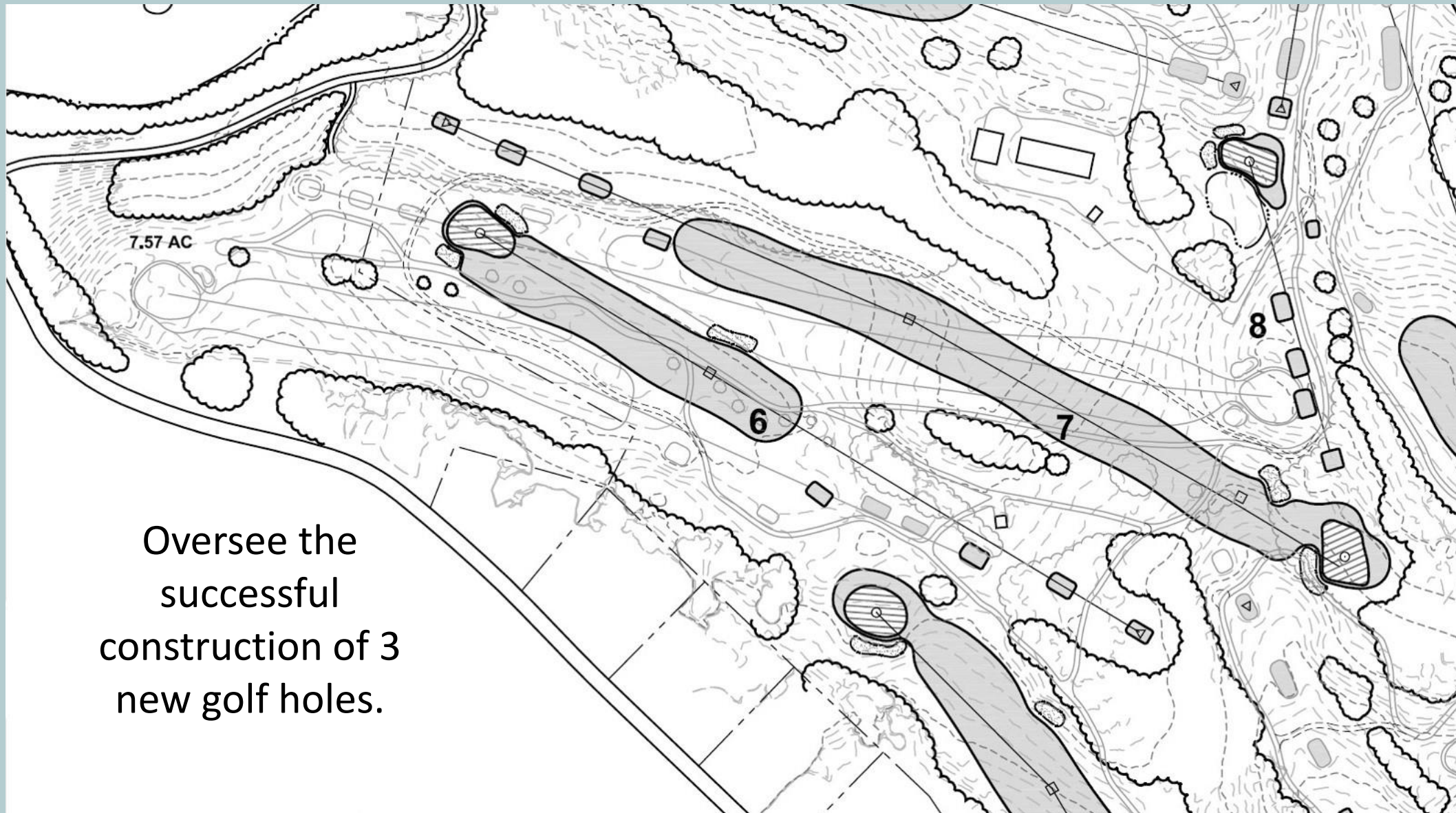

Oversee the successful construction of 3 new golf holes.

Restore the original  
Robert Trent Jones Sr.  
par 3 Signature Hole



**#8** Par 3 Black 165 Blue 135 White 130 Gold 110 Green 85 Red 80

# CURRENT DISCUSSION: CHALLENGES + OPPORTUNITIES

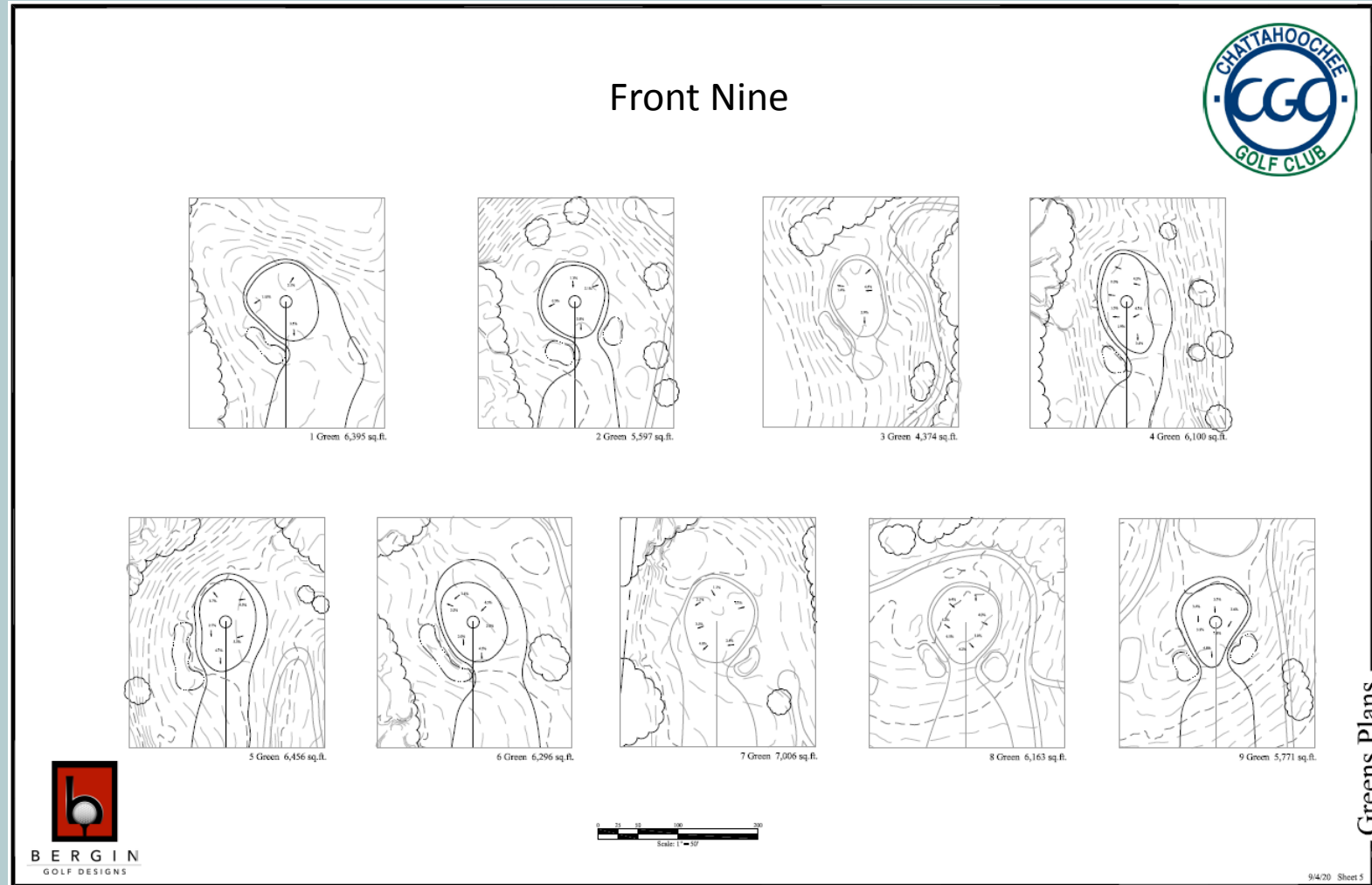

Oversee the re-contouring of existing greens, converting from Bentgrass to Tifeagle Bermuda.

# CURRENT DISCUSSION: CHALLENGES + OPPORTUNITIES

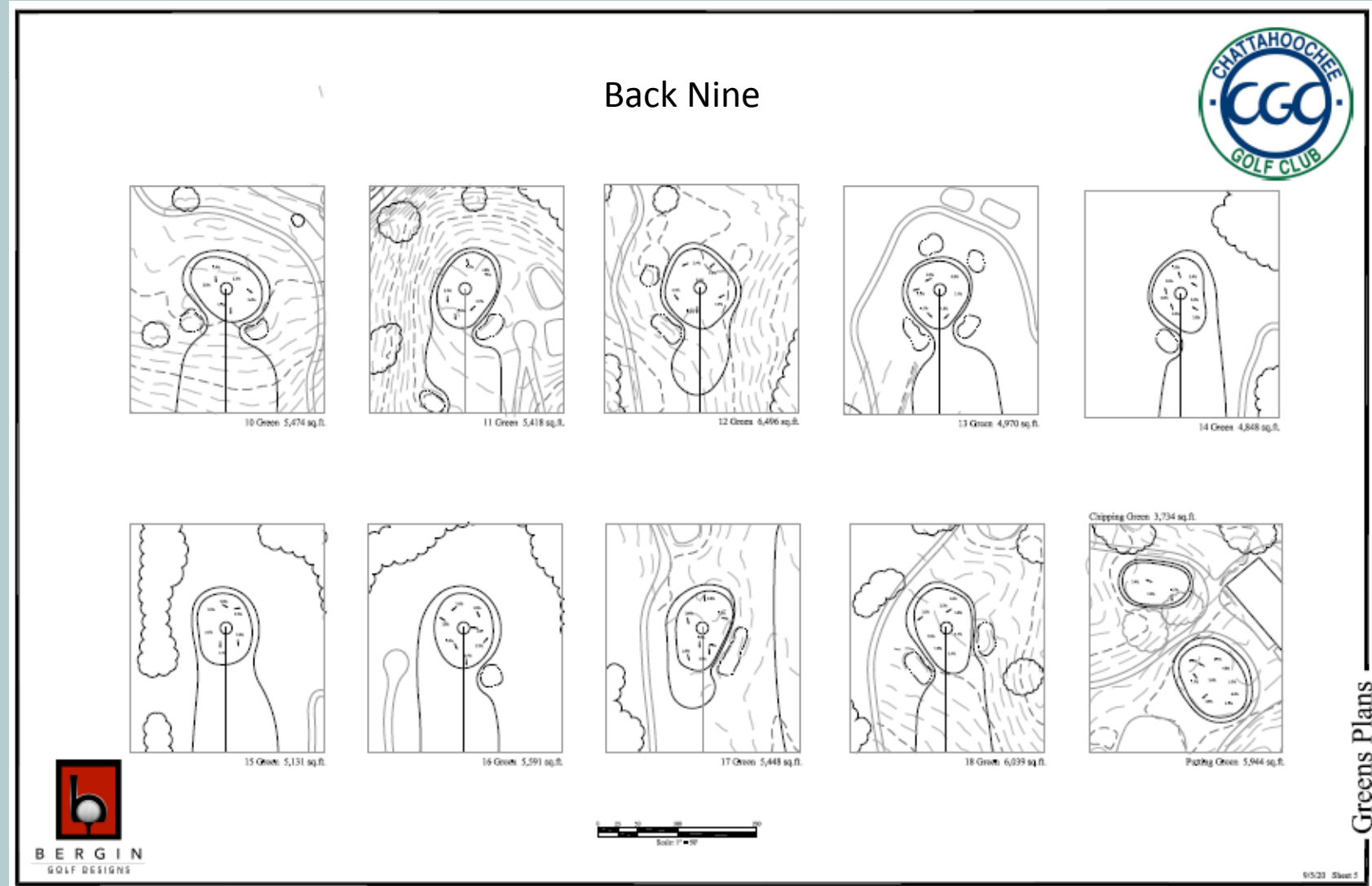



# INITIATIVES

CURRENT DISCUSSION: **INITIATIVES**

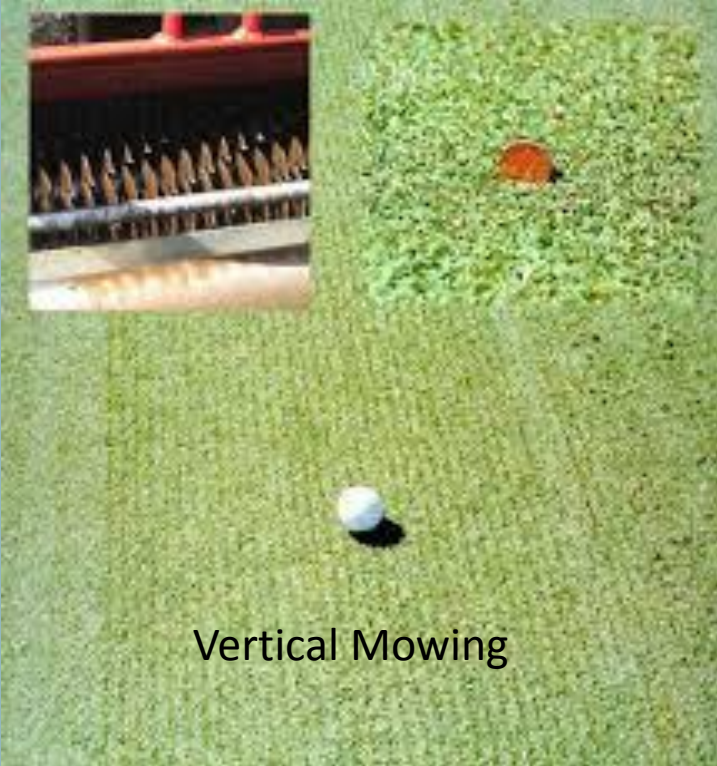

Continuing Education for maintaining TifEagle Bermuda putting greens.

CURRENT DISCUSSION: **INITIATIVES**

Renew 5 year  
tee marker  
contracts with  
existing advertisers  
and sell the  
remaining available  
advertising spots to  
new businesses.



## CURRENT DISCUSSION: INITIATIVES

### OTHER INITIATIVES

- Create a new scorecard to reflect renovation changes to the golf course.
- Take photos of the construction progress and send them out on social media each week.
- Negotiate a new lease to replace our 4+ year old golf cart fleet before re-opening.
- Schedule and coordinate with the USGA rating team to re-rate the golf course prior to opening.
- Reverse the nines, changing #10 to #1 making the back side the more difficult and challenging finish.



QUESTIONS?  
COMMENTS?  
CONCERNS?

**GAINESVILLE  
CITY COUNCIL  
RETREAT**

**2021-22 BUDGET PRIORITIES  
THE STATION – GAINESVILLE ADMINISTRATION BUILDING**

**Date Submitted:** 2/18/2021  
**Presenter:** Janeann Allison  
**Item of Business:** • Administrative Services  
**Meeting Date:** 2/19/2021

---

**Purpose of Request:**

**History/Background:**

**Facts & Issues for Consideration:**

**Department Recommendation:**

**Department Director:**

---

**If funding is involved, are funds approved within the current budget?**

**Amount Requested:**

**Source of Funds:**

**Finance Comments:**

---

**Administrative Comments:**

---

**ATTACHMENTS:**

Description	Type
<input type="checkbox"/> FY21-22 Administrative Services Retreat Presentation	Powerpoint Presentation

# Administrative Services



## GAINESVILLE CITY COUNCIL RETREAT

**2021-22 BUDGET PRIORITIES  
THE STATION – GAINESVILLE ADMINISTRATION BUILDING**



# ACCOMPLISHMENTS

Navigating the  
law, adapting  
to, and  
supporting  
employees

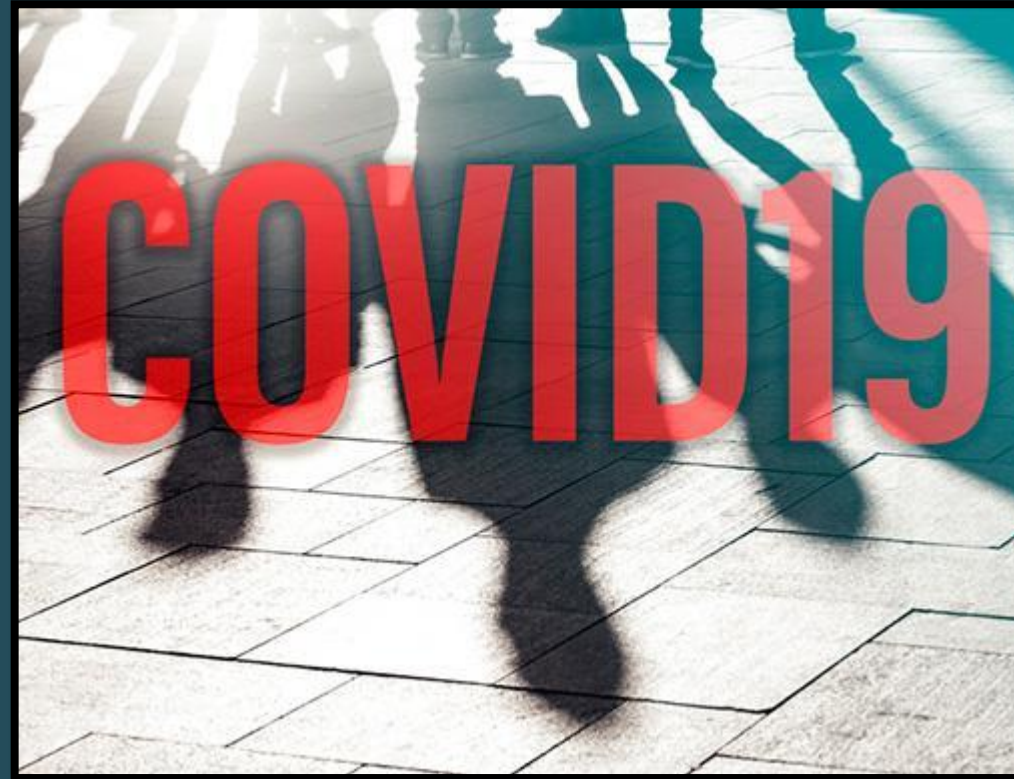

Assisted with  
a very  
successful  
employee  
event

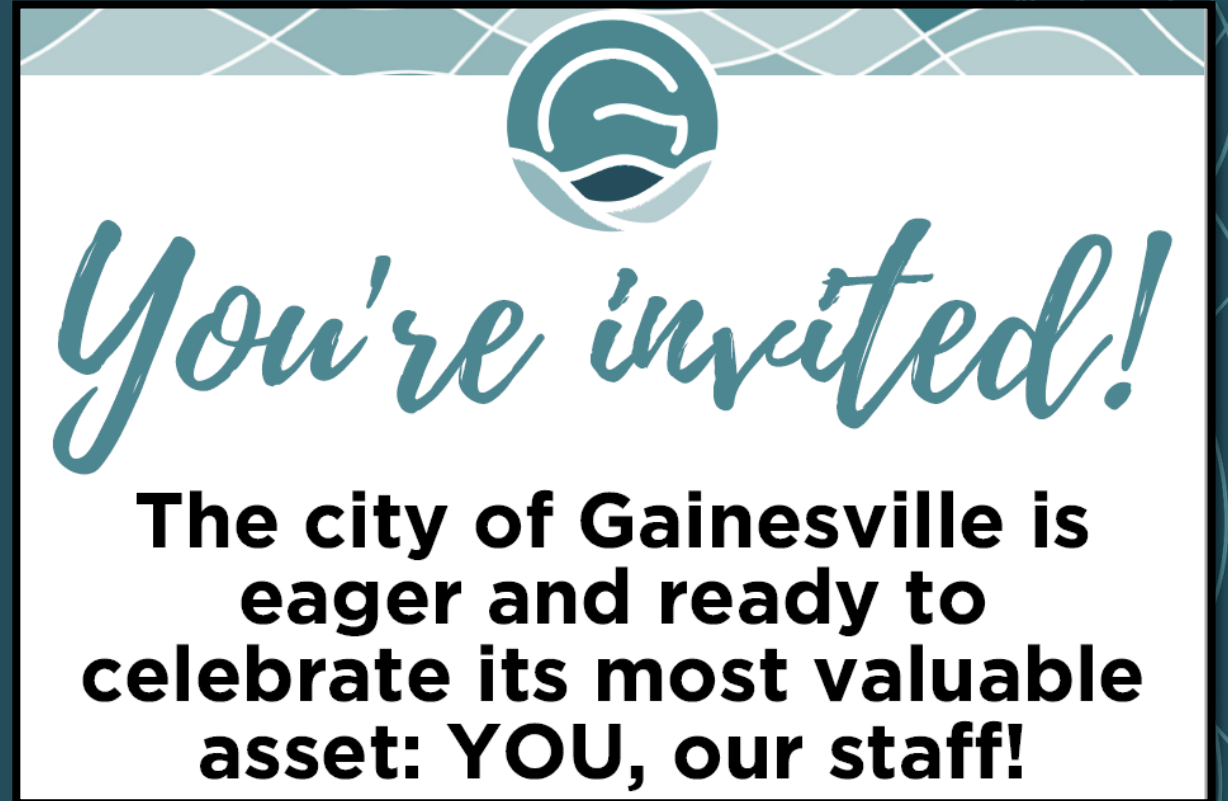

Hosted a  
very different  
socially  
distanced  
Open  
Enrollment

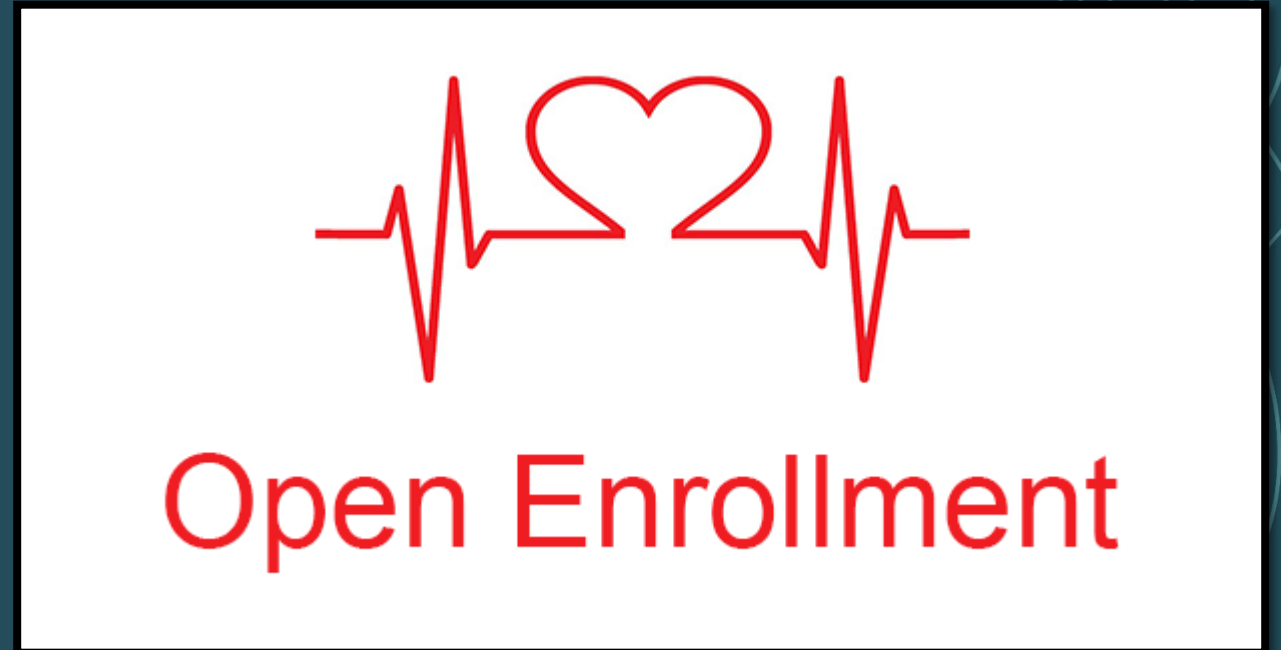

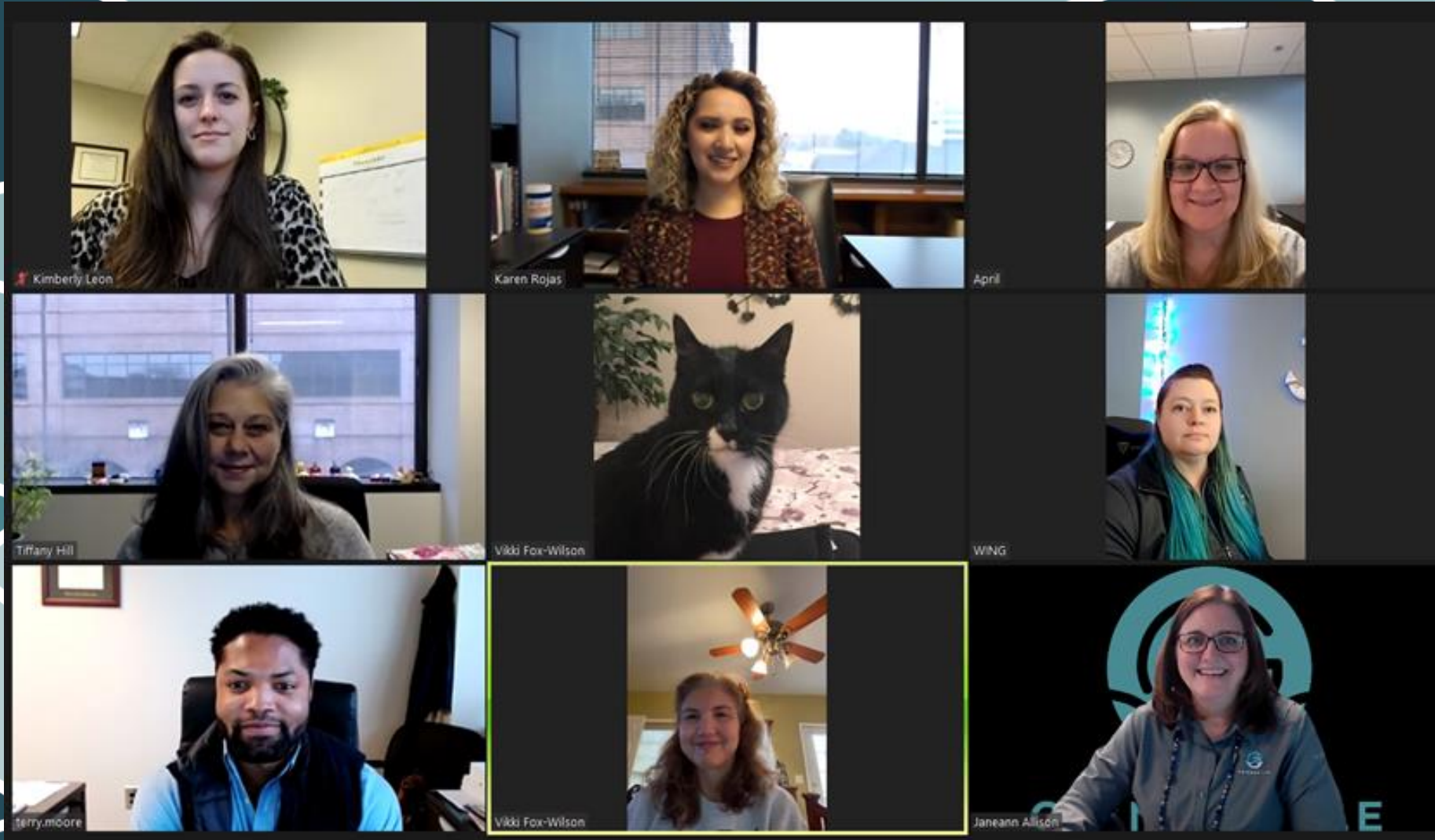

# CHALLENGES + OPPORTUNITIES

# CURRENT DISCUSSION: CHALLENGES + OPPORTUNITIES



**BUDGET PRIORITY: INTERNAL OPERATIONS | STRATEGIC AREA: CITYWIDE**

# Virtual Employee Engagement





“If you’re stuck using multiple HR platforms and old processes, it’s easy to get so bogged down in data that it hurts your efficiency and bottom line.”

# INITIATIVES

CURRENT DISCUSSION: INITIATIVES



5 systems combined into 1 solution!

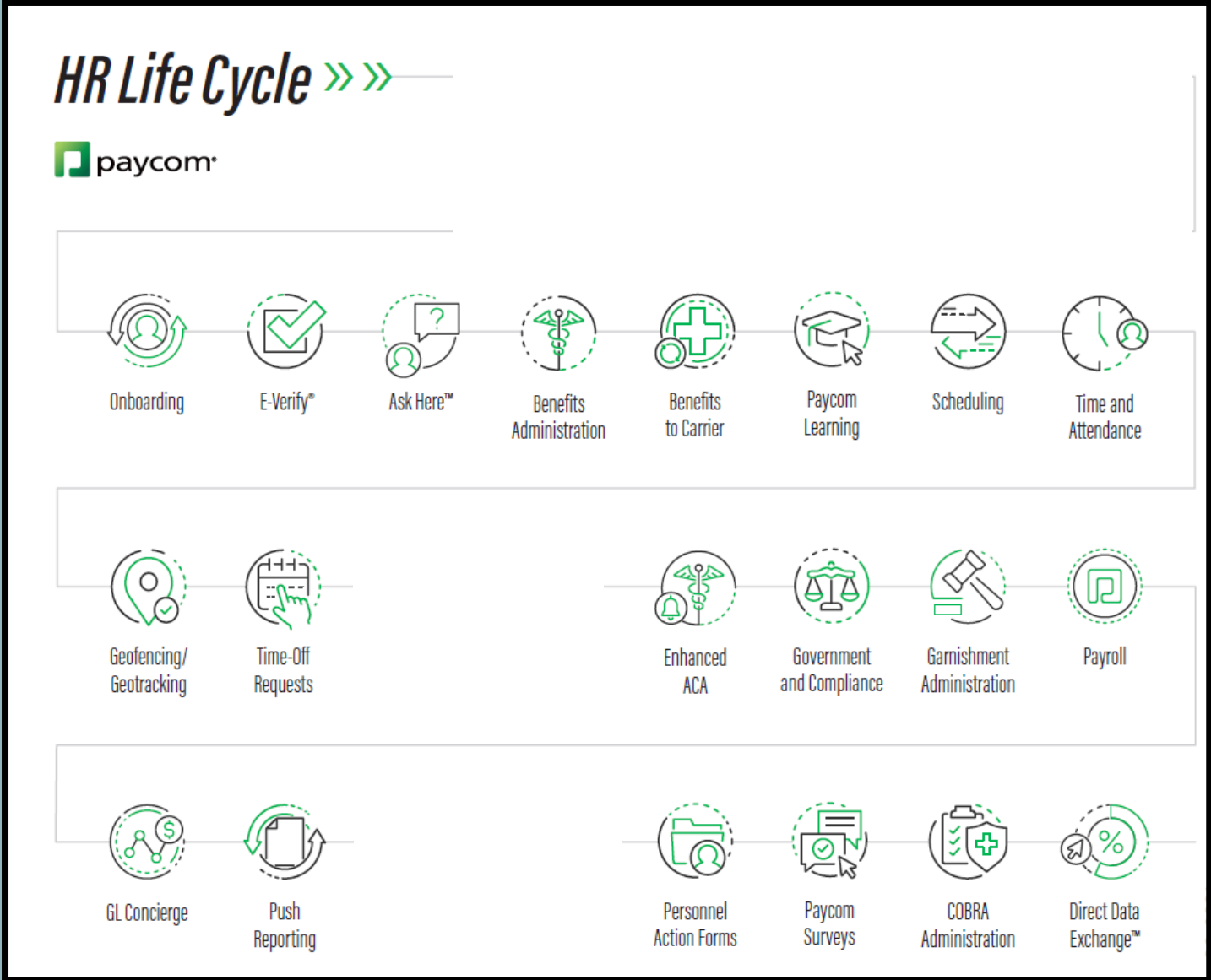

# Information Technology



# ACCOMPLISHMENTS



# Data Center Relocation Project

## CURRENT DISCUSSION: ACCOMPLISHMENTS

DWR Warehouse Network upgrade  
(new fiber and new 10g switching, and  
access control)

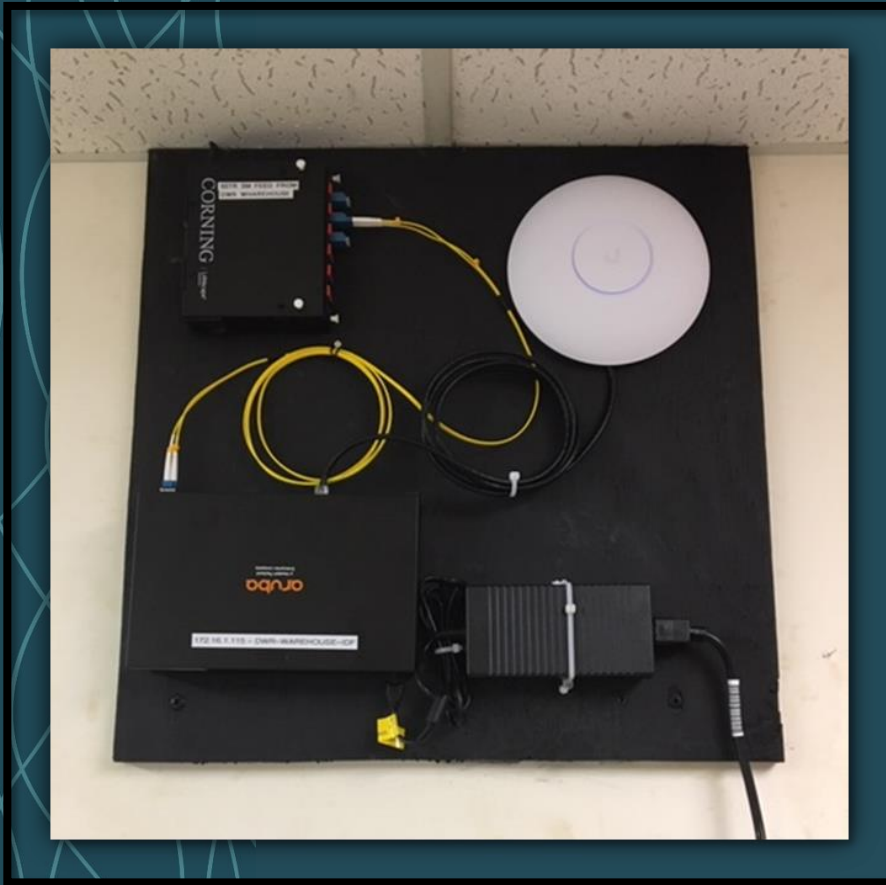

Operator Room renovations at Lakeside  
Lakeside IPTV/CCTV camera upgrades

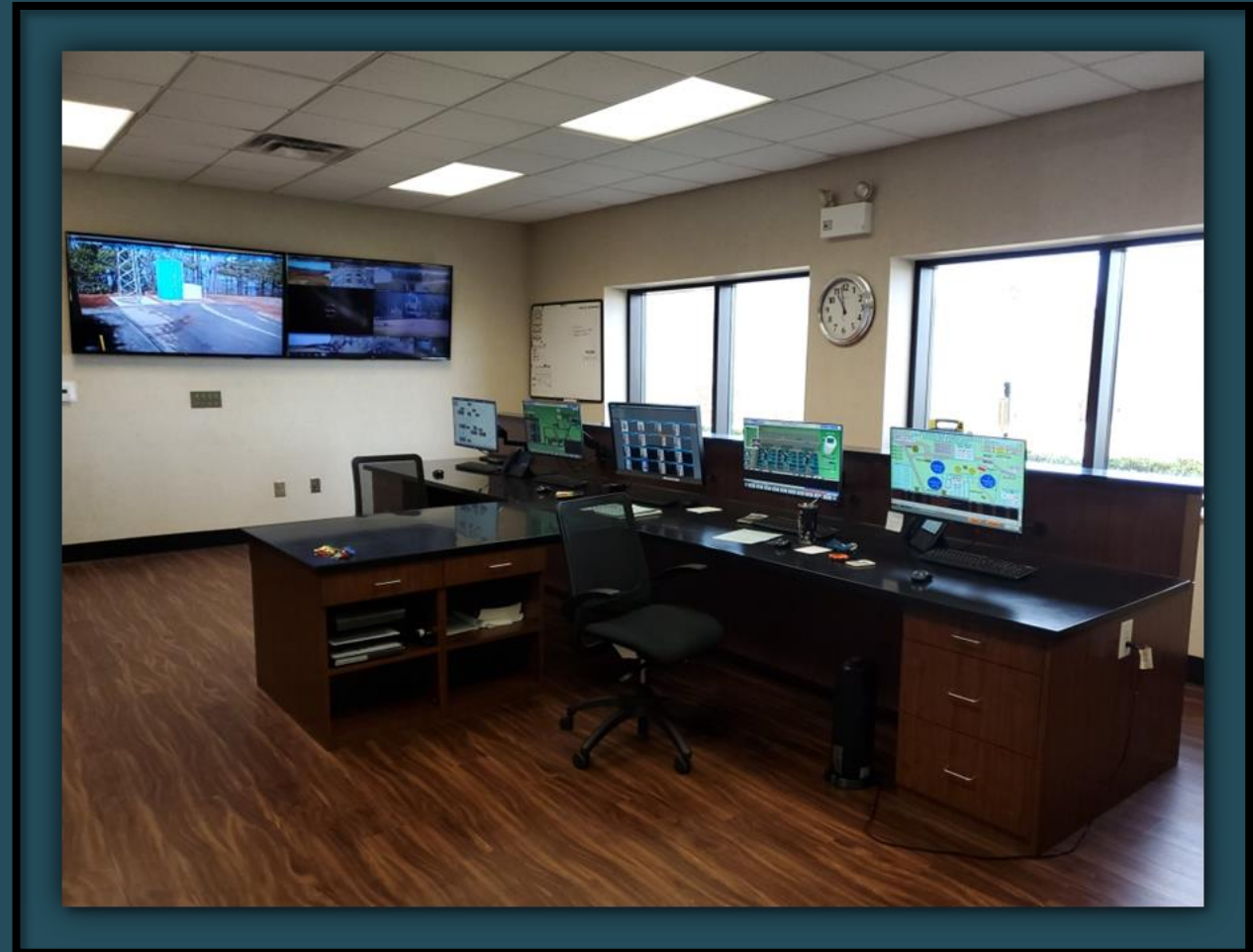

**BUDGET PRIORITY: INTERNAL OPERATIONS** | **STRATEGIC AREA: CITYWIDE**

## CURRENT DISCUSSION: ACCOMPLISHMENTS



Added additional  
NextGen Firewalls  
for internal network

**BUDGET PRIORITY: INTERNAL OPERATIONS** **STRATEGIC AREA: CITYWIDE**

# CURRENT DISCUSSION: ACCOMPLISHMENTS

Full major upgrade to New World ERP completed



COVID Laptop and Work from Home technology improvements



Windows 10 citywide upgrade



Deployment of new fleet of Police Body Cameras (Axon)



IT buildout for new Fire Station 2





# CHALLENGES + OPPORTUNITIES

# CURRENT DISCUSSION: CHALLENGES + OPPORTUNITIES



**BUDGET PRIORITY: INTERNAL OPERATIONS** | **STRATEGIC AREA: CITYWIDE**

# CURRENT DISCUSSION: CHALLENGES + OPPORTUNITIES



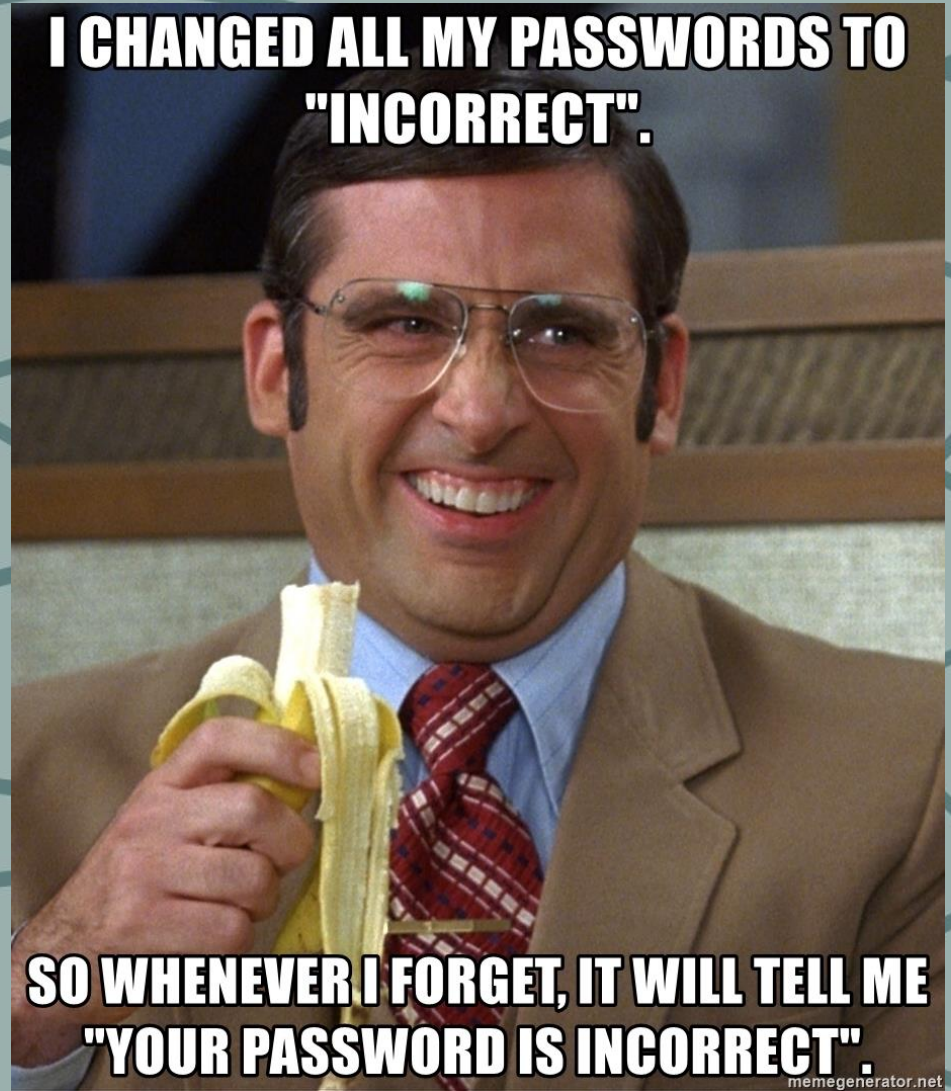

# INITIATIVES

CURRENT DISCUSSION: INITIATIVES

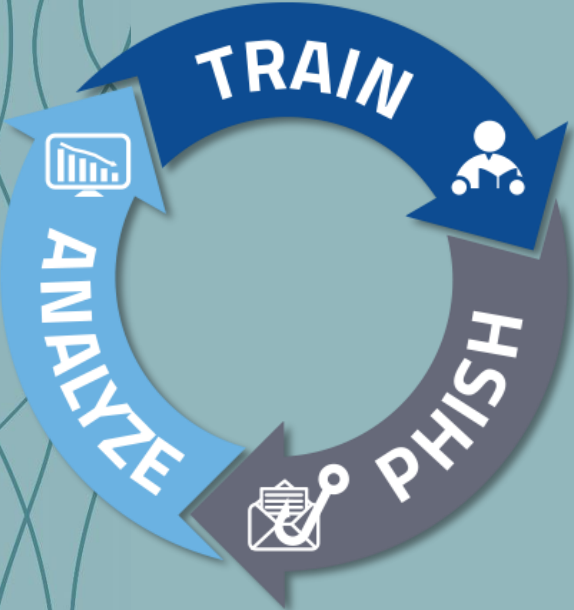

BUDGET PRIORITY: INTERNAL OPERATIONS | STRATEGIC AREA: CITYWIDE

# CURRENT DISCUSSION: INITIATIVES

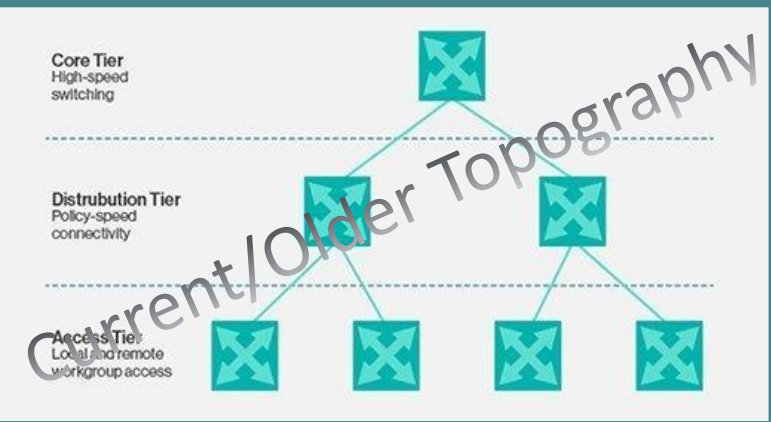
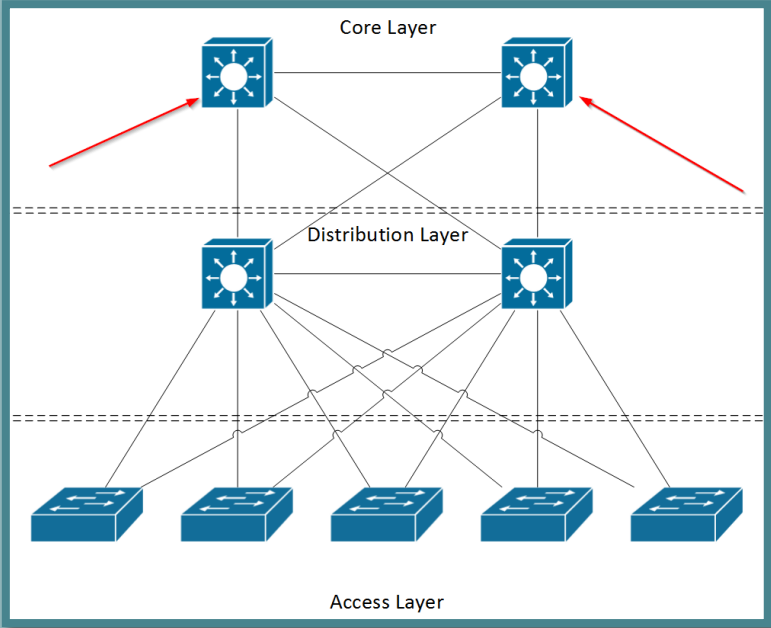

**BUDGET PRIORITY: INTERNAL OPERATIONS** | **STRATEGIC AREA: CITYWIDE**

# CURRENT DISCUSSION: INITIATIVES

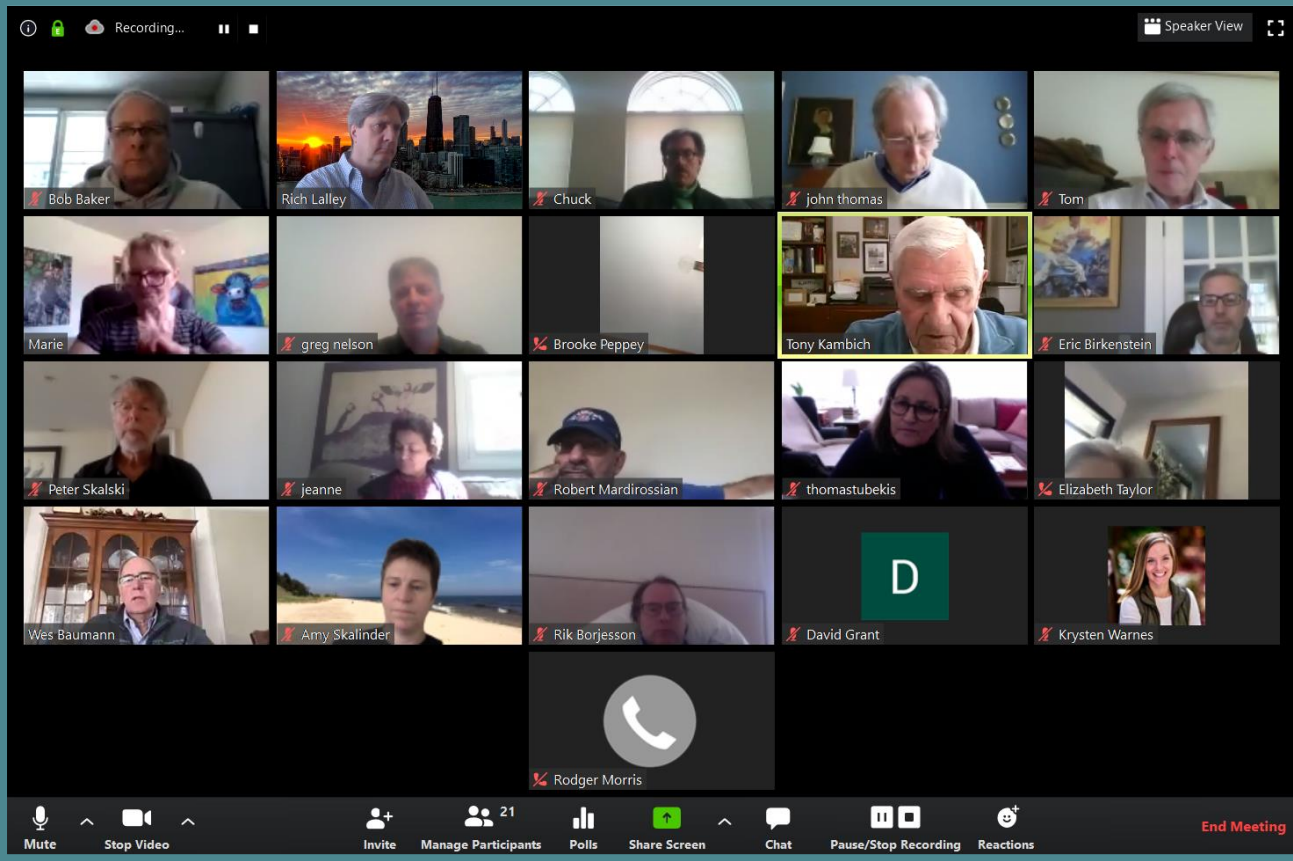

**BUDGET PRIORITY: INTERNAL OPERATIONS | STRATEGIC AREA: CITYWIDE**

# Municipal Court



# ACCOMPLISHMENTS

# CURRENT DISCUSSION: ACCOMPLISHMENTS



Courts at the  
crossroads

COVID-19 Plan

<b>City of Gainesville Municipal Court</b>						
<b>Case Activity Report During COVID 19</b>						
Operating under the Statewide Judicial Emergency Order						
Response to the COVID- 19 Pandemic						
Chief Justice Orders	Month	Municipal Court Deposits	PPS Deposits	Current Collections	Closed/ Adjudicated Cases	Comments
	March	61,463	39,558	101,021	530	Court Closed- 03-14
04/06/20	April	32,313	22,923	55,236	294	No Court
05/11/20	May	64,693	18,274	82,967	285	No Court
06/12/20	June	73,375	16,913	90,288	534	Court Opened- 07-22
07/10/20	July	104,043	21,285	125,327	607	Court
08/11/20	August	124,146	25,259	149,405	1,009	Court
09/10/20	Sept	132,935	28,679	161,614	864	Court
10/10/20	Oct	123,785	30,612	154,397	1,647	Court
10/10/20	Nov	96,289	27,012	123,301	826	Court
11/09/20	Dec	78,205	27,878	106,083	608	Court
<b>\$ Change</b>	2020	\$ 891,247	\$ 258,393	\$ 1,149,640	7,204	
<b>CY20-19</b>	2019	1,051,188	406,869	1,458,057	8,838	
	<b>Differences</b>	\$ (159,941)	\$ (148,476)	\$ (308,417)	\$ (1,634)	

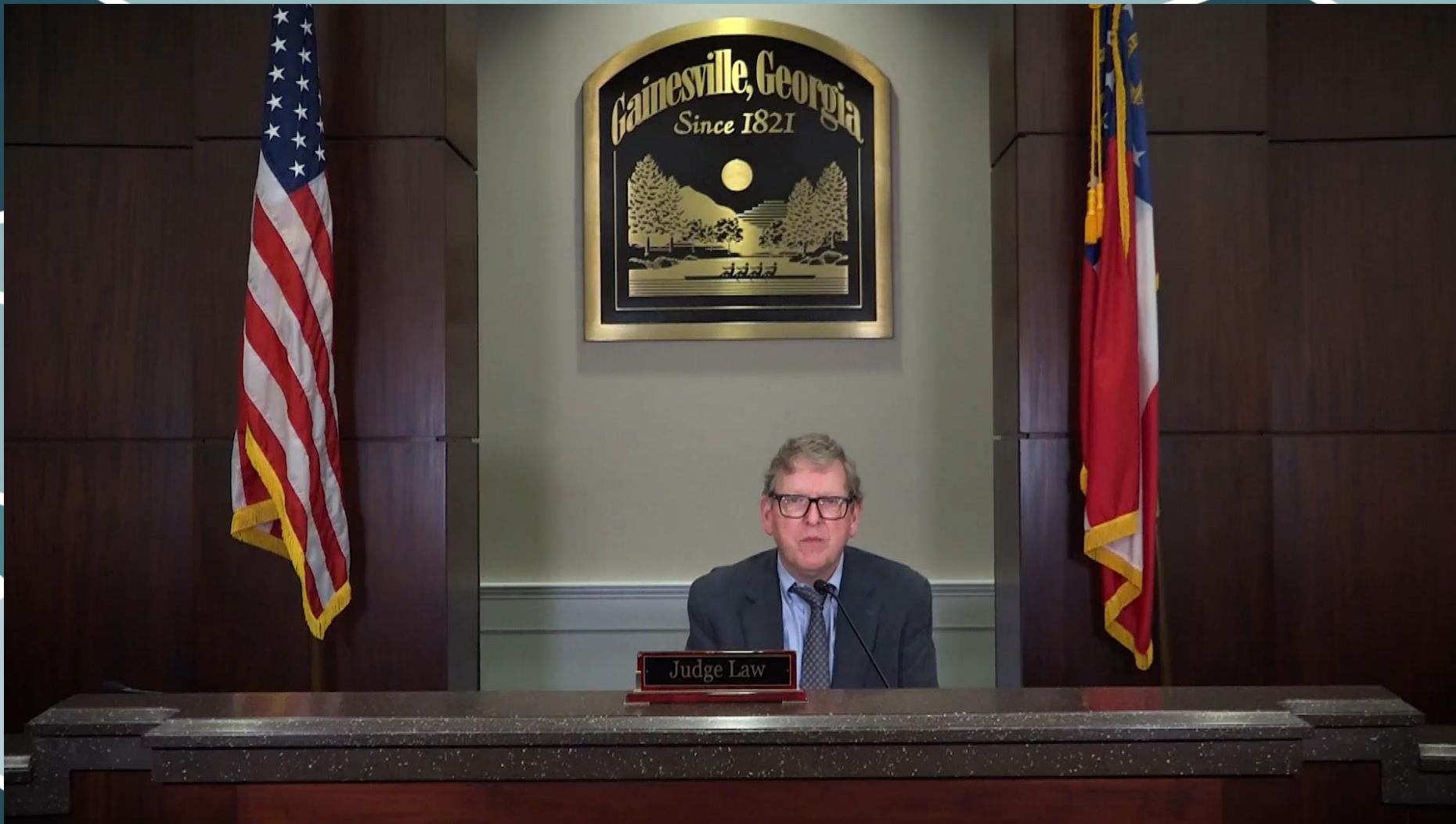

# CHALLENGES + OPPORTUNITIES

*The Greatest Balancing Act of the Year for Courts*

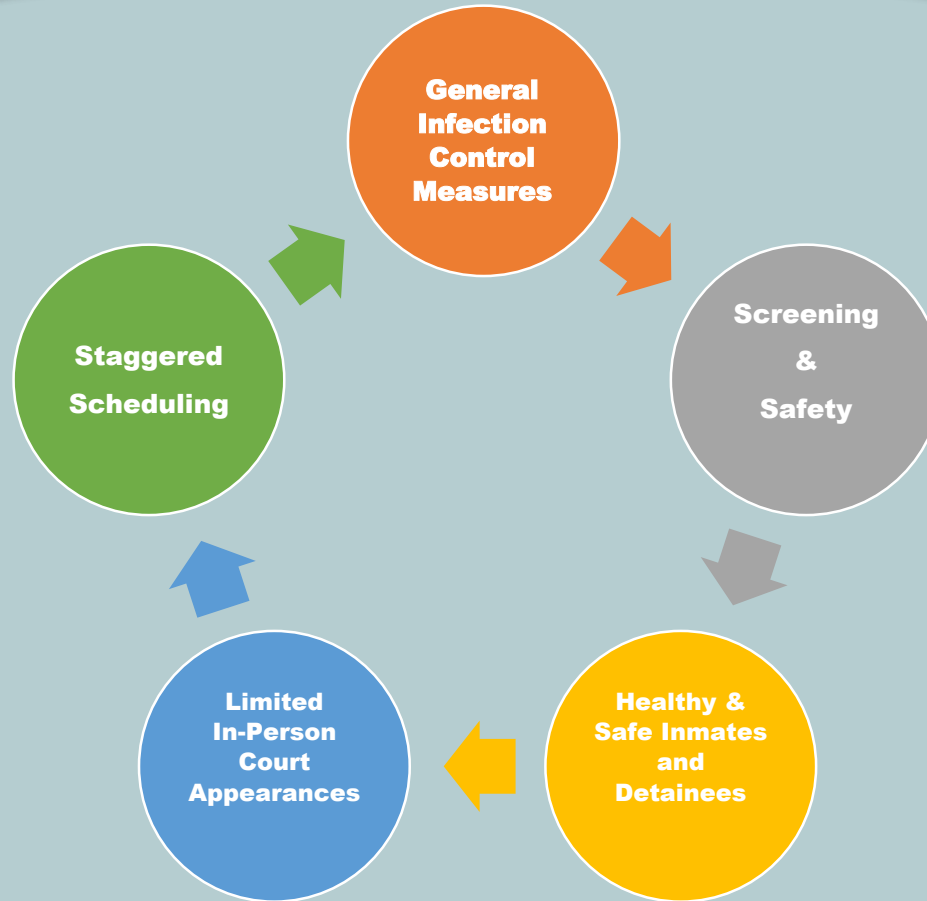

# Municipal Court



Angie Floyd, Manager



# INITIATIVES

# Municipal Court

## Working Together to Make Justice Work

### National Association for Court for Court Management

Development Program- the CORE program is a map for reaching these goals and a lens through which to view the profession; the program is based on the three modules.



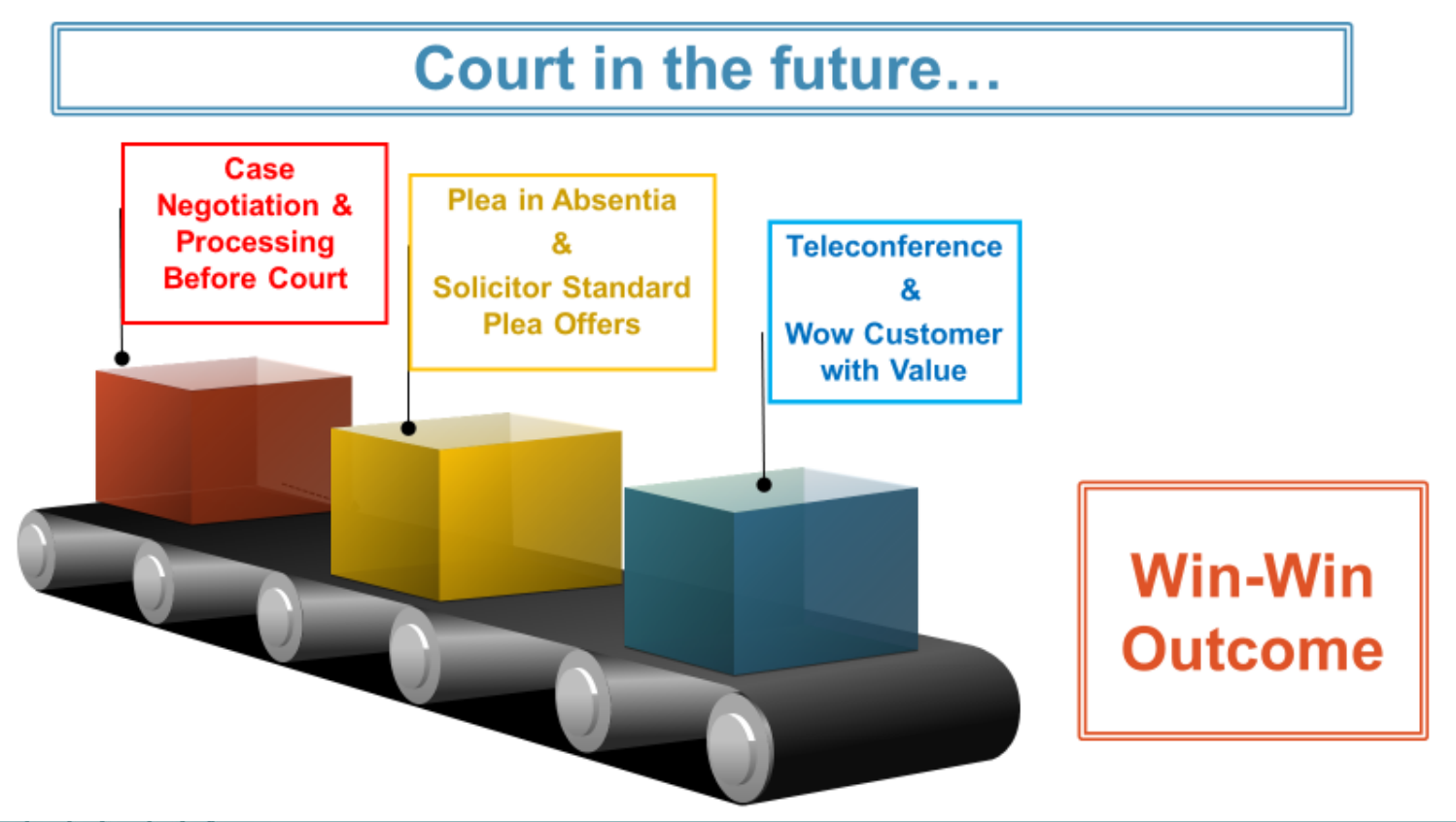

# Municipal Court



QUESTIONS?  
COMMENTS?  
CONCERNS?

**GAINESVILLE  
CITY COUNCIL  
RETREAT**

**2021-22 BUDGET PRIORITIES  
THE STATION – GAINESVILLE ADMINISTRATION BUILDING**

**Date Submitted:** 2/18/2021  
**Presenter:** Robyn Lynch  
**Item of Business:** • Tourism / CVB  
**Meeting Date:** 2/19/2021

---

**Purpose of Request:**

**History/Background:**

**Facts & Issues for Consideration:**

**Department Recommendation:**

**Department Director:**

---

**If funding is involved, are funds approved within the current budget?**

**Amount Requested:**

**Source of Funds:**

**Finance Comments:**

---

**Administrative Comments:**

---

**ATTACHMENTS:**

Description	Type
<input type="checkbox"/> FY21-22 Tourism / CVB Retreat Presentation	Powerpoint Presentation

# Tourism



## GAINESVILLE CITY COUNCIL RETREAT

2021-22 BUDGET PRIORITIES  
THE STATION – GAINESVILLE ADMINISTRATION BUILDING



**GIVE THE GIFT  
OF LOCAL**



**These gift  
certificates  
are good at  
over 25  
different  
businesses  
downtown!**



# ACCOMPLISHMENTS

# Main Street

## Promotions:

- Good People of Gainesville T-Shirts to support COVID-19 Fund
- **Downtown History Hunt**
- Virtual Lighting of the Chicken
- **Social Distance Social**
- School Music Concerts on the Square
- **‘Light Up the Town’ Christmas Contest and Parade**
- First Downtown Partnership with Road Atlanta and Moto America Superbikes
- Summer Mutts on Main

## Design:

- **Loading Zones on Downtown Square**
- Patriotic Banners on Historic City Hall
- Pandemic: Patriotic Lights Downtown
- Let There be Rock: Awning improvement via Facade Grant
- Revival of the Mobile Parklet
- New Public Art Installations
- **Ground Breakings and Renovations**
  - Skate Park Opening
  - Solis Gainesville
  - Gainesville Renaissance
  - Art Council Pavilion
  - Streetscaping Improvements on Washington St, Spring St, and Green St

## Economic Vitality:

- **Launch of Main Street Money Program**
- Over 1K new Facebook Likes
- Instagram Reach grew 63%
- Growth of 10 new or expanded small businesses downtown.
- Many Businesses took this time to do minor renovations to their buildings
- New Residential Growth building in both downtown and midtown

# CVB

- Implementation of the funding guidelines and use of the host fee calculator
- Visitors Center
- Deployment of the mobile kiosk
- Creation and implementation of Safecation and itineraries focused on needs
- **Creation/utilization of “hospitality sheets” which are tailored to incoming groups needs**
- Utilization of new lead program- allowing us to track leads and progress
- Promotion of kayak

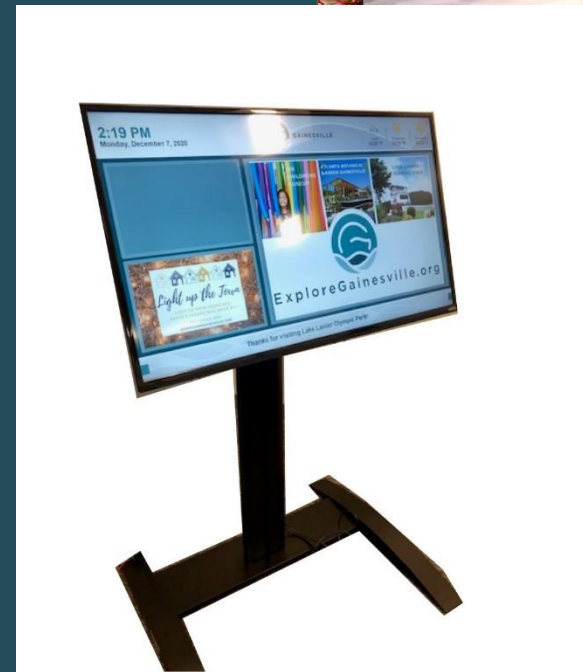
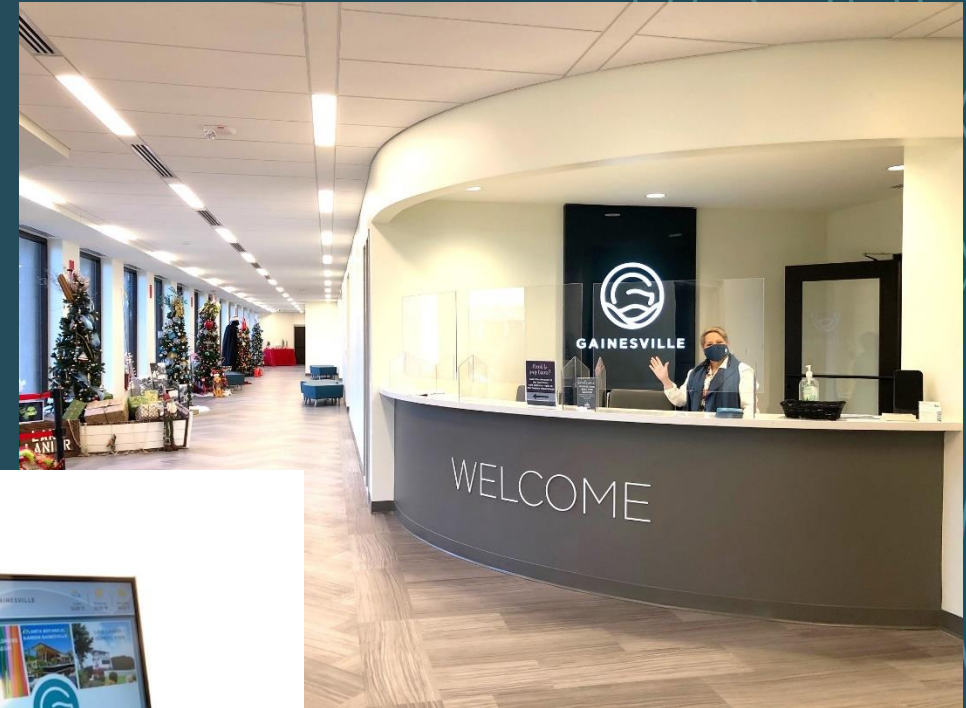

# Greater Gainesville Sports Alliance

Outdoor recreation contributes over \$780 BILLION to the US economy and supports 5.2 Million Jobs

Sports Tourism contributes \$11 BILLION Annually

Sports Tourism produces over \$15 Million in Economic Impact to the Gainesville Economy Annually

- Exploratory Committee
- Advisory Committee
- Research and Development of Sports Planning Guide
- Sports Alliance Kickoff – March 2021
  - Membership
  - Economic Impact
    - Overnight Stays
    - Direct Spending
    - Indirect Spending

# Lake Lanier Olympic Park

- Food Truck Friday events were reformatted to adapt to COVID-19 pandemic
- Applied over 100 tons of fresh sand to public beach
- Moved ticket booth to boathouse side to help LCKC with rentals
- Completed sheet rock repair in boathouse to correct safety issues
- Painted inside of office building
- **Completed relocation of plaza rings and created a monument area**
- **Installed permanent pumps in the bottom of tower to move flood waters**

- **Met revenue goals despite the pandemic:**
  - 2019 ACA Canoe/Kayak Nationals
  - 2019 Lake Lanier Dragon Boat Festival
- Reopened the park and the boathouse for our visitors and members following State and CDC COVID-19 guidelines
- Developed a flood plan to better help prevent serious damage during future flooding events
- Gates were installed on the park side to facilitate overnight park closure for specific high-traffic holidays

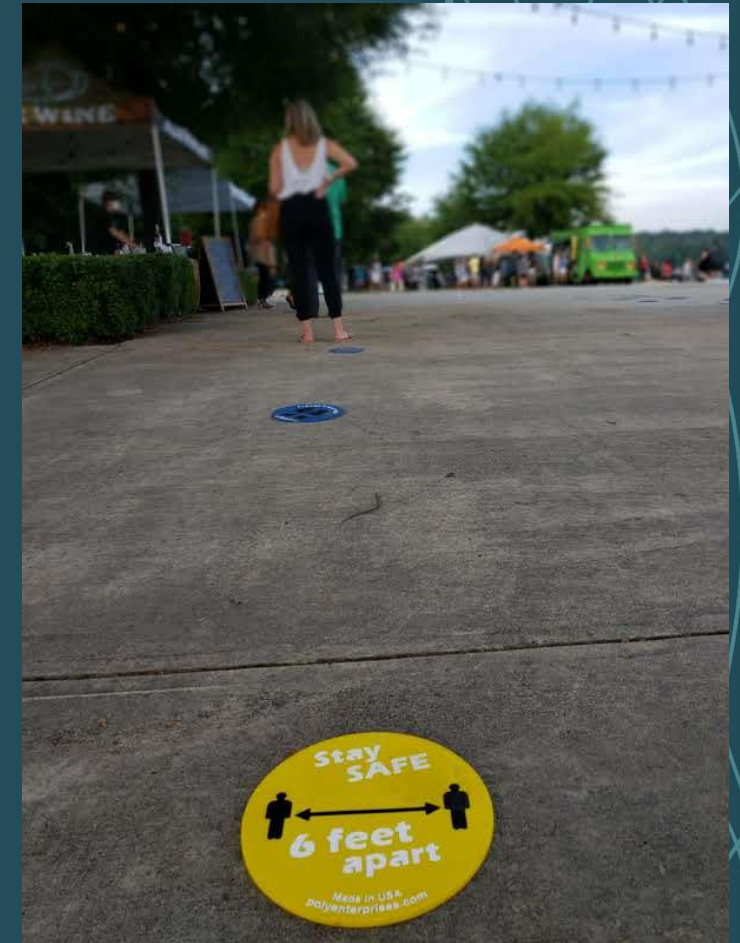



# CHALLENGES + OPPORTUNITIES

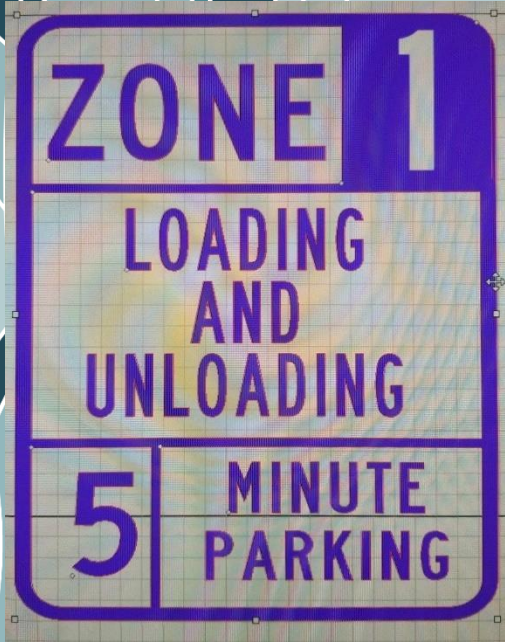

### Challenges

- Pandemic, elimination of downtown events, non face-to-face interaction with downtown community members
- Lost 10 small businesses downtown

### Opportunities

- Focus on Building Online and Digital Resources
- Time for Learning Opportunities for New Main Street Manager
- **Innovative thinking for annual events**
- With focus on virtual during pandemic, social media innovations and promotions

# Main Street

## CVB

### Challenges:

- Restriction of travel and closing of attractions due to pandemic
- Assuring visitors that it is safe to travel
- **Finding locations to host events that were not cancelled**
- Marketing Gainesville as a tourist destination when there is fear of traveling
- **Keeping morale up with hoteliers and attractions**
- Communication with partners due to layoffs and closures

### Opportunities:

- **Pivoting focus to look at non-conference, business travel overnight stays**
- Creating opportunities of safe travel that will carry on past the pandemic
- Creating interactive and engaging ways to communicate with the public- i.e.- safecation suggestions, interactive online games and activities that also provide educational information about things to do and see in Gainesville
- Review and revise during slower times- such as funding guidelines and social media strategies
- Focus on sports events and reaching out to a market that we've not tackled
- Website and digital strategies moving forward-during this time we've realized that there are other ways to communicate and engage visitors through virtual tours, online activities and offering ways to safely travel
- Zoom and group online communications

# CURRENT DISCUSSION: CHALLENGES + OPPORTUNITIES

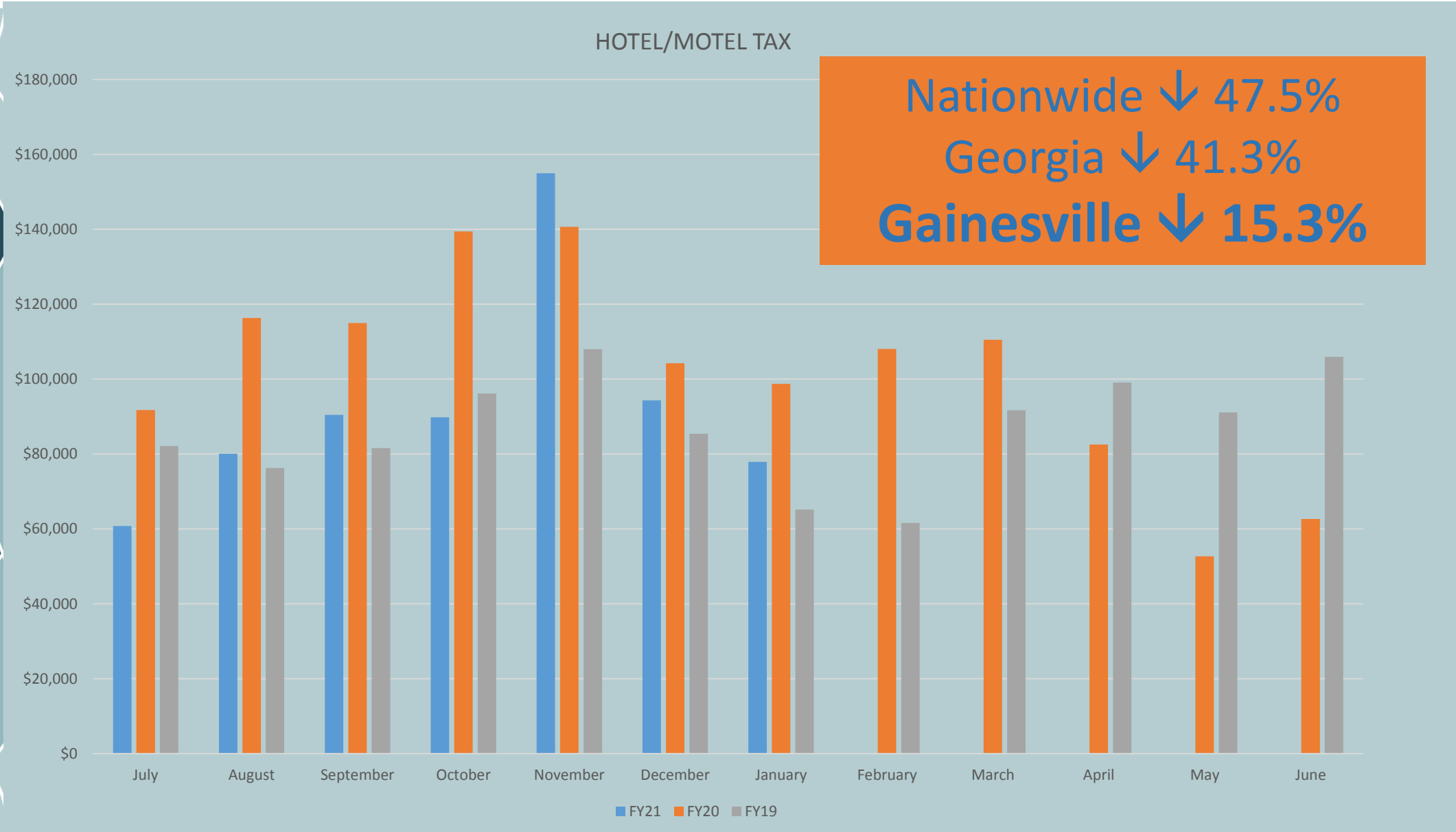

# Lake Lanier Olympic Park

- COVID-19 and its impact on athletic events and social gatherings was 2020's biggest challenge
- **Increased daily park use required a restructuring of staff activities**
- LLOP had to develop COVID-19 precautions and guidelines for each of our events as well as daily park activities
- We experienced two floods and numerous significant storms throughout 2020



- **We were able to host some weekday events in the fall**
- **Were able to host several first time events**
- The times gave the park over 9,000 photos from the Olympics and we were able to convert them to digital





# INITIATIVES

# Main Street



- Finalizing Pole Banner Project
- Expanded Outdoor Dining in on the Historic Square
- Introduce Sound System on the Downtown Square
- Online Business Portal to assist potential and current businesses
- Empty Building Initiative: Clean up windows and market available spaces, based on feedback from downtown community



# CVB

- Update of Visitor Guide- utilizing new branding and creating a flip page digital version
- **Website- expand/create to market Gainesville’s tourism, attractions, restaurants and activities**
- Grow and recruit events as market returns
- Plan and schedule hotelier meetings to create a forum and connection between the CVB and hotels
- Re-visit social/digital media and strategy for short term marketing efforts and explore other platforms- creation of a blog

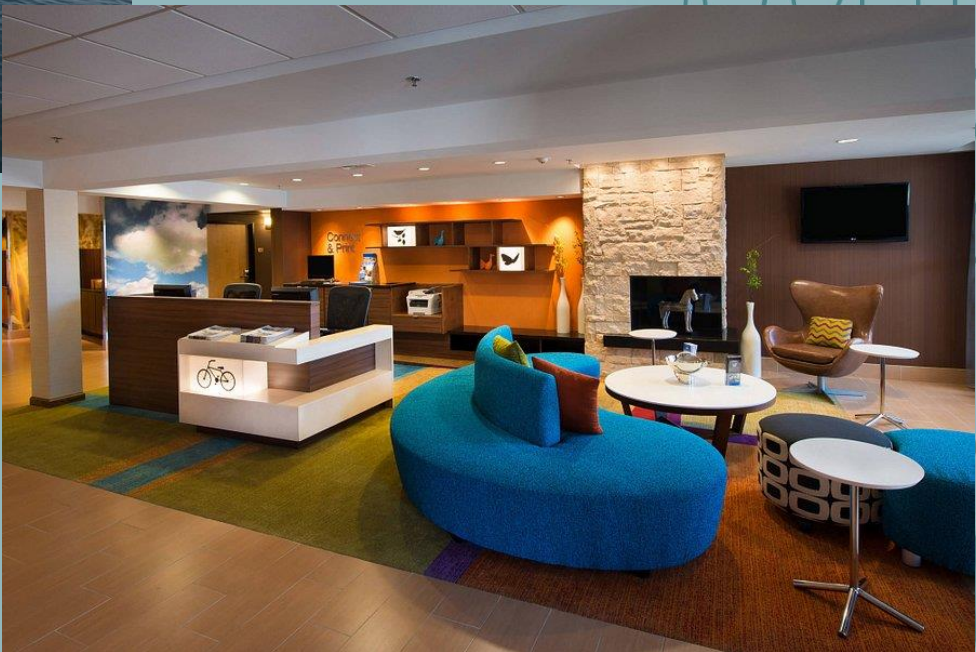

# CURRENT DISCUSSION: INITIATIVES



- To utilize and market sports planning guide to sports planners through marketing and attending sports planning conferences
- Market Gainesville as a premier sports and outdoor recreation destination
- Partner with sports venues and clubs to recruit new sporting tournaments



# Lake Lanier Olympic Park



- Continue providing a space for the public to recreate and gather safely and comfortable
- **Summer 2021 – Completion of new park restroom**
- **Fall 2021 – Groundbreaking on new boathouse**
- **Continue Partnership with Lake Lanier Olympic Park Foundation**
  - 2020 - \$25k Investment in the Olympic Ring Plaza
  - 2021 - \$10K Investment in new courtesy dock
  - 2021 – Fundraising efforts begin for a \$1.5M investment in an additional new courtesy dock, sidewalks and outdoor entertainment venue

# Lake Lanier Olympic Park





QUESTIONS?  
COMMENTS?  
CONCERNS?

**GAINESVILLE  
CITY COUNCIL  
RETREAT**

**2021-22 BUDGET PRIORITIES  
THE STATION – GAINESVILLE ADMINISTRATION BUILDING**

**Date Submitted:** 2/18/2021  
**Presenter:** Phillippa Lewis Moss  
**Item of Business:** • Community Service Center / WeGo  
**Meeting Date:** 2/19/2021

---

**Purpose of Request:**

**History/Background:**

**Facts & Issues for Consideration:**

**Department Recommendation:**

**Department Director:**

---

**If funding is involved, are funds approved within the current budget?**

**Amount Requested:**

**Source of Funds:**

**Finance Comments:**

---

**Administrative Comments:**

---

**ATTACHMENTS:**

Description	Type
<input type="checkbox"/> FY21-22 CSC / WeGo Retreat Presentation	Powerpoint Presentation

# Community Services



## GAINESVILLE CITY COUNCIL RETREAT

**FY22 BUDGET PRIORITIES  
THE STATION – GAINESVILLE ADMINISTRATION BUILDING**



# ACCOMPLISHMENTS

# 2020 CENSUS 99.99% Complete Count!

United States®  
**Census**  
**2020**

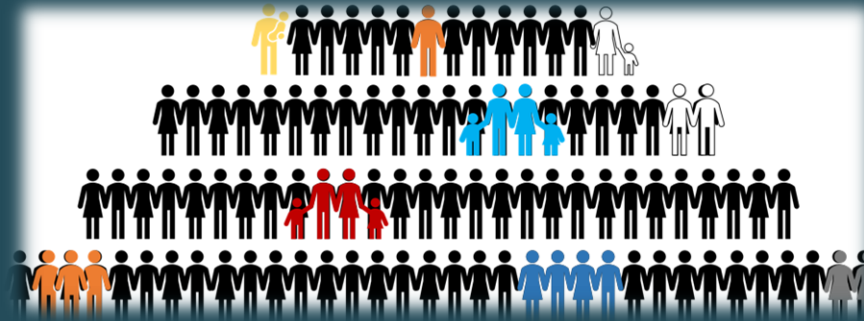

United States®  
**Census**  
**2020**

## CURRENT DISCUSSION: ACCOMPLISHMENTS



WEGO

2,500  
RIDES  
IN FIRST  
60 DAYS!





## Food Resources

# SENIOR NUTRITION PROGRAMS THRIVE



- Approximately 50 new clients are added to Meals on Wheels Program each month!
- 500+ Current Meals on Wheels & Senior Life Center Clients



# CHALLENGES + OPPORTUNITIES

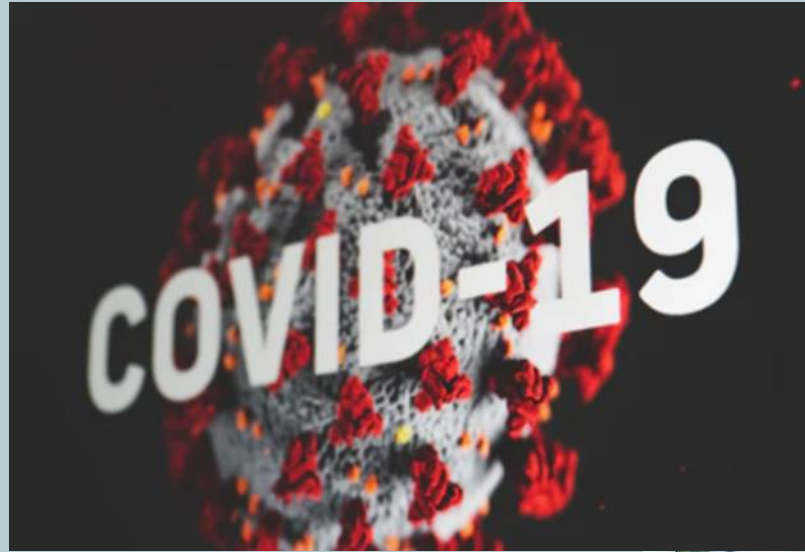

# VACCINATE STAFF, SENIOR CLIENTS & VOLUNTEERS



*Return to Daily Hot Meals  
Deliveries & Congregate Meal Site*



# INITIATIVES

## Mobile Meals App

**AUTOMATE MEAL DELIVERY**



- *From Route Sheets to Computer Tablets*
- *From Written Notes to GPS Coordinated Mapping*
- *From Approximate Delivery Times to Exact Times*
- *From Confusing Meal Synchronized Audits*

*Send Messages \* Collect Electronic Signatures  
Time Stamp Deliveries \* Important Client Notes*

# SERVTRACKER

...improving the way we account for meal delivery



# My Senior Center ...automating senior services



- ✓ Easy to use
- 🔑 Secure
- ☁️ Cloud-Based
- ⚙️ Customizable

# New Age-Friendly Community Designation

*Gainesville/Hall County will be one of 448 Age-Friendly Programs in the United States. This designation signifies to others that we have done the planning work to make our community easily accessible to older adults.*

Created by the World Health Organization (WHO) in 2006

## AARP Livable Communities

The **AARP Network of Age-Friendly States and Communities** serves as a catalyst to educate local leaders (both elected officials and engaged residents) and encourage them to implement the types of changes that make communities more livable for people of all ages, especially older adults.

The network provides cities, towns, counties and states with the resources to become more age-friendly by tapping into national and global research, planning models and best practices.

Membership in the AARP Network of Age-Friendly States and Communities means that a community's elected leadership has made a commitment to actively work with residents and local advocates to make their town, city, county or state an age-friendly place to live.

**A community's age-friendly leaders and champions will likely include:**

- Elected officials
- Government agencies
- Nonprofit organizations and foundations
- Academic institutions
- Area Agencies on Aging
- Community coalitions
- Local businesses
- Chambers of Commerce
- Residents and lots of volunteers

**Visit the Age-Friendly Resources page to download or order this introductory booklet.**

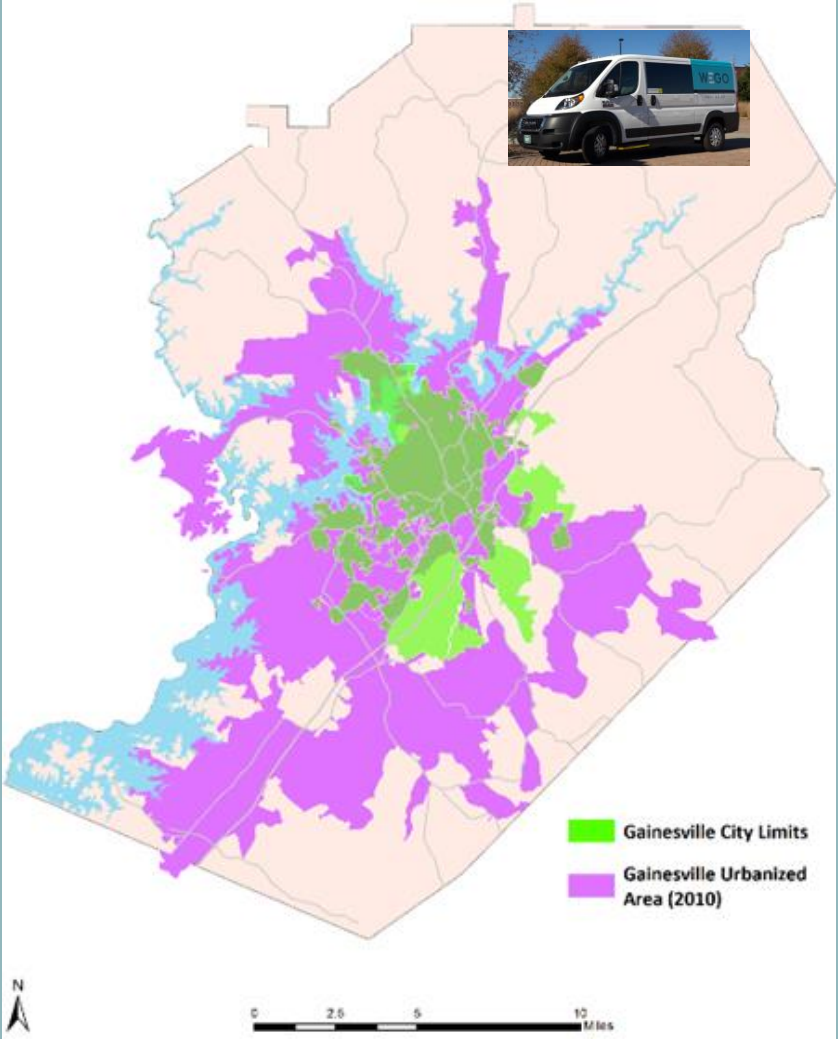

# EXPAND WeGo Throughout Hall County

- *From 4 Vehicles to 15 Vehicles*
- *From 32 Seats to 130 Seats*
- *Projected 100,000 Rides in FY22*

# Nurture Community Partnerships





QUESTIONS?  
COMMENTS?  
CONCERNS?

**GAINESVILLE  
CITY COUNCIL  
RETREAT**

**2021-22 BUDGET PRIORITIES  
COMMUNITY SERVICE CENTER**

**Date Submitted:** 2/18/2021  
**Presenter:** Jay Parrish  
**Item of Business:** • Police  
**Meeting Date:** 2/19/2021

---

**Purpose of Request:**

**History/Background:**

**Facts & Issues for Consideration:**

**Department Recommendation:**

**Department Director:**

---

**If funding is involved, are funds approved within the current budget?**

**Amount Requested:**

**Source of Funds:**

**Finance Comments:**

---

**Administrative Comments:**

---

**ATTACHMENTS:**

Description	Type
<input type="checkbox"/> FY22 Police Retreat Presentation	Powerpoint Presentation

# Police Department



## GAINESVILLE CITY COUNCIL RETREAT

**2021-22 BUDGET PRIORITIES  
THE STATION – GAINESVILLE ADMINISTRATION BUILDING**



# ACCOMPLISHMENTS

# Co-Responder Mental Health Clinician

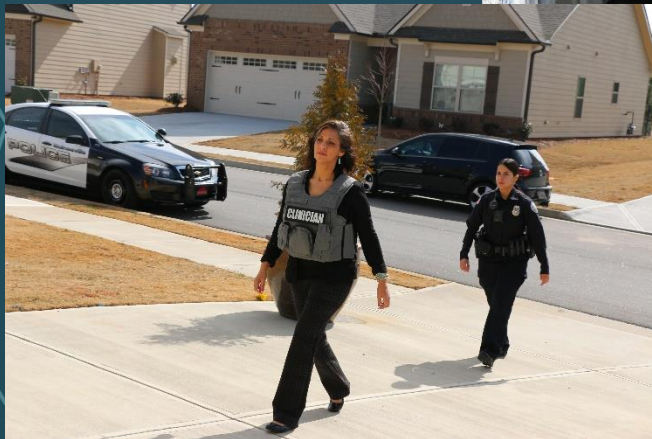

# North Precinct Property Purchase





# Reduction in Major Crimes

Crime	Rate Reduction
Drugs and Narcotics	-28.71%
DUI	-23.43%
Burglary	-4.73%

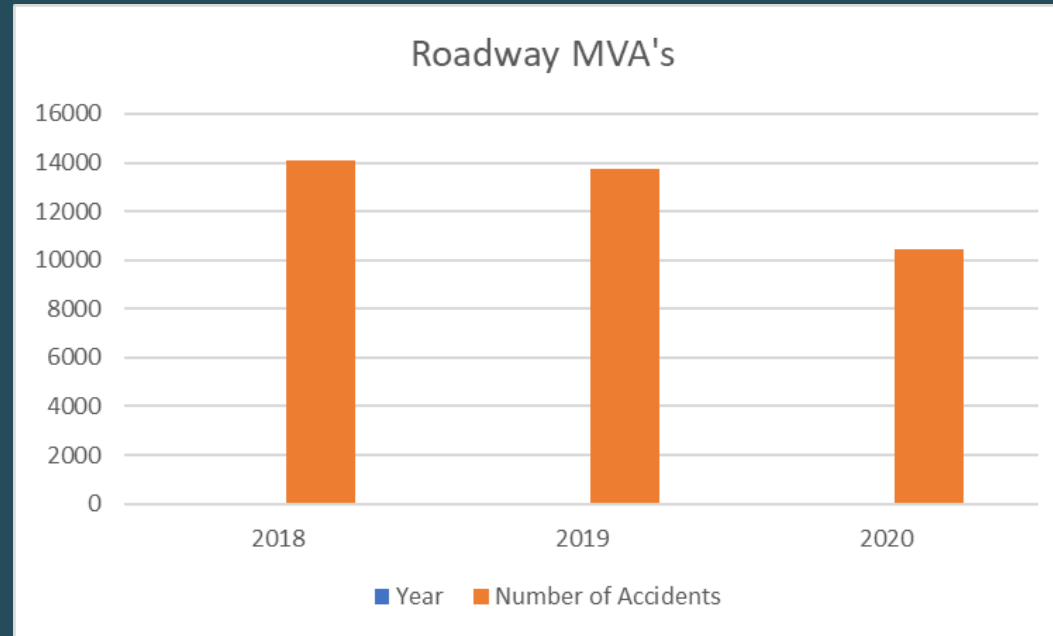

Reduction  
in  
Roadway  
MVA's

**24.91% Decrease!!!!**

# Policing in a Pandemic

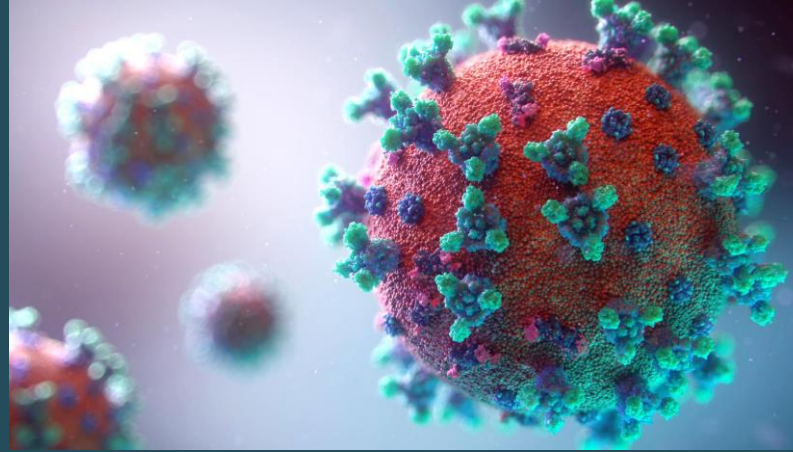



# CHALLENGES + OPPORTUNITIES

# Police Accountability





Growth  
(Traffic)

# Workforce Development



**GAINESVILLE POLICE SPOTLIGHT**



**Current Role:**  
Patrol Officer

**Officer Since:**  
2018

**Interests:**  
Spending time with family, reading, boxing, & shopping

**Q&A:**  
What skill/talent do you have that is unrelated to your profession?  
"I can play the flute! I started playing in 5th grade. I also play soccer."

**Officer JaLisa Dickerson**

Professionalism • Integrity • Loyalty • Leadership • Accountability • Respect



# Fleet Maintenance



# Fleet Maintenance

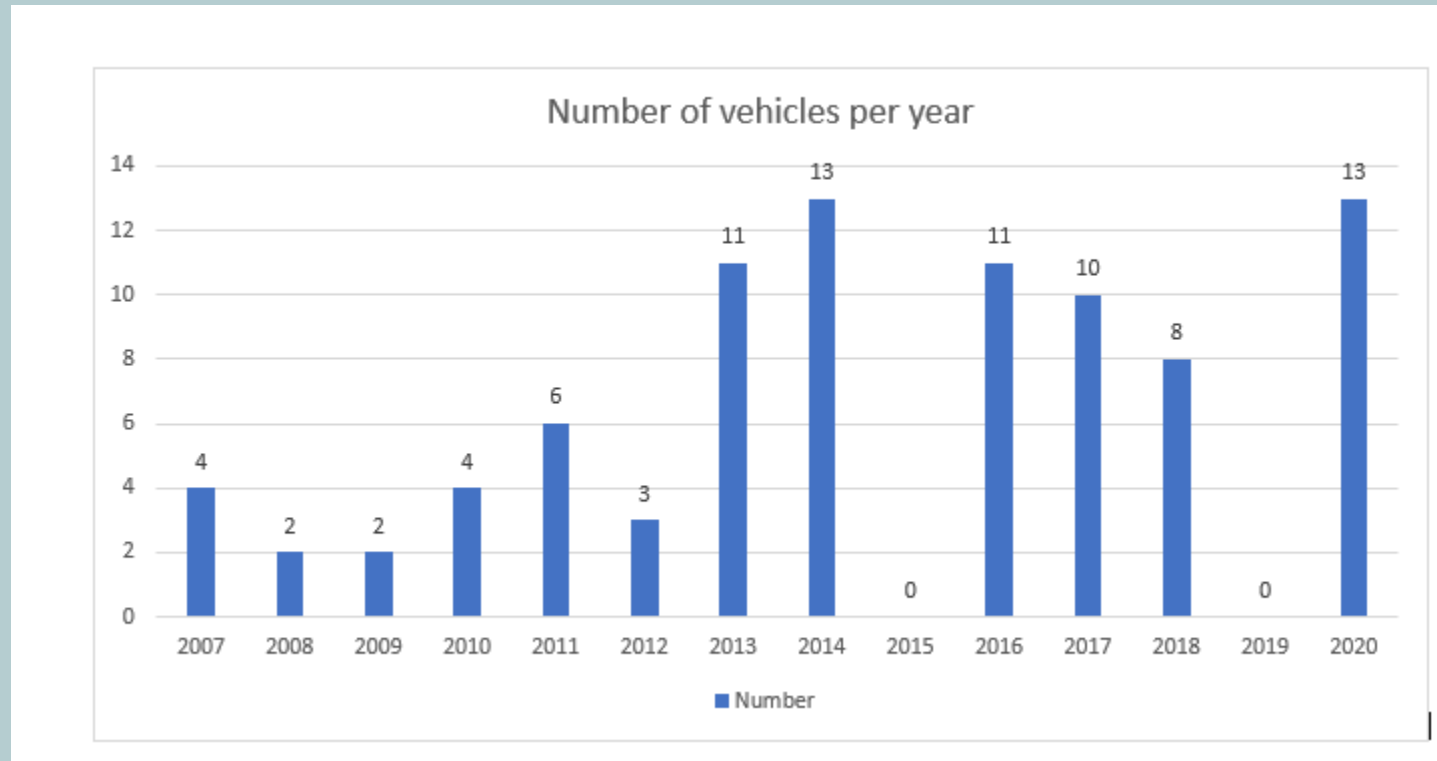

# Fleet Maintenance

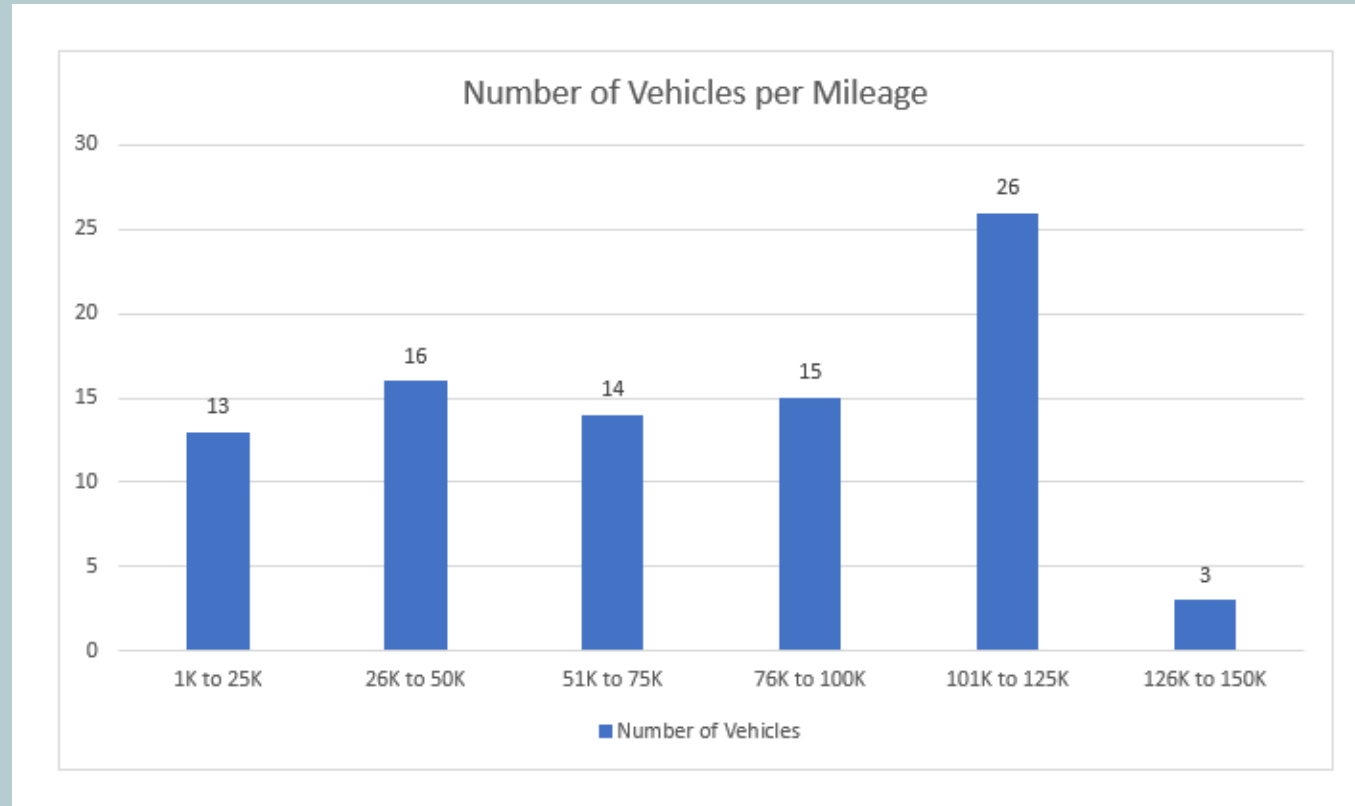



**PLS  
DNT  
TXT  
+  
DRIVE**



### 3 Basic Traffic Laws Regarding Traffic Control:

1. Obey traffic control devices, such as lights and signs (including those painted on the road surface.) O.C.G.A. 40-6-20
2. Obey public safety officers or authorized personnel even if it contradicts traffic control device. O.C.G.A. 40-6-2
3. Do not drive on a closed road (construction, parade, etc.) O.C.G.A. 40-6-20



# INITIATIVES



# Vehicle Accident Reduction

# Youth Programs

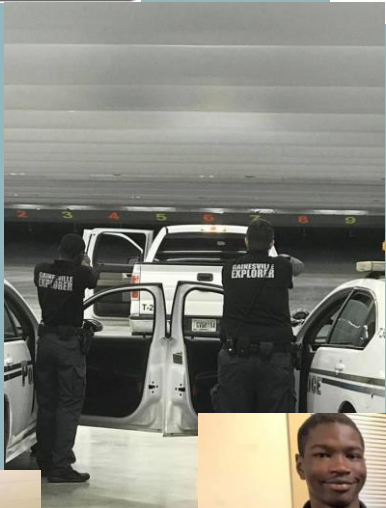

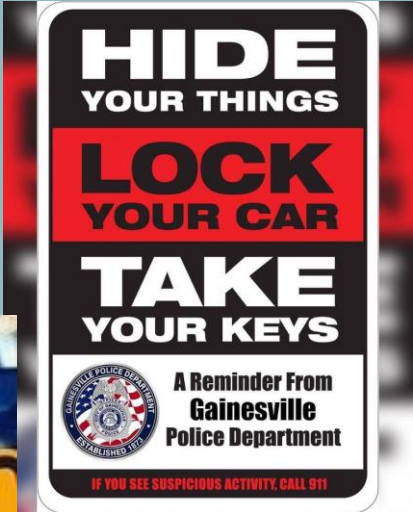
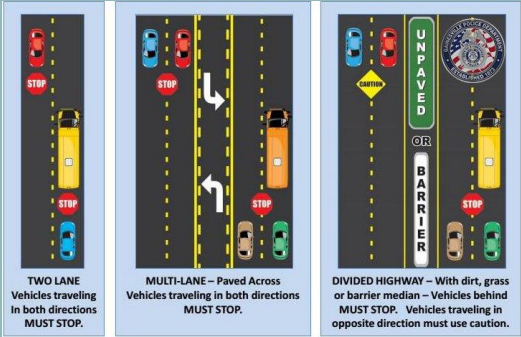

# Social Media Campaigns

CURRENT DISCUSSION: INITIATIVES

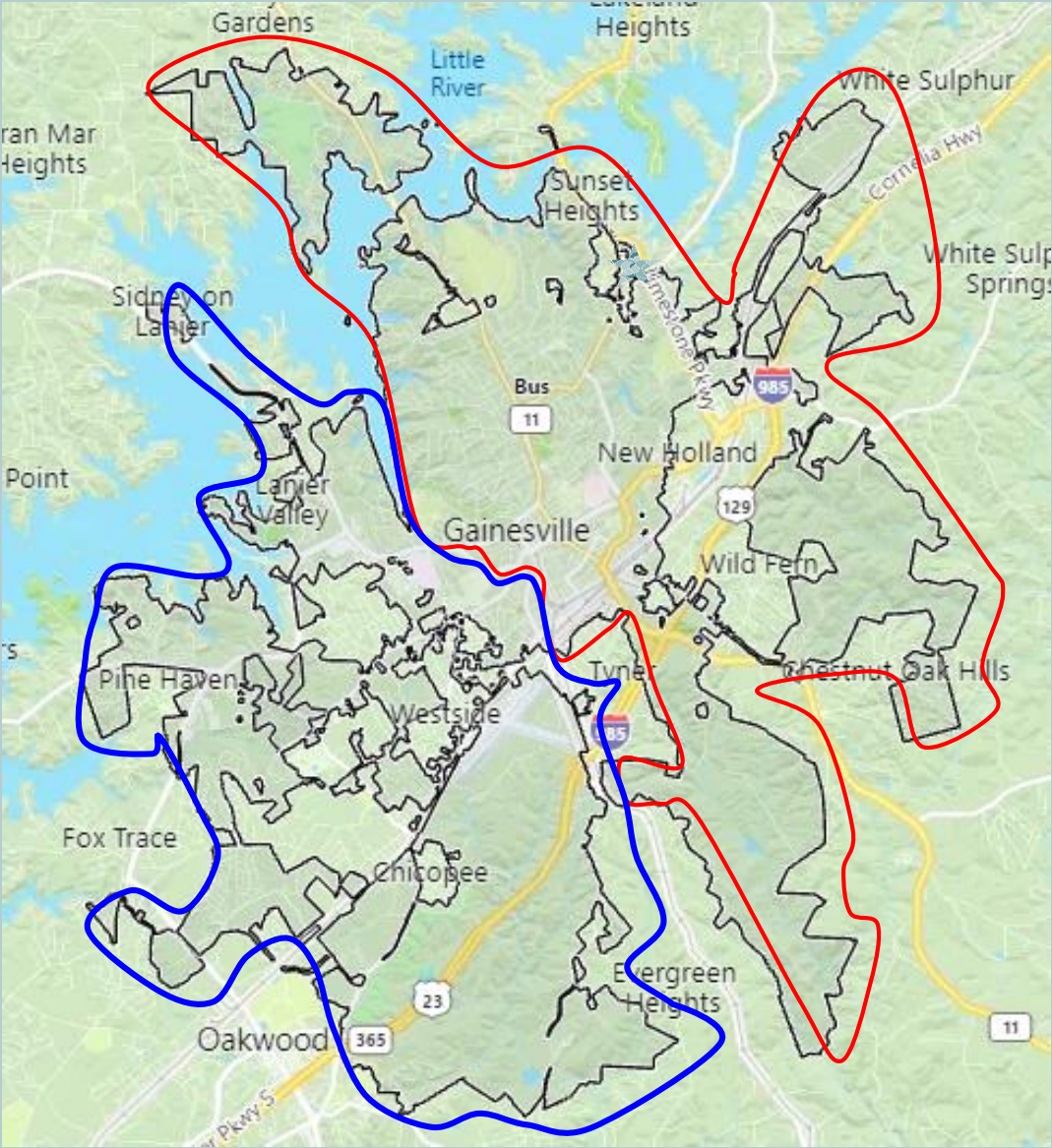

# Police Tax Districts

**BUDGET PRIORITY: INTERNAL OPERATIONS** | **STRATEGIC AREA: CITYWIDE**



QUESTIONS?  
COMMENTS?  
CONCERNS?

**GAINESVILLE  
CITY COUNCIL  
RETREAT**

**2021-22 BUDGET PRIORITIES  
THE STATION – GAINESVILLE ADMINISTRATION BUILDING**

**Date Submitted:** 2/18/2021  
**Presenter:** Kate Mattison  
**Item of Business:**

- Parks & Recreation

**Meeting Date:** 2/19/2021

---

**Purpose of Request:**

**History/Background:**

**Facts & Issues for Consideration:**

**Department Recommendation:**

**Department Director:**

---

**If funding is involved, are funds approved within the current budget?**

**Amount Requested:**

**Source of Funds:**

**Finance Comments:**

---

**Administrative Comments:**

---

**ATTACHMENTS:**

Description	Type
<input type="checkbox"/> FY21-22 P&R Retreat Presentation	Powerpoint Presentation



# Gainesville Parks & Recreation

## GAINESVILLE CITY COUNCIL RETREAT

FY22 BUDGET PRIORITIES  
THE STATION – GAINESVILLE ADMINISTRATION BUILDING



# ACCOMPLISHMENTS

## CURRENT DISCUSSION: ACCOMPLISHMENTS

### \$4.1 Million Invested in Major Capital Projects

\$1.95 Million Skate Park Opened

\$1 Million in City Park Renovations Completed

\$800K for Coop Property Acquisition

\$100,000 in New Park Signage



# CURRENT DISCUSSION: ACCOMPLISHMENTS

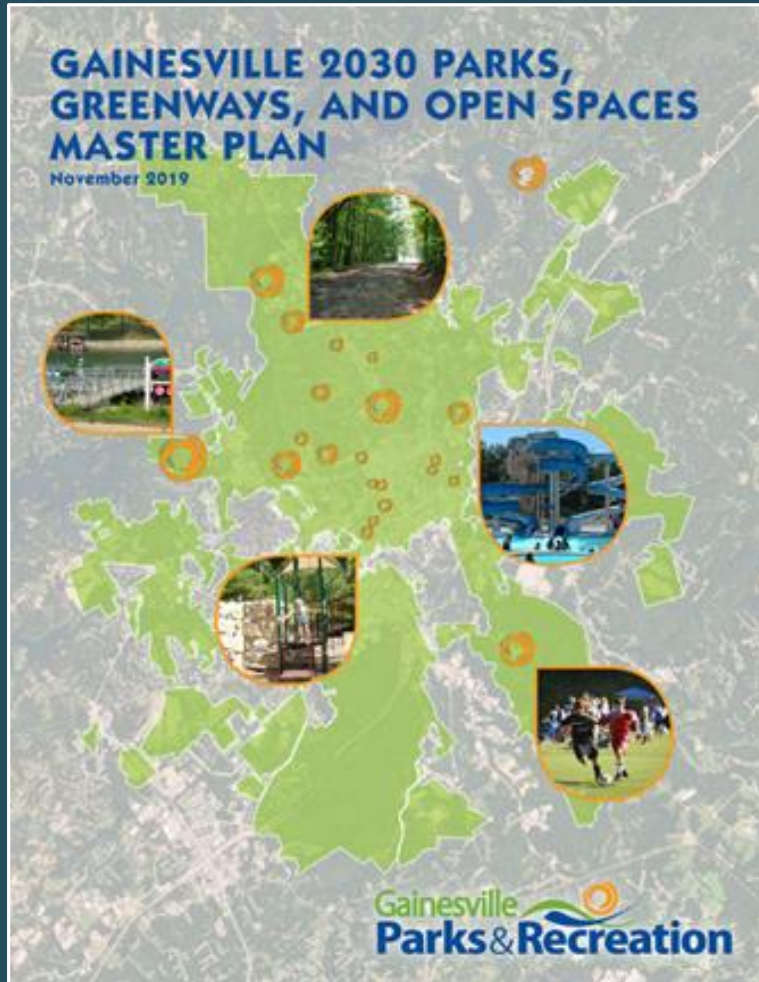

## CAPRA ACCREDITATION

REACCREDITED AGENCIES

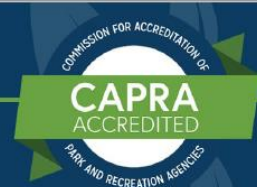

Gainesville Parks & Recreation Agency, Georgia



2020 Agency of the Year

## CURRENT DISCUSSION: ACCOMPLISHMENTS



# CURRENT DISCUSSION: ACCOMPLISHMENTS

Learn more about the 2021 Budget



The official site of  
Gainesville, Georgia

About Us Jobs Departments City Council Visitors Recreation Payments Contact Us

## Facility and Program Reopening Plan

home / recreation / covid know before you go

Updated August 6, 2020

### Important Reopening Information

As we continue to navigate the pandemic, Gainesville Parks & Recreation has reopened many of our facilities and programs.

We are making every effort to follow social distancing guidelines and appropriate reduced capacities in our facilities and programs. However, we cannot guarantee safety from exposure. If you are suffering any of the following symptoms or if you are anyone who has tested positive for COVID-19, please do not participate in our programs or enter our facilities at the moment.

**YOUR PARKS ARE OPEN!** Restrooms, pavilion rentals, courts, and playgrounds are open; please maintain social distancing and sanitize once per week.

**FRANCES MEADOWS IS OPEN!** Be advised, temperature checks are required and some activities have reduced capacities.

**FACILITY RENTALS ARE AVAILABLE!** Per Governor Kemp's orders; we are following social distancing guidelines and may be able to see if we can accommodate your event.

Operational changes vary greatly by facility but residents can expect to see additional security measures focused on safety. For more information for each facility.

[KNOW BEFORE YOU GO CROSS COUNTRY](#)

[KNOW BEFORE YOU GO FOOTBALL](#)

[KNOW BEFORE YOU GO CHEERLEADING](#)

[KNOW BEFORE YOU GO FRANCES MEADOWS CENTER](#)

[KNOW BEFORE YOU GO FACILITY RENTALS](#)

[KNOW BEFORE YOU GO LANIER POINT ATHLETIC COMPLEX](#)

[GAINESVILLE PARKS AND RECREATION EXPOSURE PROTOCOLS](#)

We look forward to seeing you!

Gainesville Parks and Recreation

**STAY SAFE. STAY ACTIVE. STAY HEALTHY.**





# CHALLENGES + OPPORTUNITIES

# FY19 ANNUAL SNAPSHOT

**MAINTAINS, OPERATES, PROTECTS.**  
**458+** ACRES OF LAND

- 21** PARKS
- 20** ATHLETIC FIELDS
- 14** MILES OF BLUEWAYS
- 11** MILES OF WALKING TRAILS
- 15** PUBLIC RESTROOMS
- 11** PLAYGROUNDS
- 3** BASKETBALL COURTS
- 2** AMPHITHEATERS

**95%** CUSTOMER SATISFACTION RATING

**\$17 MILLION** ECONOMIC IMPACT  
\*Includes Lake Lanier Olympic Park

**400+** Community Volunteers at a Fiscal Value of \$275K

**65%** of Revenue Generated from TAXES

**35%** of Revenue Generated from FEES  
National Average 29%

**70+** COMMUNITY PARTNERS COMBINING RESOURCES. SAVING MONEY.

**CAPRA ACCREDITED**  
COMMISSION FOR ACCREDITATION OF PARKS AND RECREATION SERVICES

**800,000** ANNUAL PARKS & FACILITY VISITORS

**OPERATES FIVE MAJOR COMMUNITY FACILITIES**  
GAINESVILLE CIVIC CENTER  
 FRANCES MEADOWS CENTER  
 LANIER POINT ATHLETIC CENTER  
 FAIR STREET NEIGHBORHOOD CENTER  
 MARTHA HOPE CABIN

**OVER 100K** CITIZENS IN ACTIVITIES THAT IMPACT HEALTH

**1,000+** RECREATION PROGRAMS OFFERED

**200** PART TIME & SEASONAL JOBS CREATED ANNUALLY

**MORE THAN 150K** RECREATION PARTICIPANTS

CHILDREN AT PLAY FUND  
 Making sure every child plays. More than 1,800 children served.

# FY20 ANNUAL SNAPSHOT

**161** STAFF TRAINING OPPORTUNITIES

**37** SPECIAL EVENTS OFFERED

**\$4 MILLION** ECONOMIC IMPACT  
\*Excludes Lake Lanier Olympic Park

**1,918** Participated in Youth Sports

**50,120** Frances Meadows Center Fitness Visits

**400+** Community Volunteers at a Fiscal Value of \$275,000+

**76** Local businesses invested

**70+** COMMUNITY PARTNERS COMBINING RESOURCES. SAVING MONEY.

**41k** in sponsorships

**800,000** ANNUAL PARKS & FACILITY VISITORS

**73 Kids Served**

**\$4.1m** CAPITAL IMPROVEMENTS

**1,000+** RECREATION PROGRAMS

**198** PART TIME & SEASONAL JOBS CREATED

**MORE THAN 100k** RECREATION PARTICIPANTS

COVID-19

Our biggest challenge comes down to **FUNDING.**



On average, Americans visit their local **park** and recreation facilities 27 times per year, or more than twice a month. Nineteen percent of survey respondents report between six and 10 annual **visits**, with another 16 percent between 11 and 20 **visits** within the past 12 months.

[www.nrpa.org](http://www.nrpa.org) › [globalassets](#) › [engagement-survey-report...](#) ⋮

# CURRENT DISCUSSION: CHALLENGES + OPPORTUNITIES

\$10 million in deferred maintenance and aging facilities and infrastructure



**BUDGET PRIORITY: INFRASTRUCTURE IMPROVEMENTS** | **STRATEGIC AREA: CITYWIDE**



# INITIATIVES

CURRENT DISCUSSION: INITIATIVES

Civic Center Renovations



FY21 SPLOST PROJECT

# FY21 SPLOST PROJECT MIDLAND WYE

**LEGEND**

- CONCRETE FINISH
- HEAVY DUTY ASPHALT FINISH
- PLATFORM SURFACE
- CONCRETE REINFORCE FINISH
- HEAVY DUTY CONCRETE FINISH
- BENCH
- PAVING COURT
- TABLE
- TRAFFIC SIGN

**GENERAL NOTES:**

1. ALL PROPOSED DIMENSIONS SHOWN TO SHOW THE GEOMETRIC LAYOUT OF THE PROPOSED FACILITY AND ARE SUBJECT TO THE FIELD SURVEY. ALL PROPOSED DIMENSIONS ARE TO BE USED TO LOCATE THE CENTERLINE OF THE PROPOSED BUILDING LOCATION AND SHALL BE THE CENTERLINE OF THE BUILDING CORNER. ALL CORNERS ARE SHOWN AT THE FACE OF CURB.
2. CONTRACTOR SHALL VERIFY DIMENSIONS OF ANY DIMENSIONS BETWEEN THE EXISTING CONDITIONS IN THE FIELD AND THE ALIGNED BROWN ON THE PLANS BEFORE PROCEEDING WITH ANY CONSTRUCTION.
3. CONTRACTOR IS RESPONSIBLE FOR CORRECTING ANY AND ALL DISCREPANCIES AND VARIATIONS OF ALL TYPES BETWEEN PROPOSED AND EXISTING CONDITIONS, CURB AND SLOPE, SIDEWALKS, WALKS, AND UTILITIES.

**SITE NOTES:**

1. TRACT IS ZONED AS LOW DENSITY OVERLAY ZONE (LD-1) AND IS SUBJECT TO THE CITY OF GAINESVILLE'S ZONING ORDINANCE AND ALL APPLICABLE REGULATIONS.
2. SEE ARCHITECTURAL PLANS FOR BUILDING FLOOR PLAN, EXTERIOR DOOR LOCATIONS, WALKWAY LAYOUTS, AND OTHER ARCHITECTURAL DETAILS.
3. NO CERTIFICATE OF OCCUPANCY WILL BE ISSUED UNTIL ALL SITE IMPROVEMENTS HAVE BEEN COMPLETED ON THE SITE.
4. NEW INTERIM LIGHTING FACILITIES SHALL BE SO ARRANGED THAT THE SOURCE OF ANY LIGHT IS CONSIDERED FROM THE PUBLIC VIEW AND DOES NOT INTERFERE WITH TRAFFIC (SEE PHOTOGRAPHIC PLAN IN ARCH. PLANS).
5. ALL SIGNAGE, TRAFFIC SIGNS, AND LIGHT FIXTURES SHALL BE COMPLY COMPLIANT WITH ALL APPLICABLE REGULATIONS PRIOR TO COMMENCEMENT OF ANY AND ALL CONSTRUCTION.
6. NO OUTSIDE STORAGE IS PROPOSED. THIS INCLUDES SUPPLIES, VEHICLES, EQUIPMENT, REFRIGERATORS, ETC.
7. SIGNAGE LOCATION, NUMBER, AND SIZE ARE NOT APPROVED UNDER THE SIGNAGE PERMIT. A SEPARATE PERMIT IS REQUIRED FOR ON-SITE SIGNAGE.
8. ALL SIGNAGE MUST BE SUBJECT TO THE CITY OF GAINESVILLE'S SIGNAGE PERMIT REGULATIONS AND ALL APPLICABLE REGULATIONS.
9. ALL CONSTRUCTION RELATED PERMITS DURING THE CONSTRUCTION PHASE OF THIS PROJECT ARE THE RESPONSIBILITY OF THE OWNER. HOWEVER, A CONTRACTOR/OWNER CAN DO PERMITS WITH KEY PERMITS APPROVED.
10. ALL SPECIAL SIGNAGE PERMITS AND TRAFFIC PROTECTION MEASURES SHALL BE REVIEWED PRIOR TO ANY SIGNING.
11. MAINTAIN CUT OR FILL SLOPES.
12. CITY OF GAINESVILLE ACCEPTS NO RESPONSIBILITY FOR THE AMERICAN INFRASTRUCTURE ACT (2012) REQUIREMENTS FOR INFRASTRUCTURE. THE OWNER/DEVELOPER IS SOLELY RESPONSIBLE FOR COMPLIANCE FOR SAID ACT.
13. 24 HOUR CONTACT: 800.877.8888
14. CONTRACTOR SHALL COORDINATE WITH THE UTILITIES AND ALL APPLICABLE REGULATIONS AND OBTAIN ALL NECESSARY PERMITS PRIOR TO COMMENCEMENT OF ANY AND ALL CONSTRUCTION. THE CONTRACTOR SHALL BE RESPONSIBLE FOR OBTAINING ALL NECESSARY PERMITS PRIOR TO COMMENCEMENT OF ANY AND ALL CONSTRUCTION.
15. CONTRACTOR SHALL COORDINATE WITH THE UTILITIES AND ALL APPLICABLE REGULATIONS AND OBTAIN ALL NECESSARY PERMITS PRIOR TO COMMENCEMENT OF ANY AND ALL CONSTRUCTION.

**GEORGIA 811**  
Utilities Protection Center, Inc.  
Keep what's below.  
Call before you dig.

**DESIGNER:** FORESITE group  
1700 S. W. 10th St., Suite 100  
Tallahassee, FL 32309  
Phone: 904.633.1111  
Fax: 904.633.1112  
www.foresitegroup.com

**DEVELOPER:** Gainesville Parks & Recreation Agency  
300 GUNN STREET  
GAINESVILLE, FL 32601  
954-357-7000  
CONTACT: MR. MICHAEL GRANAM

**PROJECT:** GAINESVILLE GREENWAY MIDLAND WYE  
548 GLENWOOD DRIVE  
GAINESVILLE, FL 32601  
PARCEL: 4010.000000, 4011.000000

**SCALE:**

# DEFERRED MAINTENANCE PROJECTS



LED Field Lighting @ Lanier Point



Playground @ Longwood



Scorer Stands @ Candler Fields

# FY22 SPLOST PROJECT



Midland Greenway Phase II



Greenway Lighting – RCG & MG



Disc Golf Course @ Wessell

# MASTER PLAN RECOMMENDED AMENITIES



Restroom @ Riverside Park

# CURRENT DISCUSSION: INITIATIVES



**CITY OF SANDSPRING NOTES:**

1. THE CITY OF SANDSPRING HAS REVIEWED THE PROJECT AND HAS APPROVED THE PROJECT FOR CONSTRUCTION.
2. THE CITY OF SANDSPRING HAS REVIEWED THE PROJECT AND HAS APPROVED THE PROJECT FOR CONSTRUCTION.
3. THE CITY OF SANDSPRING HAS REVIEWED THE PROJECT AND HAS APPROVED THE PROJECT FOR CONSTRUCTION.
4. THE CITY OF SANDSPRING HAS REVIEWED THE PROJECT AND HAS APPROVED THE PROJECT FOR CONSTRUCTION.
5. THE CITY OF SANDSPRING HAS REVIEWED THE PROJECT AND HAS APPROVED THE PROJECT FOR CONSTRUCTION.
6. THE CITY OF SANDSPRING HAS REVIEWED THE PROJECT AND HAS APPROVED THE PROJECT FOR CONSTRUCTION.
7. THE CITY OF SANDSPRING HAS REVIEWED THE PROJECT AND HAS APPROVED THE PROJECT FOR CONSTRUCTION.
8. THE CITY OF SANDSPRING HAS REVIEWED THE PROJECT AND HAS APPROVED THE PROJECT FOR CONSTRUCTION.
9. THE CITY OF SANDSPRING HAS REVIEWED THE PROJECT AND HAS APPROVED THE PROJECT FOR CONSTRUCTION.
10. THE CITY OF SANDSPRING HAS REVIEWED THE PROJECT AND HAS APPROVED THE PROJECT FOR CONSTRUCTION.
11. THE CITY OF SANDSPRING HAS REVIEWED THE PROJECT AND HAS APPROVED THE PROJECT FOR CONSTRUCTION.
12. THE CITY OF SANDSPRING HAS REVIEWED THE PROJECT AND HAS APPROVED THE PROJECT FOR CONSTRUCTION.
13. THE CITY OF SANDSPRING HAS REVIEWED THE PROJECT AND HAS APPROVED THE PROJECT FOR CONSTRUCTION.
14. THE CITY OF SANDSPRING HAS REVIEWED THE PROJECT AND HAS APPROVED THE PROJECT FOR CONSTRUCTION.
15. THE CITY OF SANDSPRING HAS REVIEWED THE PROJECT AND HAS APPROVED THE PROJECT FOR CONSTRUCTION.
16. THE CITY OF SANDSPRING HAS REVIEWED THE PROJECT AND HAS APPROVED THE PROJECT FOR CONSTRUCTION.
17. THE CITY OF SANDSPRING HAS REVIEWED THE PROJECT AND HAS APPROVED THE PROJECT FOR CONSTRUCTION.
18. THE CITY OF SANDSPRING HAS REVIEWED THE PROJECT AND HAS APPROVED THE PROJECT FOR CONSTRUCTION.
19. THE CITY OF SANDSPRING HAS REVIEWED THE PROJECT AND HAS APPROVED THE PROJECT FOR CONSTRUCTION.
20. THE CITY OF SANDSPRING HAS REVIEWED THE PROJECT AND HAS APPROVED THE PROJECT FOR CONSTRUCTION.

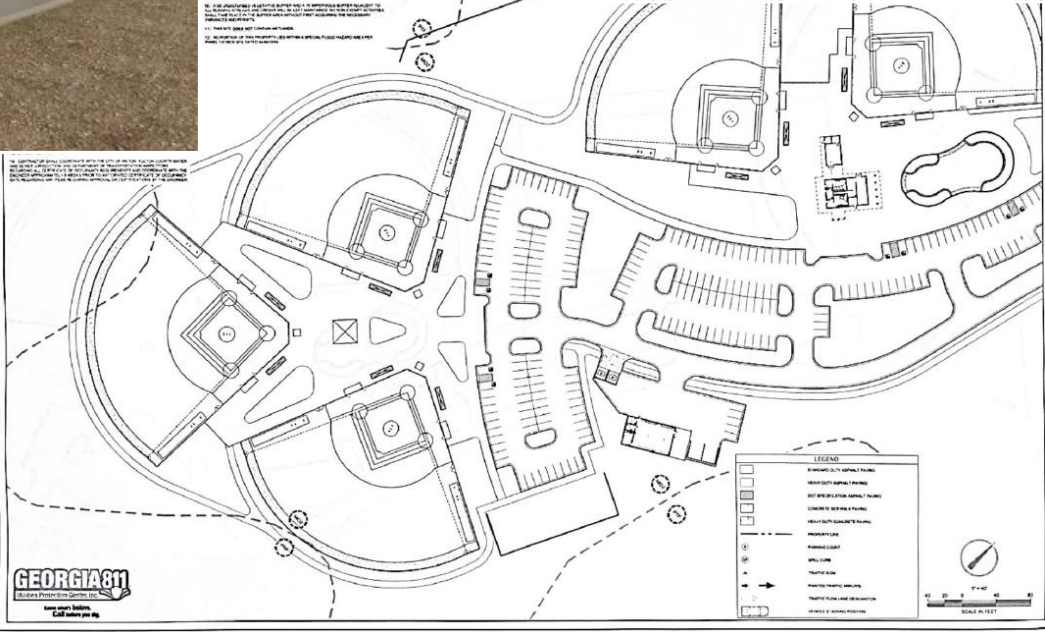

# THE COOP

# PROGRAM INITIATIVES

**SKATEBOARD LESSONS**

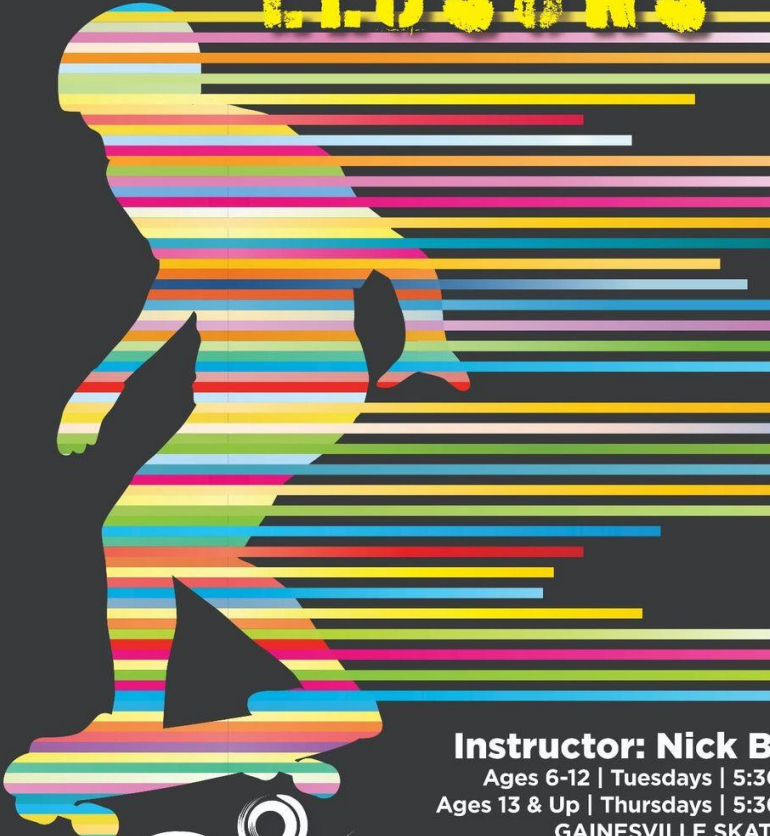

**Instructor: Nick B**  
 Ages 6-12 | Tuesdays | 5:30-6:30  
 Ages 13 & Up | Thursdays | 5:30-6:30  
 GAINESVILLE SKATE

**FIND OUT MORE**  
[gainesville.org/skate](http://gainesville.org/skate)  
 770.531.2680

**Gainesville Parks & Recreation**

**READY FITNESS**  
 EQUIPMENT • DESIGN • SERVICE

**READY FOR BETTER?**  
 Attention to detail. Quality Control. Commitment to a relationship-driven process.



**RECOMMENDATIONS & PROPOSAL**

PREPARED EXCLUSIVELY FOR:  
 Frances Meadows Center-rev 4 - Michael Waters

**SPORTS CAMP**



# CURRENT DISCUSSION: INITIATIVES

NAME	PARCEL ID	ACRE	OWNER	ADDRESS	\$\$\$
White Sulfer #1	15020A 000012A	33.93	Danji, LLC	2894 White Sulfer Rd	\$ 407,430.00
White Sulfer #2	15020A 000012	65.21	Danji, LLC	2862 White Sulfer Rd	\$ 501,200.00
White Sulfer #3	15020 000009	30.82	Ramsey, William O Jr	2871 Ramsey Rd	\$ 269,700.00
Eberhart	15022 000001B	86.53	Gainesville Vision LLC	0 Eberhart Cemetary Rd	\$ 247,000.00
Athens Hwy Island	15023 000041	52.11	Hall Co	0 Athens Hwy	\$ 370,000.00
Athens Hwy Island - Access	15023 000008	38.17	Jones, Warren T	0 Athens Hwy	\$ 210,200.00
Floyd Rd #1	15022 000034	38.93	Gainesville Vision LLC	2544 Floyd Rd SE	\$ 215,000.00
Floyd Rd #2	15022 000004	97.98	Gainesville Vision LLC	0 Lenox Dr SE	\$ 287,900.00
Elchahal Eberhart #1	15022 000001	73.85	Elchahal Property Holdings LLC	3490 Eberhart Cemetary Rd	\$ 472,800.00
Elchahal Eberhart #2	15022 000001A	60	Elchahal Property Holdings LLC	0 Gaines Mill Rd SW	\$ 408,000.00
Palmour #1	15035 000027	58.47	City of Gainesville	0 Atlanta Hwy SW	\$ 210,200.00
Palmour #2	15036 000013	1027.2	Gainesville, Area Park	2510 Atlanta Hwy SW	\$ 13,182,330.00
Palmour #3	15035 000028	73.64	Gainesville, Area Park	0 Palmour PI SW	\$ 1,026,700.00
Gilleland Ext	15036 000013A	80.98	Lance, Alan W.	0 Poplar Springs Rd	\$ 1,059,700.00
Lee Land Rd	15031 000164	64.01	Gainesville, City of	0 Lee Land Rd SW	\$ 985,700.00
2955 Gillsville Hwy	15016 000030A	347.23	Pacific Crest Mgmt LLC	2955 Gillsville Hwy	\$ 1,015,000.00
2955 Gillsville Hwy - Access	15016 000042	51.53	Canada, Steve	3226 Gaines Mill Rd	\$ 342,700.00
2825 Gaines Mill Rd	15022 000008	65.32	Lisnavy Properties LLC	2825 Gaines Mill Rd	\$ 308,700.00
2901 Gaines Mill Rd	15022 000009	97.81	Elchahal Property Holdings LLC	2901 Gaines Mill Rd	\$ 590,500.00
Norris Rd	15020B 000003	98.59	Lisnavy Properties LLC	3742 Norris Rd	\$ 422,000.00
2937 Ramsey Rd	15020 000041	51.74	985 Partners II LLC	2937 Ramsey Rd	\$ 1,347,400.00
3104 Athens Hwy	15024 000227	68.96	Shirley P. Souther Irrevocable Credit Shelt	3104 Athens Hwy	\$ 440,800.00
Limestone #1	00082 003001	8.96	Limestone Greenway LLC	0 Limestone Pkwy	\$ 1,713,400.00
Limestone #2	01083 002003A	38.96	McEver Road Properties LLC	0 Beverly Rd NE	\$ 2,034,000.00
Allen Creek+	15023 000167	1504.87	Gainesville City of	1701 Fulenwider Rd SW	
Old Cornelia Hwy	15033 000011	838.52	Gainesville Vision LLC	3490 Old Cornelia Hwy SE	\$ 2,482,001.00
River Forks Park		111.16	ACACE		
Clarks Bridge Park		32.21	ACACE		
Duckett Mill Park		87.02	ACACE		
Laurel Park		124.22	ACACE		
Mountain View Park		54.98	ACACE		
Robinson park		47.55	ACACE		
Bolding Mill Park		75.49	ACACE		
Little Hall Park		39.31	ACACE		
Sardis Creek Park		30.02	ACACE		
Lanier Point Park		79.22	ACACE		

**LAND FEASIBILITY STUDY**

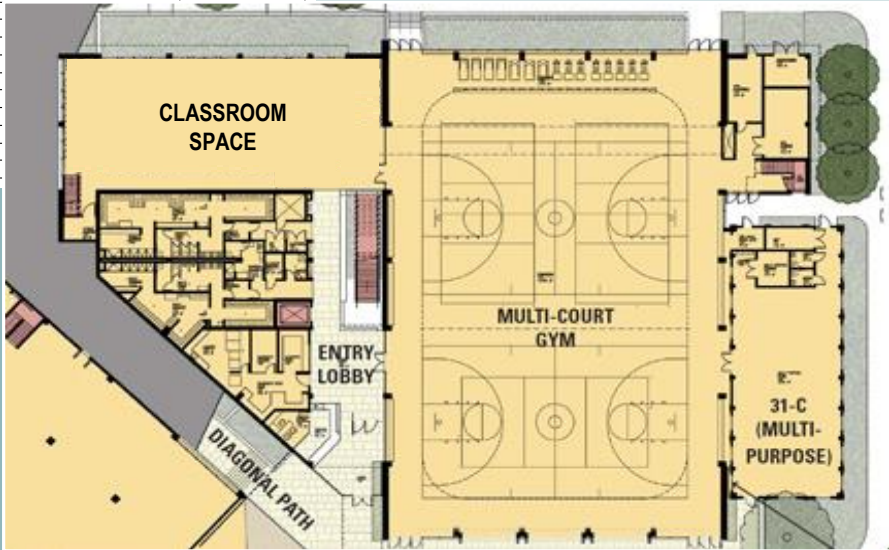
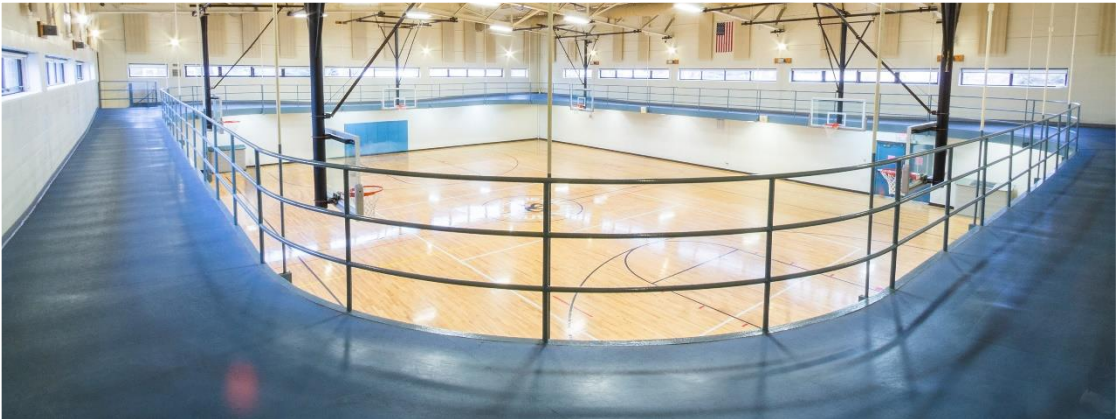

# PROPOSED RECREATION CENTER

CURRENT DISCUSSION: INITIATIVES

BUDGET  
SUMMARY  
DRAFT

<b>FY2022 PROPOSED</b>		<b>PARKS &amp; RECREATION BUDGET SUMMARY</b>		
	Actual FY20 (.75 Mills)	Revised FY21 (.75 Mills)	<b>PROPOSED FY22 (.896 Mills)</b>	Variance Change From FY21 Rev.
<b>REVENUES</b>				
<i>Non-Departmental</i>				
Property Taxes	3,855,947.91	4,064,427.00	<b>4,800,000.00</b>	735,573.00
Interest	82,116.08	26,250.00	<b>52,500.00</b>	26,250.00
Parks Development Fund	3,123.23	500.00	<b>2,500.00</b>	2,000.00
Miscellaneous & Private Contributions	1,415.16	2,000.00	<b>2,000.00</b>	-
Other financing sources/transfers in	107,253.42	-	-	-
P&R Capital Project Closeout				-
Intergovernmental	200,000.00		-	-
Transfer from General Fund				-
Transfer from Hotel/Motel Fund				-
Sale of Assets	48.79	-	-	-
<i>Departmental</i>				
Charges for Services				
Recreation Services	90,410.90	137,400.00	<b>137,400.00</b>	-
Allen Creek Soccer Complex	286.38	13,300.00	<b>5,500.00</b>	(7,800.00)
Civic Center/Facility Services	251,268.98	258,350.00	<b>251,500.00</b>	(6,850.00)
Frances Meadows Center	644,684.29	897,500.00	<b>908,000.00</b>	10,500.00
Youth Sports Booster Club	69,701.95	107,250.00	<b>102,800.00</b>	(4,450.00)
Lanier Point Athletic Complex	90,744.39	129,101.00	<b>134,400.00</b>	5,299.00
<b>TOTAL REVENUES</b>	<b>5,397,001.48</b>	<b>5,636,078.00</b>	<b>6,396,600.00</b>	<b>760,522.00</b>
<b>EXPENDITURES</b>				
<i>Non-Departmental</i>				
Indirect Costs Allocation	50,000.04	50,000.00	<b>50,000.00</b>	-
Other Financial Uses/Capital Outlay	345,000.00	0.00	<b>250,000.00</b>	250,000.00
Deferred Maintenance			<b>500,000.00</b>	
Contributions to other Agencies	280,571.00	150,000.00	<b>0.00</b>	(150,000.00)
<i>Departmental</i>				
Maintenance Shop	107,009.16	137,342.00	<b>142,268.00</b>	4,926.00
Recreation Division	288,846.52	422,236.00	<b>436,494.00</b>	14,258.00
ACSC @ 18%	42,982.00	50,852.00	<b>52,796.00</b>	1,944.00
Facility Services	523,706.77	624,395.00	<b>631,080.00</b>	6,685.00
Frances Meadows Center	1,421,059.84	1,830,858.00	<b>1,842,049.00</b>	11,191.00
YSBC	164,033.50	186,703.00	<b>191,274.00</b>	4,571.00
Parks Division	911,348.86	1,132,514.00	<b>1,197,435.00</b>	64,921.00
Lanier Point Park	190,366.00	235,207.00	<b>234,273.00</b>	(934.00)
Administrative Division	765,442.30	815,971.00	<b>868,931.00</b>	52,960.00
<b>TOTAL EXPENDITURES</b>	<b>5,090,365.99</b>	<b>5,636,078.00</b>	<b>6,396,600.00</b>	<b>260,522.00</b>
Excess Revenue Over Expenses:	306,635.49	0.00	<b>0.00</b>	<b>500,000.00</b>

Notes: 1 - SPLOST Funded Projects not show in this summary



QUESTIONS?  
COMMENTS?  
CONCERNS?

**GAINESVILLE  
CITY COUNCIL  
RETREAT**

**2021-22 BUDGET PRIORITIES  
THE STATION – GAINESVILLE ADMINISTRATION BUILDING**