

Council Retreat Agenda

- **City Vision / Mission**
- **Financial Update**
- **Fire**
- **Golf**
- **Community Service Center**
- **Tourism / Public Relations**
- **Police**
- **Administrative Services**
- **Parks & Recreation**
- **Recap & Discussion**
- **Executive Session**
- **Closing Remarks**
- **Adjournment**

Final: Wednesday, March 11, 2020, 1:30 PM



Vision Mission Values

2020 BUDGET PRIORITIES
FAIR STREET NEIGHBORHOOD CENTER

- ▶ City Vision/Mission (8:30 – 9:00)
- ▶ Financial Update (9:00 – 9:45)
- ▶ Break (9:45 – 10:00)
- ▶ Fire (10:00 – 10:30)
- ▶ Golf (10:30 – 11:00)
- ▶ CSC (11:00 – 11:30)
- ▶ Tourism / Public Relations (11:30 -12:00)
- ▶ Lunch (12:00 – 12:45)
Morning Recap
- ▶ Police (12:45 – 1:15)
- ▶ Administrative Services (1:15 – 1:45)
- ▶ Break (1:45- 2:00)
- ▶ Park & Rec (2:00 – 2:30)
- ▶ Afternoon Recap & Discussion (2:30 – until)

RETREAT AGENDA

2019 COUNCIL RETREAT RECAP



Traffic Congestion Relief



Infrastructure –Paving, Water, Sewer & Stormwater



Housing & Growth – Downtown Projects, Housing Programs, Land Bank



Employee Compensation & Benefits



Public Safety – Park Hill Focus, Impact Fees for Public Safety

FY20 CAPITAL IMPROVEMENTS PLAN

- Roadway Improvements/Resurfacing
- Intelligent Transportation System Network
- Sidewalks / Trails
 - Highland To Islands – Palmour Drive Connection
- Equipment Replacement
 - Brine Maker & Truck
 - Police Cars
 - Packer Trucks
 - Street Sweeper
 - Knuckle Boom Lift Truck
- Skate Park
- Police & Fire Radio Upgrades
- Library Parking Deck Design
- Community Service Center Renovations
- Administration Building/Campus Renovations
 - Final Phase
- Park Hill Drive Neighborhood Plan
- Lake Lanier Olympic Park Improvements
- Stormwater Infrastructure
- Athens Highway Sewer Extension

VISION, MISSION, VALUES

Vision

- Gainesville is committed to being an innovative city, providing a close-knit community feel in which to live, work and play.

Mission

- The mission of the City of Gainesville is to enrich the community of Gainesville by practicing good stewardship of resources and providing innovative and exemplary services for all people.

Values

- Excellence
- Honesty
- Open Communication
- Commitment
- Stewardship
- Trust
- Accountability
- Leadership
- Quality of Life

GOAL DEVELOPMENT PROCESS

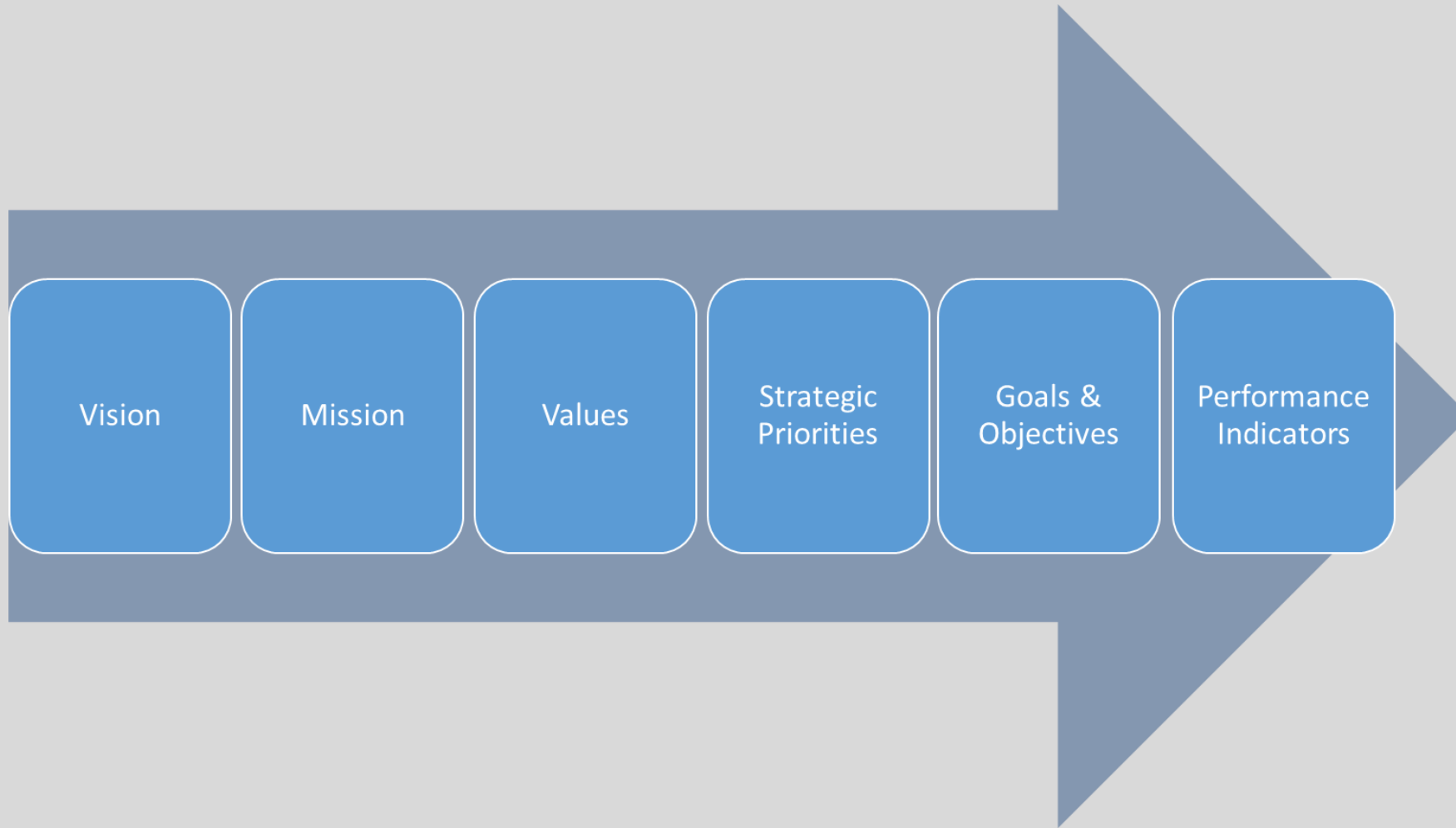

FOCUS ON STRATEGIC PRIORITIES & CORE SERVICES

5 Strategic Priority Categories & Sectors

- Categories
 - Economic Development
 - Infrastructure Improvements
 - Internal Operations
 - Leisure Services
 - Quality of Life
- Sectors
 - Downtown/Midtown
 - South
 - East
 - North
 - West

Think About Your Department's Core Services & How They Relate To These Priorities

STRATEGIC PRIORITIES

ECONOMIC DEVELOPMENT

- **Community Development – promote Gainesville as a regional HUB**
- **Support the Implementation of the Downtown Master Plan**
- **New Business Development / Existing Business Support**
- **Encourage/Facilitate private development and redevelopment**
- **Support Economic Development along Employment & Retail Corridors**
- **Maintain ISO rating at Fire Department**
- **Focus on increasing jobs through continued investment in the identification of the next industrial park**
- **Foster revitalization of blighted commercial corridors**

STRATEGIC PRIORITIES



INTERNAL OPERATIONS

- Focus on the Implementation of the I/T Master Plan
- Review employee salaries and benefits to evaluate and improve, as needed, to employ and retain a top quality workforce
- Encourage departments to work collectively
- Develop a Project Management System to expedite capital project initiation and completion
- Increase public awareness of City projects, operations and financial position by using multiple methods and outlets
- Review internal process to ensure effectiveness in delivery and efficiency of process to reach goals
- Involve more young people in government

STRATEGIC PRIORITIES

LEISURE SERVICES

- Direct more attention toward services for senior citizens and disabled programs
- Continued support of the Lake Lanier Olympic Park
- Continued commitment to maintain Chattahoochee Golf Club as one of the top Municipal courses in Georgia
- Work with Hall County to improve library services in the downtown area
- Enhanced recreational services for youth (baseball/softball fields)
- Continue the development and expansion of the Highlands to Islands Trail
- Incorporate “Urban Leisure” into downtown, midtown and public spaces through the development and/or conversion of plazas and alleyways into desirable and useable space

STRATEGIC PRIORITIES

INFRASTRUCTURE IMPROVEMENTS

- **Improve Traffic Flow Along Green Street/Oak Tree Drive**
- **Address traffic flow along Major Corridors**
 - Jesse Jewell Pkwy
 - Dawsonville Hwy
 - E.E. Butler Pkwy
- **Resurfacing of City Streets**
- **Implementation of the Transportation Master Plan**
- **Improved Sidewalk Network**
- **Equip traffic signals with fiber and video detection for connection to the City's Intelligent Transportation System**
- **Make strategic local improvements to upgrade the City's transportation network**
- **Resolve Cedar Creek/North Oconee issue with County**

STRATEGIC PRIORITIES

QUALITY OF LIFE

- Signage
 - “Welcome to Gainesville” signs at entrances to the City
 - Way finding signage
- Beautification of public areas including right of ways
 - Landscaping Plan for City corridors and downtown square
 - Enhance landscaping on Midtown Greenway
 - Beautification of gateways
 - Incorporate Art into public spaces and/or private development
- Focus on Initiatives that remove commercial and residential blight
 - Code Enforcement
 - ULDC Updates
 - Support Housing Authority & Housing Programs
 - Land Bank
- Code Enforcement / Neighborhood Protection
- Improve the 129 South entrance to Gainesville
(infrastructure, clean up, business development)
- Streetscapes into and out of Square along Washington and Bradford Streets

STRATEGIC PRIORITIES

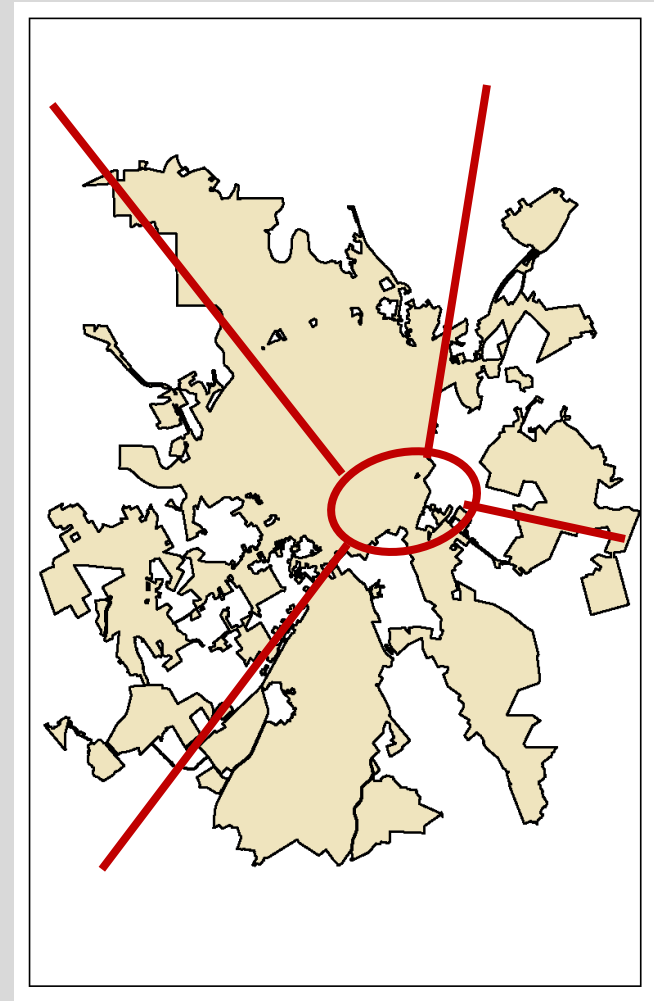

FOCUS ON STRATEGIC PRIORITIES & CORE SERVICES

- New Initiatives for FY21
- Where Does Our Focus Need To Be?

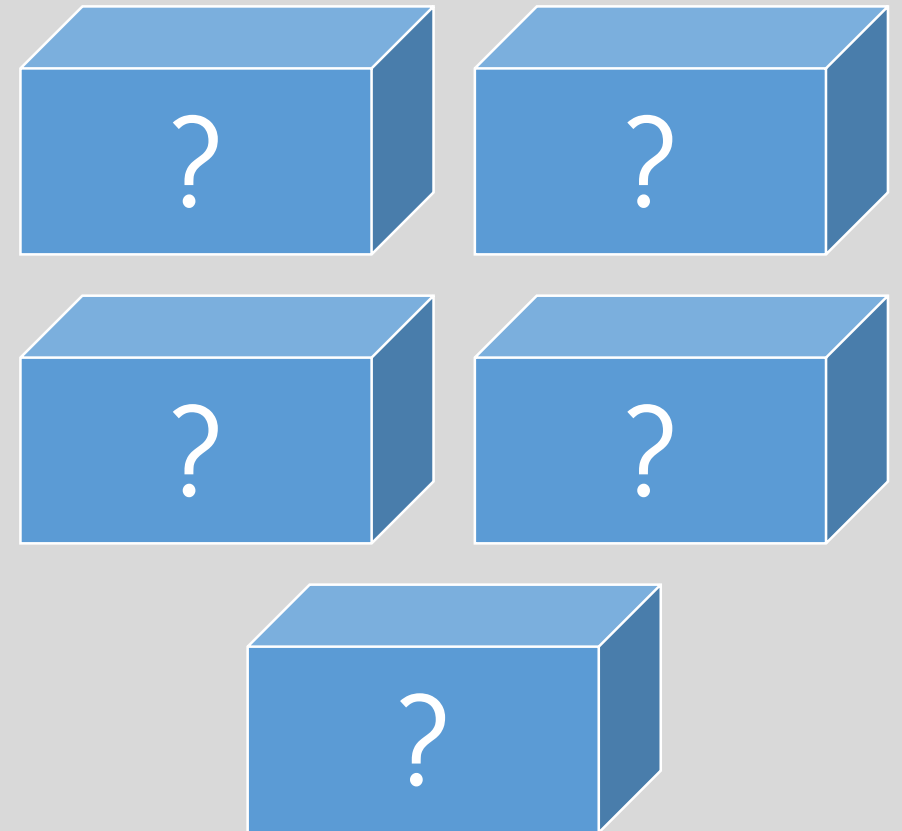



CITY OF
GAINESVILLE





Financial Services

2020 BUDGET PRIORITIES
FAIR STREET NEIGHBORHOOD CENTER

FINANCIAL UPDATE

General Fund Property Tax Revenue

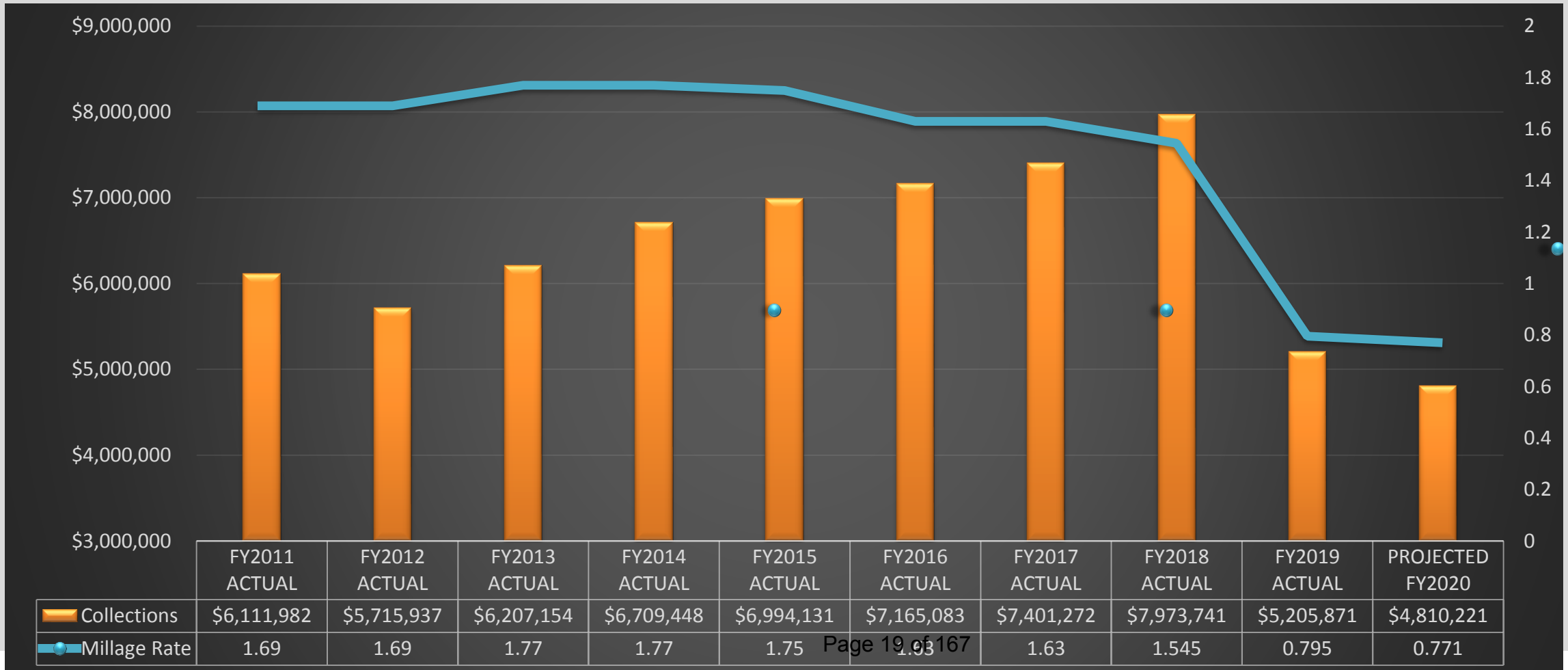

FINANCIAL UPDATE

Budget Priority:

Internal Operations

Strategic Area: Citywide

Local Option Sales Tax Revenue

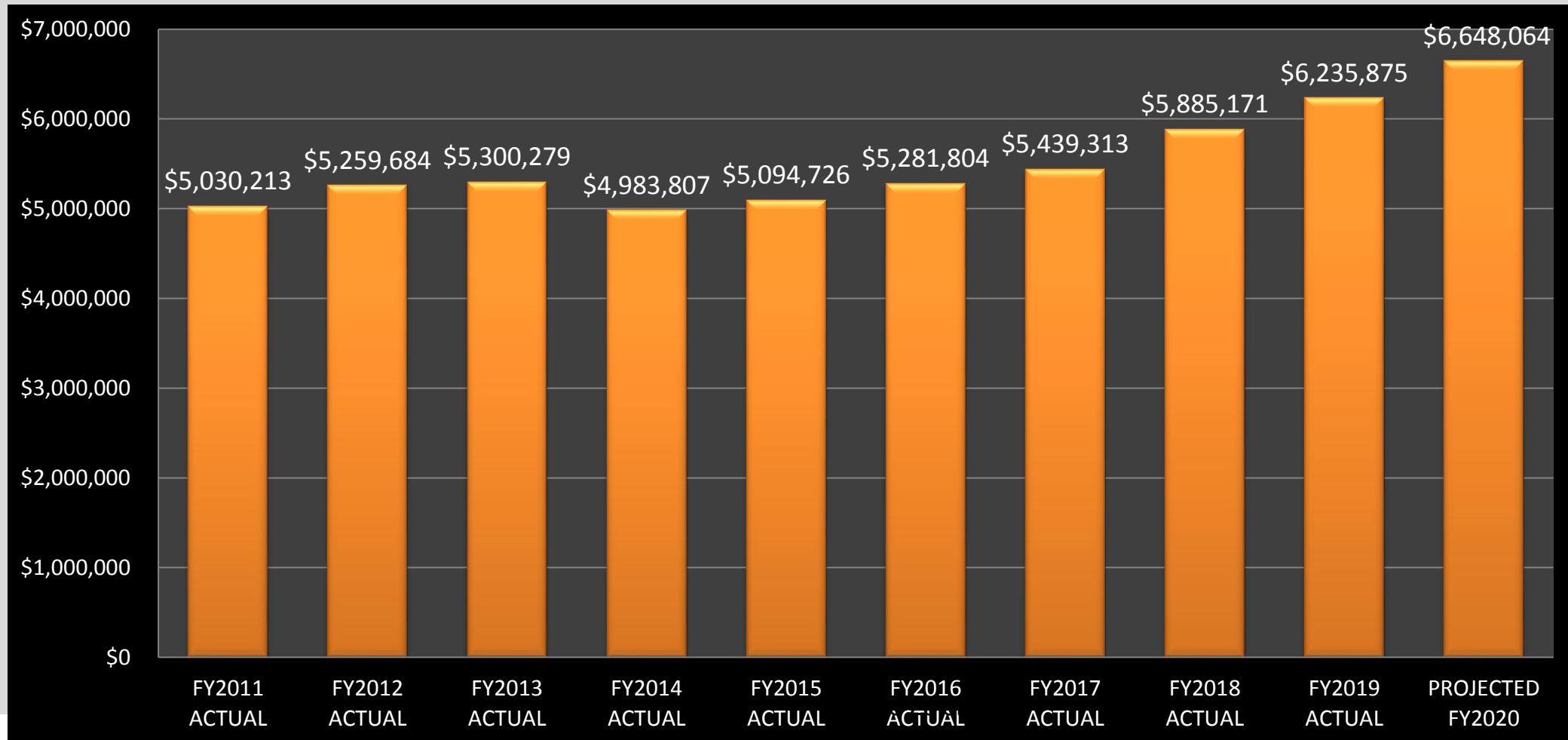

FINANCIAL UPDATE

Budget Priority:

Internal Operations

Strategic Area: Citywide

Franchise Fee Revenue

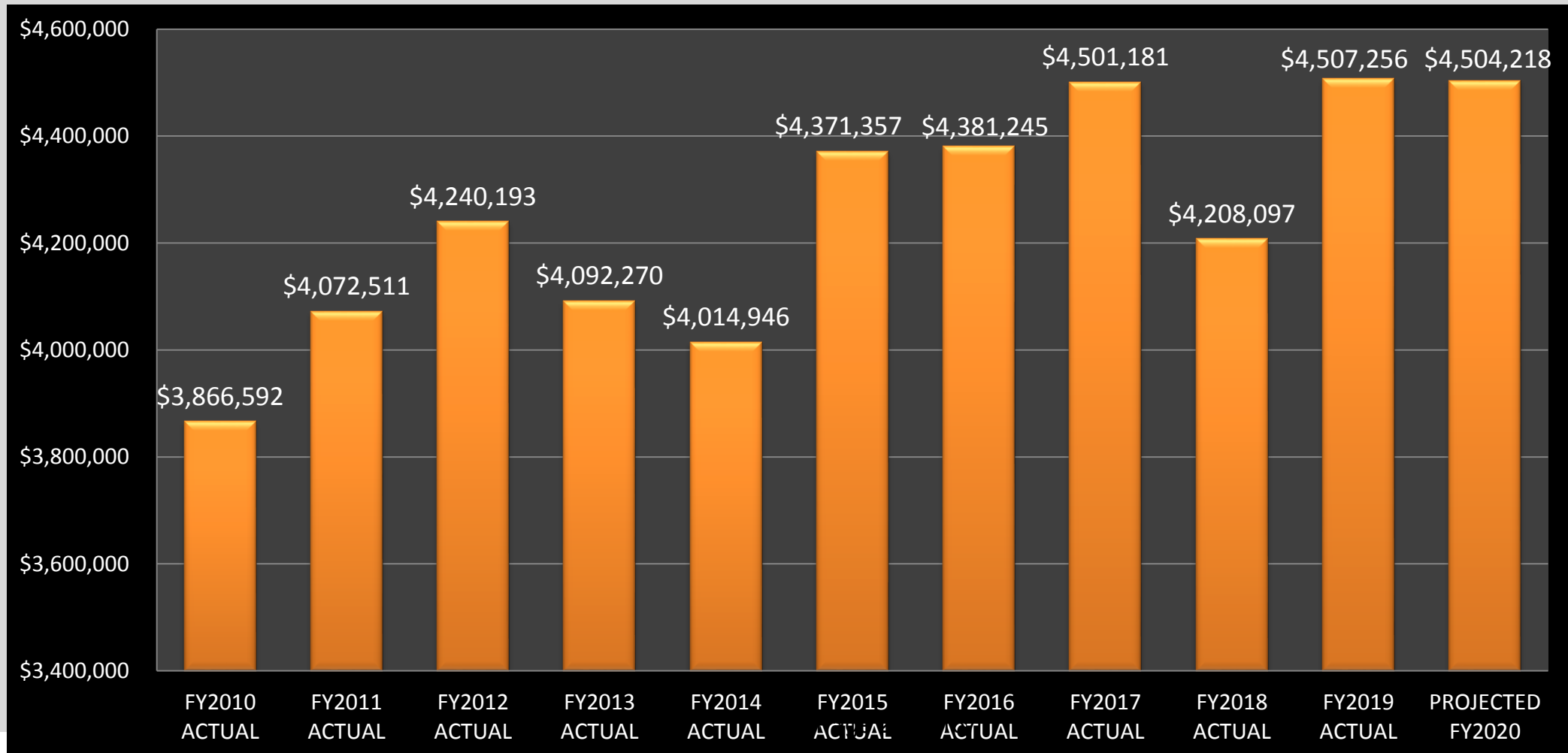

FINANCIAL UPDATE

Budget Priority:
Internal Operations
Strategic Area: **Citywide**

Fines and Forfeiture Revenue

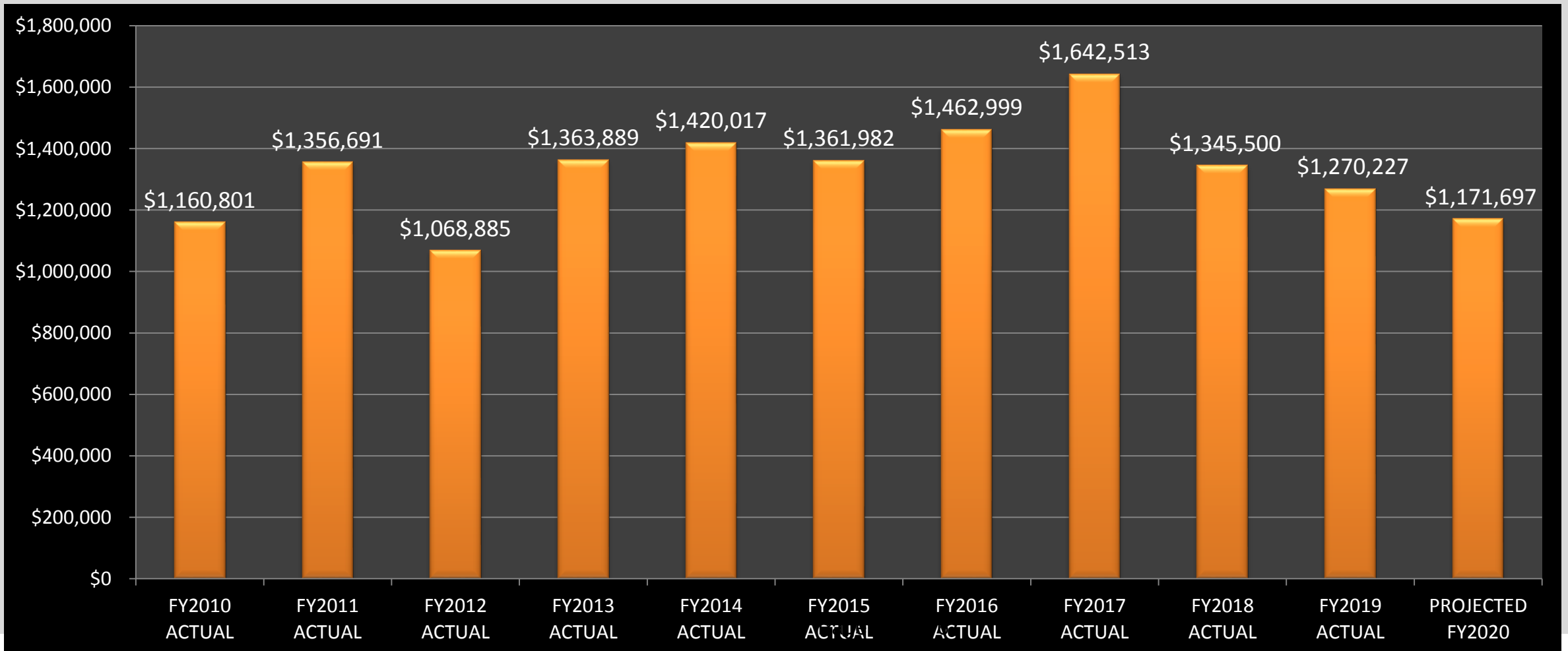

FINANCIAL UPDATE

Budget Priority:

Internal Operations

Strategic Area: Citywide

Permits and Zoning Fee Revenue

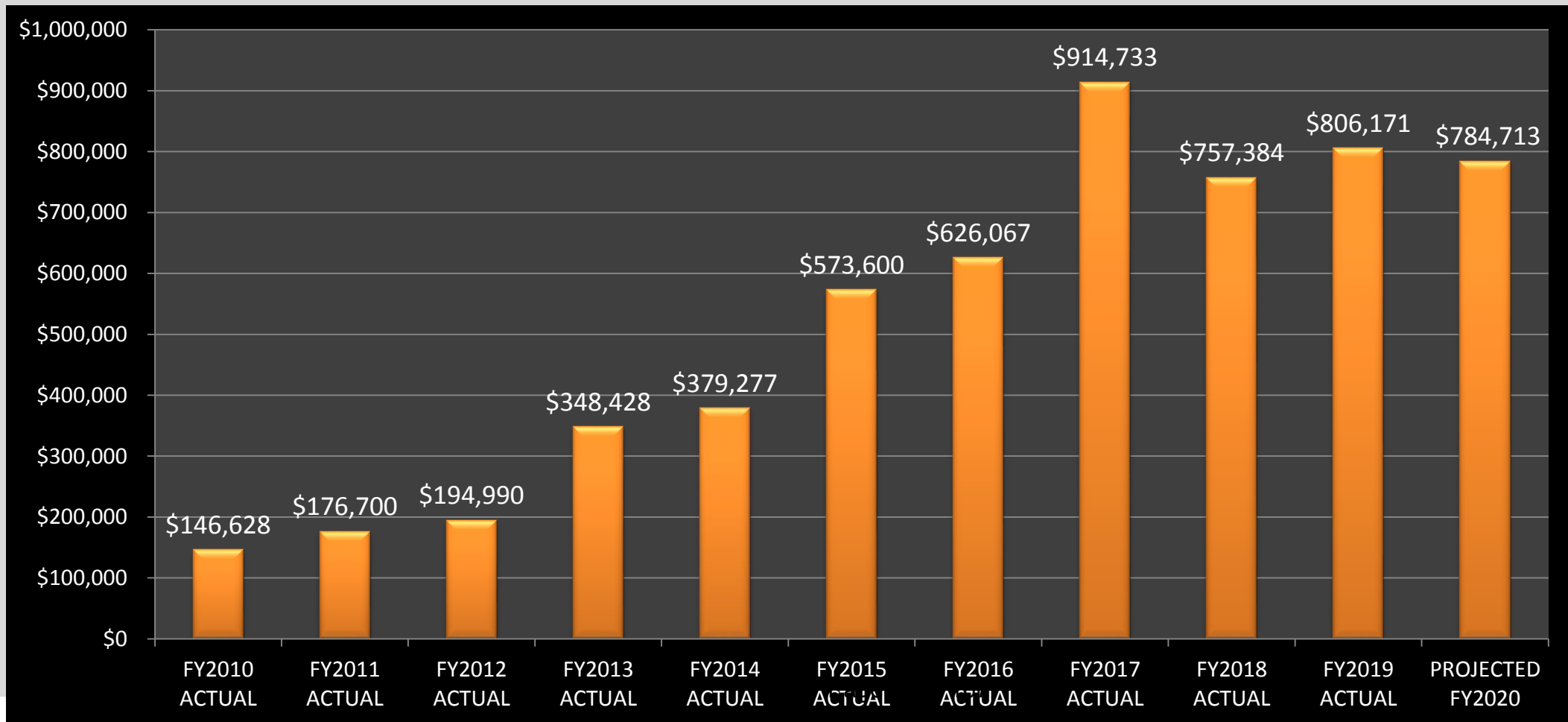

FINANCIAL UPDATE

Budget Priority:

Internal Operations

Strategic Area: Citywide

Occupational Tax Revenue

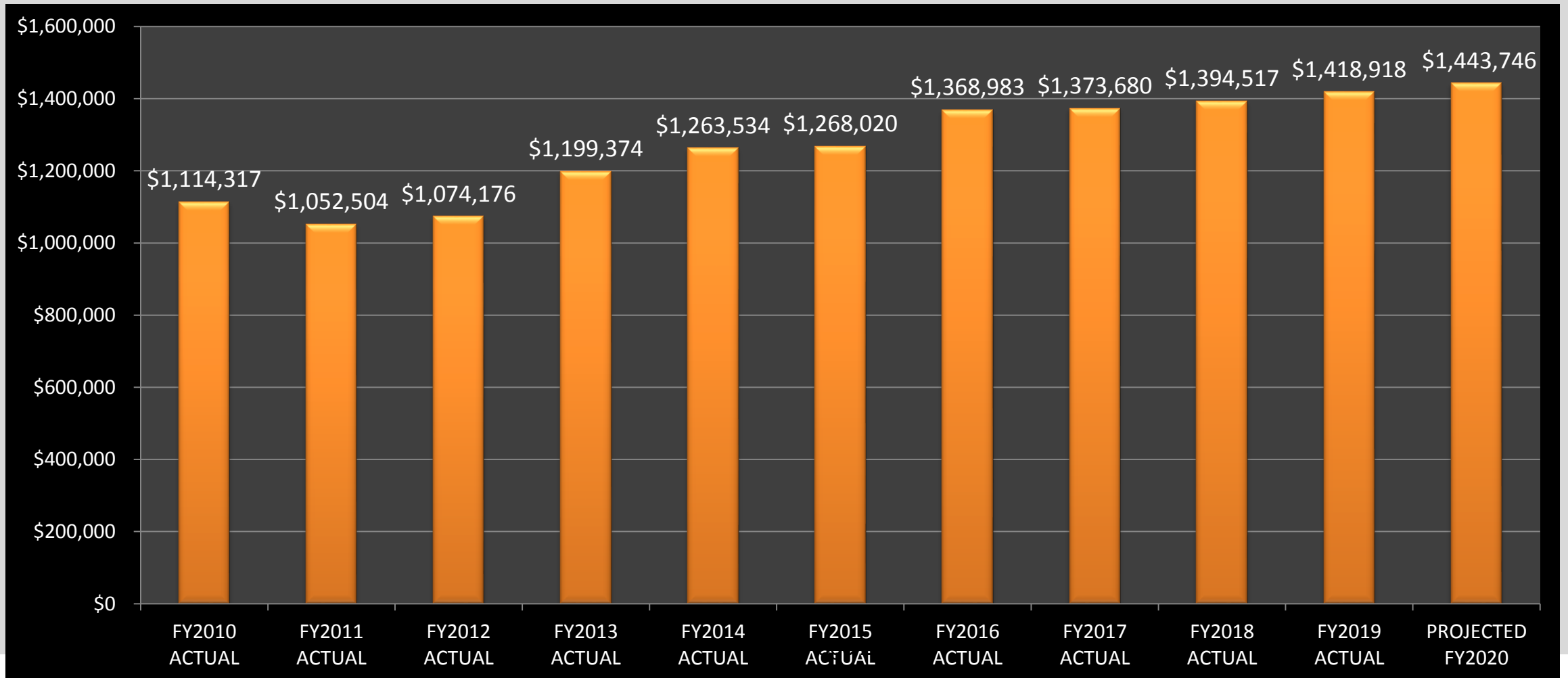

FINANCIAL UPDATE

Budget Priority:

Internal Operations

Strategic Area: Citywide

General Fund Operating Revenues

(Excludes Transfers In)

\$32,000,000
\$30,000,000
\$28,000,000
\$26,000,000
\$24,000,000
\$22,000,000
\$20,000,000

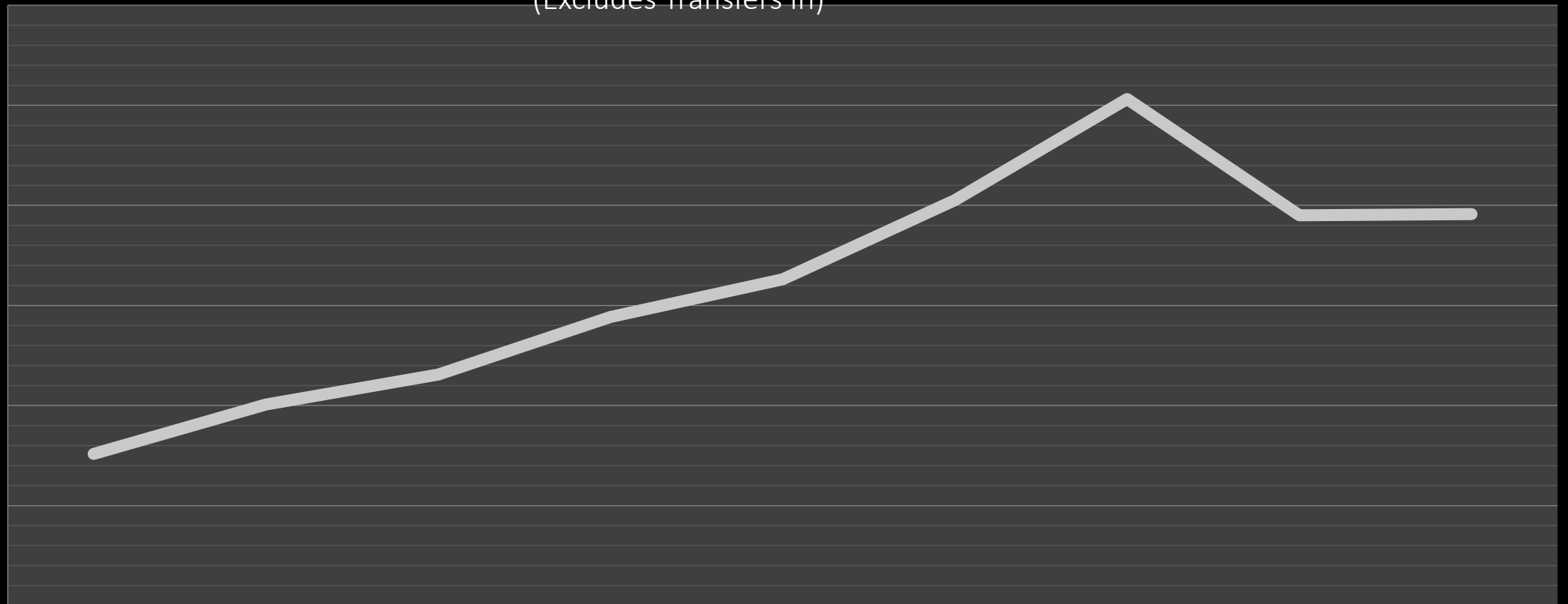

Operating Revenues

\$23,031,768

\$24,020,404

\$24,620,991

\$25,768,418

\$26,520,700

\$28,103,946

\$30,125,099

\$27,798,677

\$27,825,260

FINANCIAL UPDATE

Budget Priority:

Internal Operations

Strategic Area: Citywide

General & Fire Fund - Fund Balance

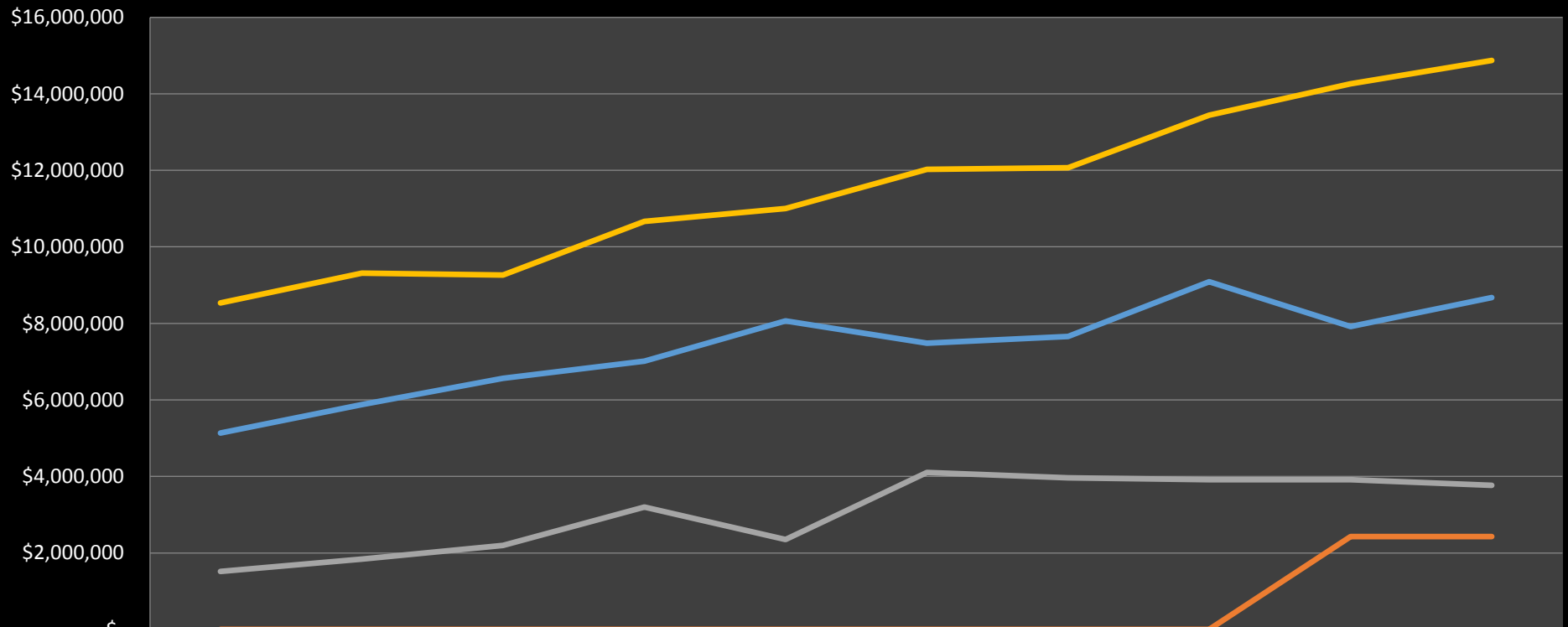

	FY2011	FY2012	FY2013	FY2014	FY2015	FY2016	FY2017	FY2018	FY2019	FY2020 (Estimate)
◆ Unassigned Fund Balance - General	\$5,134,064	\$5,874,076	\$6,565,665	\$7,012,974	\$8,065,121	\$7,480,831	\$7,660,281	\$9,087,006	\$7,916,818	\$8,674,714
■ Unassigned Fund Balance - Fire	\$-	\$-	\$-	\$-	\$-	\$-	\$-	\$-	\$2,431,109	\$2,431,109
▲ Budget Fund Balance	\$1,513,335	\$1,836,732	\$2,200,000	\$3,200,000	\$2,350,000	\$4,100,000	\$3,966,341	\$3,912,390	\$3,916,099	\$3,765,309
✕ Total Fund Balance	\$8,536,244	\$9,309,282	\$9,260,621	\$10,667,293	\$11,003,417	\$12,024,144	\$12,069,935	\$13,442,709	\$14,264,026	\$14,871,132

FINANCIAL UPDATE

Budget Priority:

Internal Operations

Strategic Area: Citywide

General Fund Transfers to Other Funds

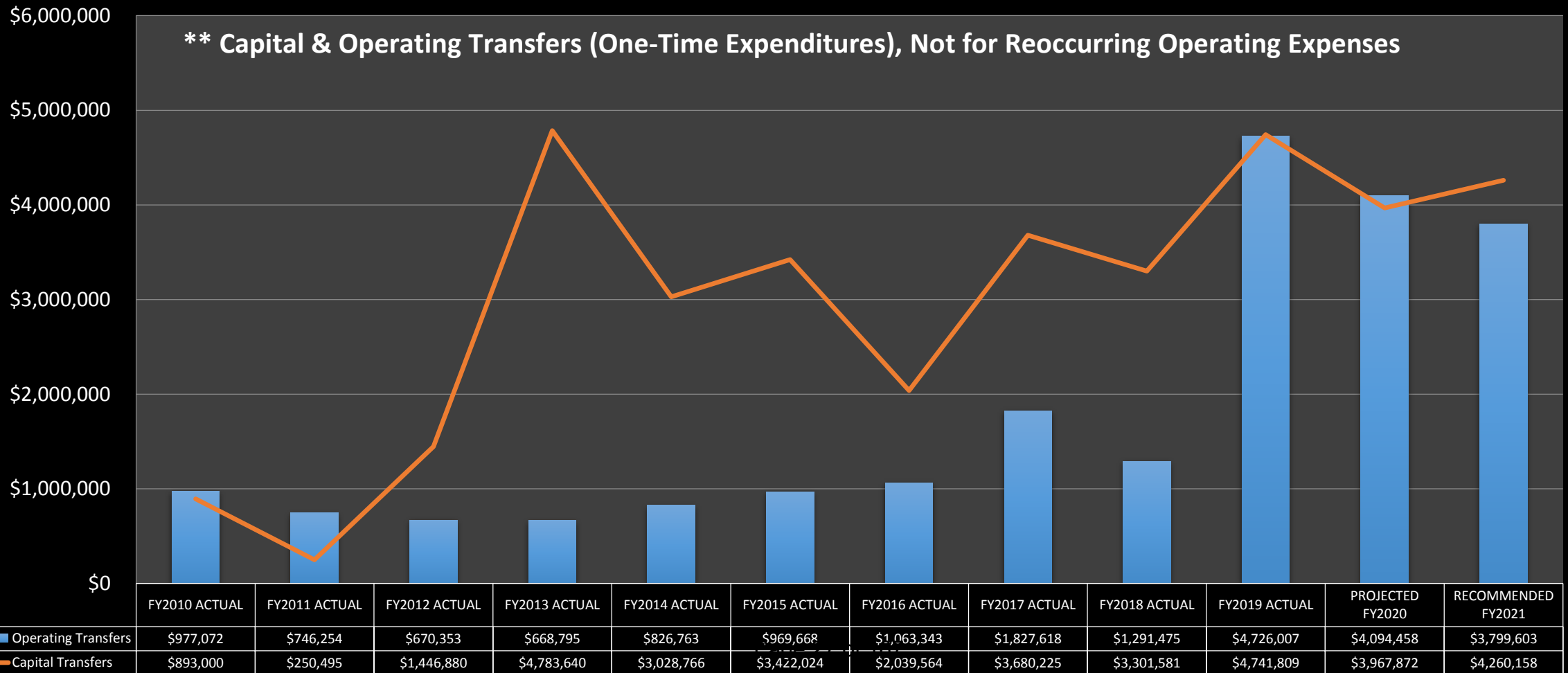

FINANCIAL UPDATE

Budget Priority:

Internal Operations

Strategic Area: Citywide

Estimated Tax Year 2020 (Fiscal Year 2021)	Millage Rates for TY 2020 & FY 2021	Additional Revenue from Reassessments (Estimated 3% Increase)	Additional Revenue from Reassessments (Estimated 3% Increase)	Additional Revenue from Real Growth (Estimated 2% Increase)	Millage Rate Increase (From 0.750 to 0.896)
Fire Fund	1.250	\$168,270	\$0	\$112,180	\$0
General Fund & Debt Service	0.771 & 0.551	\$0	\$177,961	\$118,641	\$0
Parks & Recreation	0.896	\$75,661	\$0	\$50,441	\$728,640
Totals	3.468	\$243,931	\$177,961	\$281,262	\$728,640

ACCOMPLISHMENTS

ACCOMPLISHMENTS

Budget Priority:
Internal Operations
Strategic Area: **Citywide**

Received annual awards for Budget, PAFR and CAFR (with no findings).

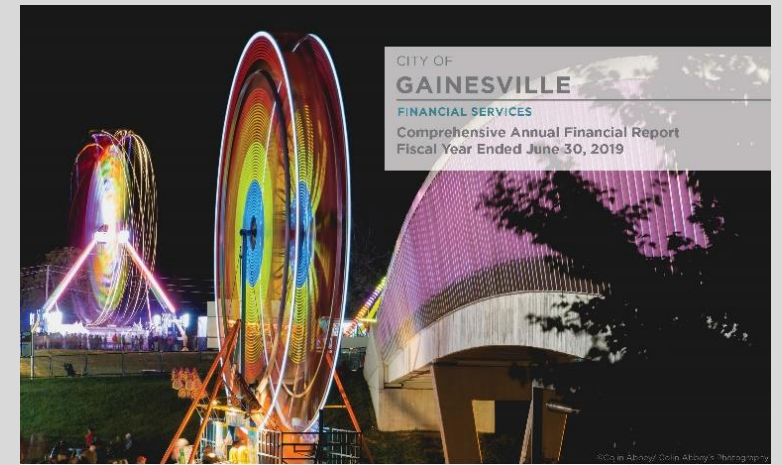
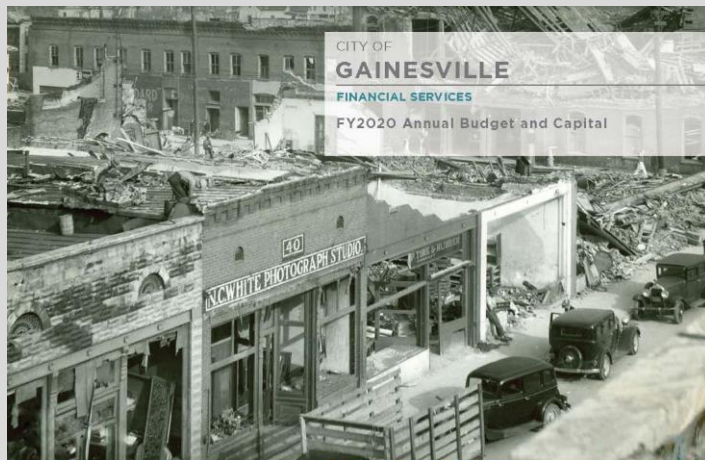

ACCOMPLISHMENTS

Budget Priority:
Internal Operations
Strategic Area: Citywide



ROLLING READING ROOM
Buses filled with books travel region to fill young minds.
Our Region, 1C

MILLIPEDE MIGRATION
Make sure to seal cracks as insects swarm area.
LIFE, 1D



The Times

FRIDAY
March 13, 2020
50 CENTS
GAINESVILLE, GEORGIA

Your news. Your Times. gainesvilletimes.com

City of Gainesville Did It Again!!! Another Year of Solid Financial Statements

BY JOSHUA SILAVENT
jsilavent@gainesvilletimes.com

The Association County Commissioners of Georgia and the Georgia Municipal Association have begun talks to determine whether the process of distributing local option sales tax revenue between counties and cities can be improved and made more equitable.

The last negotiation for Hall County and Gainesville took place in October of last year.

Hall County wound up receiving about 74 percent of LOST revenues while Gainesville received about 17 percent. The rest was split between Flory Branch, Oakwood, Clermont, Lula, Braselton, Buford and Gillsville.

The eight criteria that counties and cities use when negotiating with one another about how to divvy up LOST revenues is vague, at best.

LOST revenue breakdown
■ Hall County 74.40%
■ Clermont 0.49%
■ Flory Branch 2.92%
■ Gainesville 17.38%
■ Gillsville 0.15%
■ Lula 1.34%
■ Oakwood 2.04%
■ Braselton 0.87%
■ Buford 0.49%

■ Please see TAX, 7A

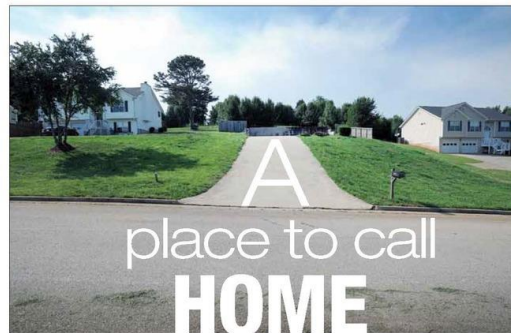

Gainesville – Great place to Live, Work, and Play

Attorneys are set to give opening statements Monday in Hall County Superior Court after selecting jurors for the murder trial of Joseph Scott Williams.

Williams is accused in the June 2013 shooting death of 37-year-old Adrian Thompson outside Pepper's Grocery & Market on E.E. Butler Parkway in Gainesville.

The trial comes a little more than one year after the encounter between the two men on June 3, 2013. Williams was arrested hours later in a traffic stop after a lookout was issued by Gainesville police, who said the 35-year-old shot Thompson multiple times before fleeing down E.E. Butler Parkway.

Williams faces charges of malice murder, felony murder, possession of a gun during the commission of a crime and possession of a gun by a convicted felon.

After a day and a half of questioning, attorneys on Tuesday selected 12 jurors who will decide the case. Additionally three alternates will hear evidence,

CMYK

Net Position – Last 5 Fiscal Years

Fiscal Year	Net Investment in Capital Assets	Restricted Net Position	Unrestricted Net Position	Total Net Position	Revenues over Expenses
2015	\$ 381,589,409	\$ 57,057,694	\$ (2,384,040)	\$ 436,263,063	\$ 16,063,781
2016	393,150,494	75,191,482	(5,256,152)	463,085,824	22,940,202 ¹
2017	408,287,950	85,063,287	4,497,891	497,849,128	26,822,761 ²
2018	441,615,856	91,958,754	2,432,283	536,006,893	40,205,997 ³
2019	460,292,603	95,871,221	17,887,327	574,051,151	38,044,258

- ¹ Increase of \$4.2 million in SPLOST revenues and increase in revenue in Department of Water Resources
- ² Increase in SPLOST revenues, increase in governmental charges for services, reduction of governmental expenditures, and an increase in Department of Water Resources revenue
- ³ Large capital contributions received in FY2018

Notes: - GASB 68 for Pensions was implemented in 2015 resulting in a negative Unrestricted Net Position
- In FY2018, the implementation of GASB 75 for OPEB further reduced Unrestricted Net Position
- Changes in actuarial assumptions reduced the OPEB liability in FY2019 which increased the unrestricted net position.



ACCOMPLISHMENTS

Budget Priority:

Internal Operations

Strategic Area: **Citywide**



New World ERP Design Challenge

New World Software Enhancements

- Cash Receipts
- Capital Asset Management
- G/L Reports

ACCOMPLISHMENTS

Budget Priority:

Internal Operations

Strategic Area: Citywide

Custom Reports and Process Efficiencies

- Audit Report
- Retirement Reports
- Water Bill imports
 - Saves 4 hours every month



ACCOMPLISHMENTS

Budget Priority:
 Internal Operations
 Strategic Area: Citywide

The screenshot displays the 'Budget Accounts' summary for the 2020 budget year. The total entry is \$1,034,866.00, with a 0% change from the previous level. The interface includes navigation tools, a filter for '100.1510.00 - General Fund, Financial Services, Non-Divisional', and a table of budget items with columns for account type, description, attachments, UDF, transactions, spread, and budget amounts.

Account	Description	Attachments	UDF	Transactions	Spread	2020 Director Approval	2020 Budget Team	2020 Entry
511100.001	Full-Time Salaries and Wages ...			✓		\$0.00	\$0.00	\$775,029
511100.002	Full-Time Salaries and Wages ...					\$0.00	\$0.00	\$0
511100.005	Full-Time Salaries and Wages ...			✓		\$0.00	\$0.00	\$5,400
511100.006	Full-Time Salaries and Wages ...					\$0.00	\$0.00	\$0
511100.007	Full-Time Salaries and Wages ...					\$0.00	\$0.00	\$0
511300.002	Over-time Full-Time Premium			✓		\$0.00	\$0.00	\$1
512100.000	Group Insurance Group Insuran...			✓		\$0.00	\$0.00	\$133,327
512200.000	Social Security and Medicare S...			✓		\$0.00	\$0.00	\$11,316
512400.001	Retirement Contributions Plan A			✓		\$0.00	\$0.00	\$103,017
512700.000	Workers' Compensation Worker...			✓		\$0.00	\$0.00	\$1
512900.001	Other Employee Benefits Unifor...			✓		\$0.00	\$0.00	\$1
521200.002	Professional Services Legal			✓		\$0.00	\$0.00	\$1
522200.001	Repairs and Maintenance Annu...			✓		\$0.00	\$0.00	\$1
522200.002	Repairs and Maintenance Gene...			✓		\$0.00	\$0.00	\$1
522200.003	Repairs and Maintenance Equip...			✓		\$0.00	\$0.00	\$1
522200.004	Repairs and Maintenance Vehic...					\$0.00	\$0.00	\$0
522310.000	Rent - Land and Buildings Rent...					\$0.00	\$0.00	\$0
522320.000	Rent - Equipment Rent - Equip...			✓		\$0.00	\$0.00	\$1
523000.003	Other Purchased Services Uns...			✓		\$0.00	\$0.00	\$5,001
523100.001	Insurance Liability			✓		\$0.00	\$0.00	\$1
523200.000	Telephone / Internet Telephone/...			✓		\$0.00	\$0.00	\$1
523210.000	Cable Cable			✓		\$0.00	\$0.00	\$1
523300.000	Advertising Advertising			✓		\$0.00	\$0.00	\$1
523400.000	Printing and Binding Printing an...			✓		\$0.00	\$0.00	\$1
523500.000	Travel Travel			✓		\$0.00	\$0.00	\$1,751

Implemented the Budget Process through our Financial Software (New World).

CHALLENGES + OPPORTUNITIES

CHALLENGES + OPPORTUNITIES

Budget Priority:
Internal Operations
Strategic Area: Citywide

What is next for our Economy?



Could the Coronavirus Cause a Recession (and How)?

The outbreak is disrupting supply chains and ricocheting through financial markets. But a recession is unlikely until consumers react.



Fed to cut U.S. rates next in September 2020, futures indicate



Bloomberg Market Specialists November 27, 2019

BUSINESS

Markets Tech Media Success Perspectives Videos

LIVE TV Ed

Federal Reserve announces first emergency rate cut since the financial crisis

CHALLENGES + OPPORTUNITIES

Budget Priority:
Internal Operations
Strategic Area: Citywide

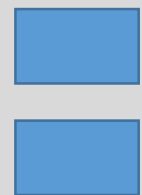

CHALLENGES + OPPORTUNITIES

Budget Priority:

Internal Operations

Strategic Area: Citywide



Credit Card Fraud



Mobile Banking Fraud

ACH Fraud



Local Branch



CHALLENGES + OPPORTUNITIES

Budget Priority:

Internal Operations

Strategic Area: Citywide

SECTION 1.

Chapter 5C of Title 48 of the Official Code of Georgia Annotated, relating to alternative ad valorem taxes on motor vehicles, is amended by revising paragraph (c)(3)(C) of Code Section 48-5C-1, relating to definitions, exemption from taxation, allocation and disbursement of proceeds collected by tag agents, fair market value of vehicle appealable, and report, as follows:

(C) As to the proceeds remaining after the distribution provided for in subparagraph (A) of this paragraph, with regard to the proceeds associated with and collected on motor vehicle titles for motor vehicles registered in the incorporated areas of the county, the tag agent of the county shall within 20 days following the end of each calendar month allocate such proceeds by the municipality from which the proceeds were derived and then, for each such municipality, distribute ~~28~~ 23 percent of such proceeds to the county governing authority and ~~23~~ 28 percent of such proceeds to the governing authority of such municipality, and the remaining 49 percent of such proceeds shall be distributed to the board of education of the county school district; provided, however, that, if there is an independent school district in such municipality, then ~~such~~ 23 percent of such proceeds shall be distributed to the county governing authority and 49 percent of such proceeds shall be distributed to the governing authority of such municipality and the remaining 49 ~~28~~ percent of such proceeds shall be distributed to the board of education of the independent school district."

TAVT Proposed Allocation (HB 779)

	HB329	HB779 Original	HB779 Updated
School District	49%	28%	43%
County	28%	23%	23%
Municipality	23%	49%	34%

CHALLENGES + OPPORTUNITIES

Budget Priority:
INTERNAL OPERATIONS
 Strategic Area: **Citywide**

Property Tax Bill Changes (HB 844)

SECTION 1.

Article 1 of Chapter 5 of Title 48 of the Official Code of Georgia Annotated, relating to general provisions regarding ad valorem taxation of property, is amended by revising Code Section 48-5-33, which is reserved, as follows:

"48-5-33.

(a) All property tax bills issued by the tax commissioner or tax collector for the collection and payment of ad valorem taxes on real property shall include the dollar amount of each tax levied and each credit, if any, for each of the three immediately preceding tax years for which a tax bill was issued for that tax parcel number.

(b) This Code section shall be applicable to all taxable years beginning on or after January 1, 2021. Reserved."



CITY OF
GAINESVILLE

2019 Property Tax Statement
 300 Henry Ward Way, P.O. Box 2496 • Gainesville, Georgia 30503
 Phone (770) 535-5639 • Fax (770) 535-5636
 Pay taxes online at www.gainesville.org

PROPERTY OWNER(S)	MAP CODE		LOCATION		BILL #	DISTRICT	
					2019-1835	004 GAINESVILLE	
	BUILDING VALUE	LAND VALUE	ACRES	FAIR MARKET VALUE	DUE DATE	BILLING DATE	EXEMPTIONS
	5,632,589	2,567,411	10.08	8,200,000	12/01/2019	09/17/2019	(Please see explanation on back)

	FAIR MARKET VALUE	100% ASSESSED	LESS EXEMPTIONS	TAXABLE VALUE	MILLAGE RATE	TAX
GROSS M&O GENERAL AND DEBT SERVICES	8,200,000	8,200,000	0	8,200,000	2.382	19,532.40
SALES TAX ROLLBACK	8,200,000	8,200,000	0	8,200,000	-1.060	-8,692.00
NET M&O GENERAL AND DEBT SERVICES	8,200,000	8,200,000	0	8,200,000	1.322	10,840.40

GENERAL M&O	8,200,000	8,200,000	0	8,200,000	.771	6,322.20
DEBT SERVICE	8,200,000	8,200,000	0	8,200,000	.551	4,518.20
FIRE SERVICES	8,200,000	8,200,000	0	8,200,000	1.250	10,250.00
PARKS AND RECREATION	8,200,000	8,200,000	0	8,200,000	.750	6,150.00
CITY TAX					3.322	\$27,240.40

SCHOOL	8,200,000	8,200,000	0	8,200,000	6.614	54,234.80
SCHOOL TAX					6.614	\$54,234.80

State law requires that local government bill the property owner as of January 1. Property owners that have sold their property are responsible for forwarding the tax bill to the new owner. If taxes are left unpaid, a lien will be filed on the property in the owner's name as of January 1. Also, property owners that have an escrow account with their mortgage company should forward their bill to the mortgage company. The City does not mail bills to mortgage companies.

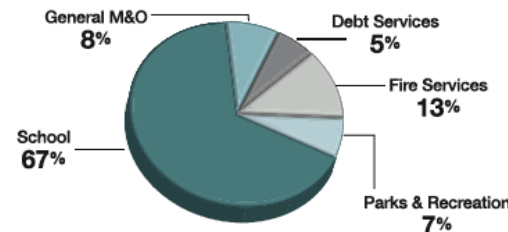

2019 Current Tax	\$81,475.20
Delinquent Tax*	\$0.00
Total Due December 1, 2019	\$81,475.20

* Please note that delinquent tax due reflects total owed at the time of billing and the amount will change monthly due to interest charges. Please read the important information regarding delinquent tax on the back of this bill.

Please see additional information on back regarding delinquent tax and exemption code descriptions

INITIATIVES

INITIATIVES

Budget Priority:

INTERNAL OPERATIONS

Strategic Area: **CITY-WIDE**

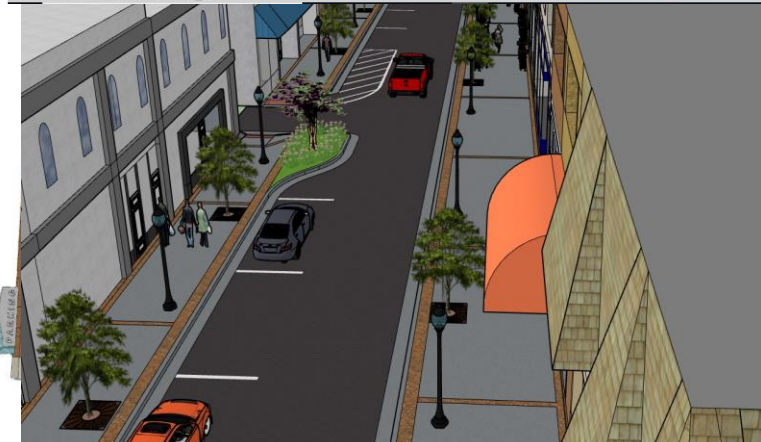
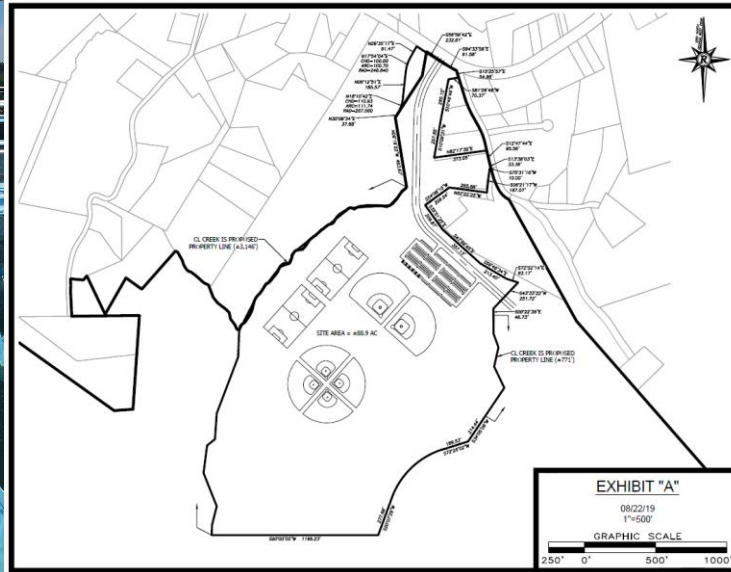
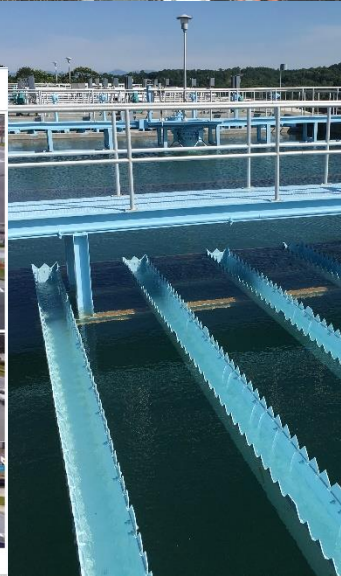

INITIATIVES

Budget Priority:

Internal Operations

Strategic Area: Citywide

Implement GASB
Statement No. 87
pertaining to Leases.

The logo for GASB (Governmental Accounting Standards Board) features the letters 'GASB' in a bold, dark blue, sans-serif font. The letter 'A' is stylized with three diagonal lines crossing through it from the top-left to the bottom-right.

**New Guidance on
Statement No. 87**

INITIATIVES

Budget Priority:

Internal Operations

Strategic Area: Citywide



Update All Financial Reports to a more modern look

- Enhanced Readability
- More transparency

INITIATIVES

Budget Priority:

Internal Operations

Strategic Area: Citywide

Work with new
Financial Advisors
to Increase rating

Currently - Aa2

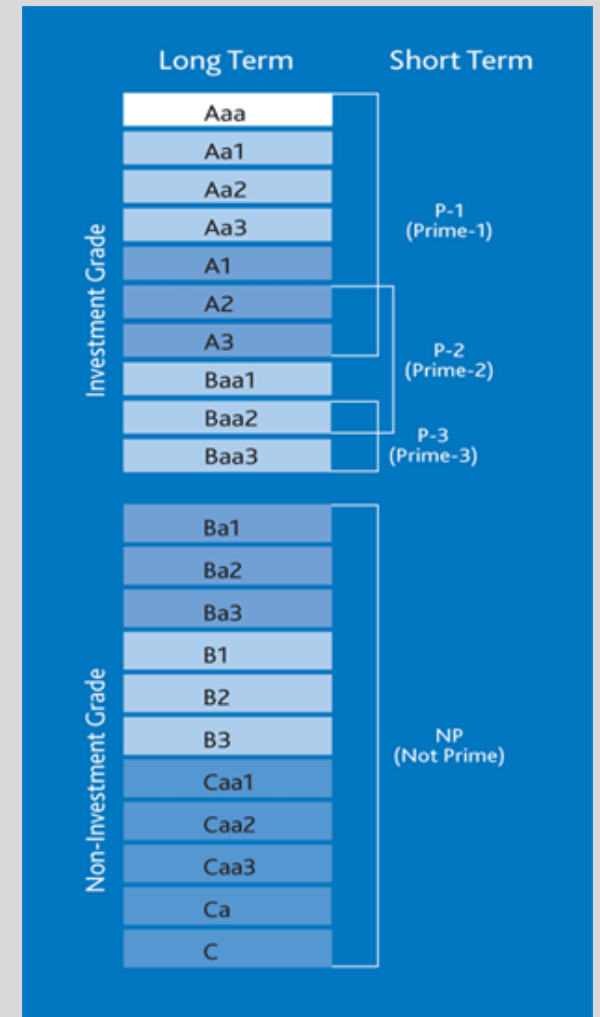

Gainesville (City of) GA

Moody's Org ID: 600024338 LEI: 5493006Y11XKB3GQIF20 6 Digit Cusip: 362874 Market Segment: U.S. Public Finance
Sector: MUNICIPALITY State: Georgia County: Hall County, GA

SENIORMOST TAX BACKED RATING	SENIORMOST REVENUE BACKED RATING	OUTLOOK
Rating: Aa2	Rating: Aa2	Stable
Type: LT SR GO UNDERLYING	Type: LT SR REV UNDERLYING	Date: 31 Aug 2012
Date: 31 Aug 2012	Date: 11 Nov 2014	



QUESTIONS?

 770-533-6898

 JPERRY@GAINESVILLEGA.GOV



CITY OF
GAINESVILLE





GAINESVILLE CITY COUNCIL RETREAT

Fire Department



2020 BUDGET PRIORITIES
FAIR STREET NEIGHBORHOOD CENTER

ACCOMPLISHMENTS

ACCOMPLISHMENTS

Budget Priority:

Operational Improvements

Strategic Area: Citywide

Purchase new 107' aerial tiller truck



Hook & ladder in service



ACCOMPLISHMENTS

Budget Priority:

Operational Improvements

Strategic Area: Citywide

- Completion of the three year radio upgrade
- Drone Program
- 3 Certified Pilots



- Enhancement for search & rescue
- Infrared design
- State of the art communication



ACCOMPLISHMENTS

Budget Priority:

Operational Improvements

Strategic Area: East

- Ground breaking
- Completion summer of 2020



 **PRECISION**
Planning Inc.

GAINESVILLE FIRE STATION NO. 2
Schematic Design Front Perspective View
A19-131 GR25V'B

ACCOMPLISHMENTS

Budget Priority:
Quality of Life
Strategic Area: **Citywide**



- Retained Class #1 rating
- Only 31 in the state
- Less than 200 in the United States



CHALLENGES + OPPORTUNITIES



CHALLENGES + OPPORTUNITIES

Budget Priority:

Internal Operations

Strategic Area: Citywide

Challenges

- Software compatibility
- Reporting

Opportunities

- Update Current software
- Training
- Web based opportunities



CHALLENGES + OPPORTUNITIES

Budget Priority:
Internal Operations
Strategic Area: Citywide

Challenges

- Traffic
- Coverage area increasing
- I.S.O. challenges

Opportunities

- Preemption devices
- Station locations
- Response Changes



CHALLENGES + OPPORTUNITIES

Budget Priority:
Quality of Life
Strategic Area: **Citywide**



TOTAL CALL VOLUME INCREASE SINCE 2008 INCREASE

48%

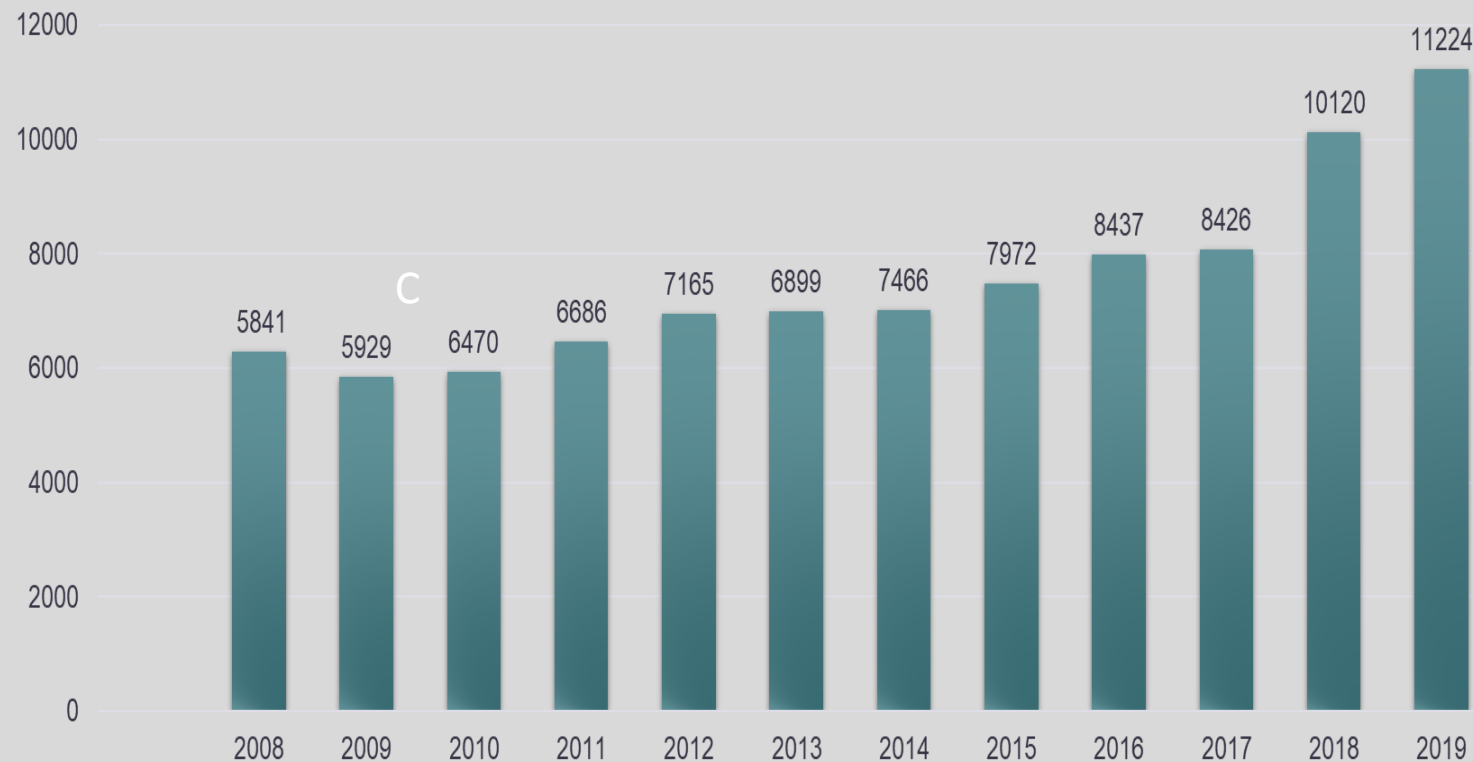

CHALLENGES + OPPORTUNITIES

Budget Priority:

Quality of Life

Strategic Area: Citywide

Challenges

- Quartermaster
- Fleet Maintenance
- Coverage areas

Opportunities

- Manage equipment and supplies
- Certified mechanics
- Cover areas outside 5 miles



CHALLENGES + OPPORTUNITIES

Budget Priority:

Internal Operations

Strategic Area: Citywide

Challenges

- Firefighter Cancer
- PTSD
- Staff Retention

Opportunities

- Health screening
- Certified Counseling
- Competitive Pay & Benefits



INITIATIVES

INITIATIVES

Budget Priority:
Quality of Life
Strategic Area: **Citywide**



Fleet Replacement

Pumper	10 years
Aerial	15 years
Squad	6 years
Staff	8 years

INITIATIVES

Budget Priority:
Quality of Life
Strategic Area: South



Two additional Fire Stations
Southeast (129 cordial)
Southwest (Mundy Mill area)

INITIATIVES

Budget Priority:
Quality of life
Strategic Area: **Citywide**

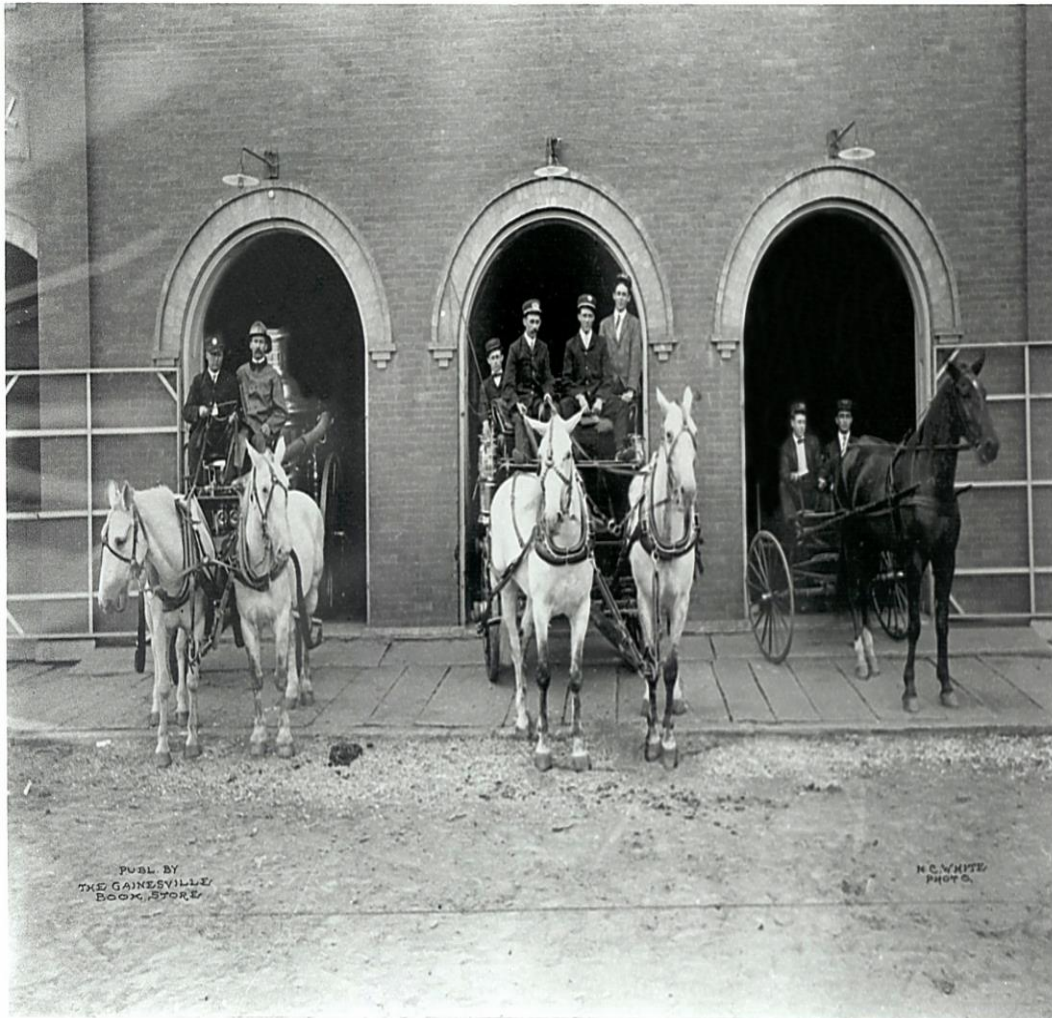

Gainesville Fire Department *Mission Statement*

The Gainesville Fire Department is committed to providing the highest level of fire and public safety services for our community. We protect lives and property through fire suppression, emergency medical response, disaster management, fire prevention and public education.



QUESTIONS?



770-533-5846



JYARBROUGH@GAINESVILLEGA.GOV



CITY OF
GAINESVILLE





Chattahoochee Golf Course

2020 BUDGET PRIORITIES
FAIR STREET NEIGHBORHOOD CENTER



ACCOMPLISHMENTS

ACCOMPLISHMENTS

Budget Priority:

Infrastructure

Strategic Area: **Golf Course**



Construction began on a 40' X 50' maintenance building in early December 2019. Completion should be in late March 2020.

ACCOMPLISHMENTS

Budget Priority:

Leisure Services

Strategic Area: **Golf Course**

A new website for Chattahoochee Golf Course is nearing completion and should launch in mid to late March 2020.



The website is formatted for iPhones, iPads and Android devices. <http://www.chattahoochee.1-2-1beta.com/>

ACCOMPLISHMENTS

Budget Priority:
Leisure Services
Strategic Area: Golf Course



Enhancements to the clubhouse include new photos, original course drawings and new patio furniture.



ACCOMPLISHMENTS

Budget Priority:

Infrastructure

Strategic Area: Golf Course

180 Linear feet of deteriorating cart paths have been replaced.

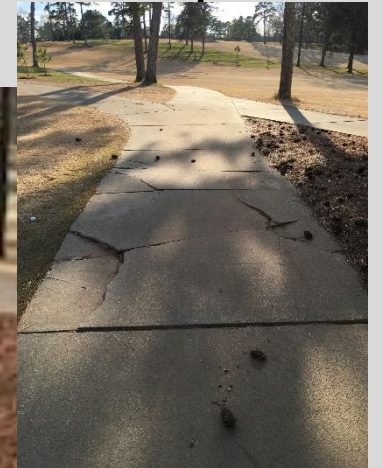



CHALLENGES + OPPORTUNITIES

CHALLENGES + OPPORTUNITIES

Budget Priority:

Infrastructure

Strategic Area: **Golf Course**

In 2017, 10' of additional height was added to the top of the driving range netting. With modern technology, golf balls are flying farther than ever creating a challenge with the driving range. Balls are now being hit over the net, risking damage to cars and injury to residents living across Club Drive. A net 90' tall is needed to deflect 95% of shots hit.



CHALLENGES + OPPORTUNITIES

Budget Priority:

Leisure Services

Strategic Area: **Golf Course**

The new website will give us the ability to offer our patrons the opportunity to book tee times online.

The mobile app interface for booking a tee time on an iPhone. It features a 'Sign In' button at the top right. The main heading is 'Book a Tee Time'. Below this, there are several input fields: 'Date' with a calendar icon and the value '03/05/2020'; 'Time' with a dropdown menu showing 'AnyTime'; 'Course' with a dropdown menu showing 'All selected (4)'; 'Players' with a dropdown menu showing '4'; and 'Holes' with two radio buttons, '9 Holes' and '18 Holes', where '18 Holes' is selected. A 'Search' button is located at the bottom.

iPhone

The desktop website interface for booking a tee time. It features a navigation menu at the top with links for 'GOLF RANGE', 'LESSONS', 'EVENTS', 'JUNIORS', 'GOLF & COUNTRY CLUB', 'OUTINGS', 'WEDDINGS', 'BANQUETS', 'CONTACT', and 'GROWING GREEN'. The main heading is 'BOOK A TEE TIME'. Below this, there are several input fields: 'Date' with a calendar icon and the value '03/05/2020'; 'Time' with a dropdown menu showing 'AnyTime'; 'Course' with a dropdown menu showing 'All selected (4)'; 'Players' with a dropdown menu showing '4'; and 'Holes' with two radio buttons, '9 Holes' and '18 Holes', where '18 Holes' is selected. A 'Search' button is located below the input fields. The search results show three tee time options:

Time	Price	Cart Fee	No.	Players
3:52 PM	\$18.00	\$11.00	No. 1	2 to 4 Players
3:52 PM	\$19.00	\$11.00	No. 3	2 to 4 Players
4:00 PM	\$18.00	\$11.00	No. 1	2 to 4 Players

Desktop

CHALLENGES + OPPORTUNITIES

Budget Priority:

Infrastructure

Strategic Area: Golf Course

Golf Course Architect Bill Bergen has been hired using Friends of Chattahoochee funds to determine the feasibility of re-routing holes #7 and #8. The study also includes re-creating the original Signature 17th hole. The original signature hole was eliminated in the 2007 course renovation.

The re-routing would create potential home sites to be sold on the current 7th fairway, using the proceeds to fund the project.





INITIATIVES



Increase range revenue

Range tokens are currently \$3.00 each.
The price has not had an increase in over 11 years.
An increase to \$3.50 or \$4.00 would have a positive impact on revenues.

The following numbers are based on 17,000 tokens purchased by the public and 8000 by CCC members annually.

Current price \$3.00 = \$64,400.00
Increase to \$3.50 = \$76,630.00 + \$12,190.00
Increase to \$4.00 = \$85,810.00 + \$21,370.00

INITIATIVES

Budget Priority:

Leisure Services

Strategic Area: **Golf Course**



The Pro Shop was painted in 2008 and is in need of updating. An FY21 initiative is to repair and re-paint the Pro Shop to blend in with the grill renovation colors.

INITIATIVES

Budget Priority:

Infrastructure

Strategic Area: **Golf Course**

The teaching center has visible damage and is in need of repair and repainting in FY21.



INITIATIVES

Budget Priority:

Leisure Services

Strategic Area: North



It's amazing that there are still people who have lived in Gainesville for many years that think Chattahoochee Golf Course is private.

We need a new City of Gainesville sign installed at the intersection of Thompson Bridge and Tommy Aaron Drive stating we are open to the public.





QUESTIONS?



770-533-5846



RHOGAN@GAINESVILLEGA.GOV



CITY OF
GAINESVILLE





Community Service Center

2020 BUDGET PRIORITIES
FAIR STREET NEIGHBORHOOD CENTER

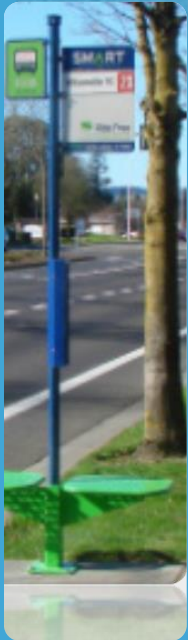
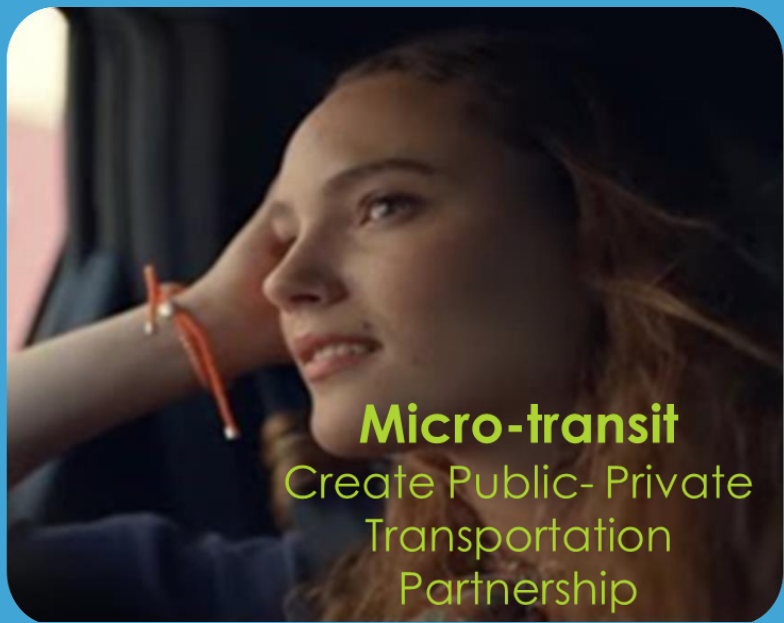

ACCOMPLISHMENTS

ACCOMPLISHMENTS

Budget Priority:
Economic Development
Strategic Area: **Citywide**

HALL AREA TRANSIT

- ✓ Microtransit RFP Released
 - ✓ Multiple Responses
- ✓ Next Steps
 - ✓ Selection
 - ✓ Contract
 - ✓ Implementation

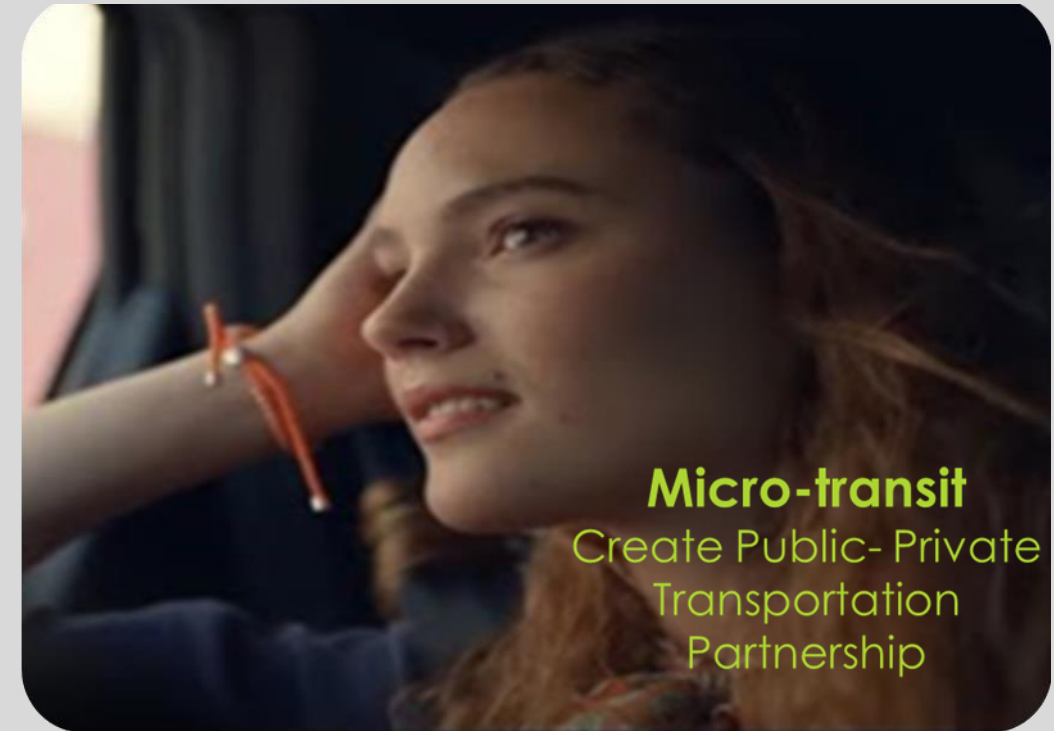
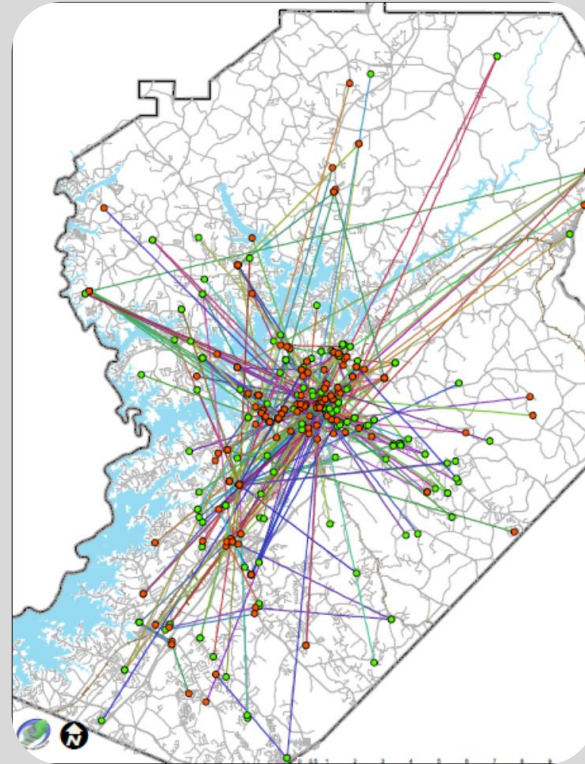

ACCOMPLISHMENTS

Budget Priority:
Economic Development

Strategic Area:
Downtown/Midtown

HALL AREA TRANSIT

- Leverage Capital Grants To...
 - Purchase 2 Hometown Trolleys
 - Purchase New “Transit” Vans
 - Both To Replace Aging Gainesville Connection Buses



ACCOMPLISHMENTS

Budget Priority:

Quality of Life

Strategic Area: **Citywide**

MEALS ON WHEELS

- Completed Renovations to Meals on Wheels Kitchen
- 10,000+ Volunteer Hours
- 62,739 Volunteer Miles Driven
- 500 Households Served
- Continue ZERO WAITING LIST
- 100,000+ Meals Served/Yr



ACCOMPLISHMENTS

Budget Priority:

Quality of Life

Strategic Area: Citywide

SENIOR LIFE CENTER

- 6,000+ Meals Served
- 1,000+ Volunteer Hours
- New Activities Introduced
- Multiple Facility Rentals
- Electronic Communications



2020 CENSUS COMPLETE COUNT COMMITTEE

- Photo Shoots
 - Community Celebrities
 - Children
 - Businesses
- Multiple Presentations
- Billboard, Newspaper & Radio Ads
- Disseminated 100,000 Pieces of Marketing Materials

ACCOMPLISHMENTS

Budget Priority:
Economic Development
Strategic Area: Citywide

2020 CENSUS COMPLETE COUNT COMMITTEE Celebrity Photo Shoot

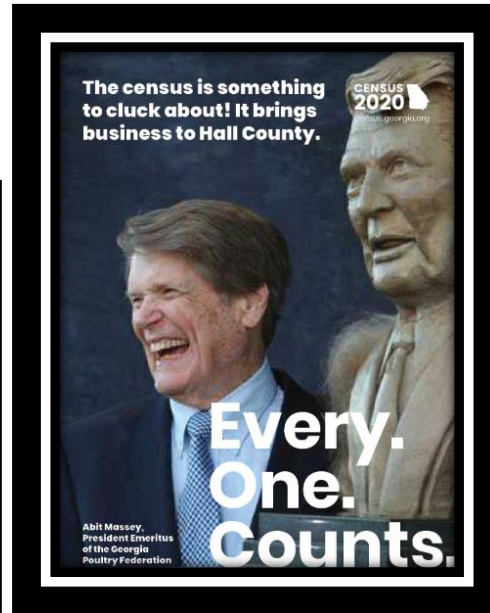
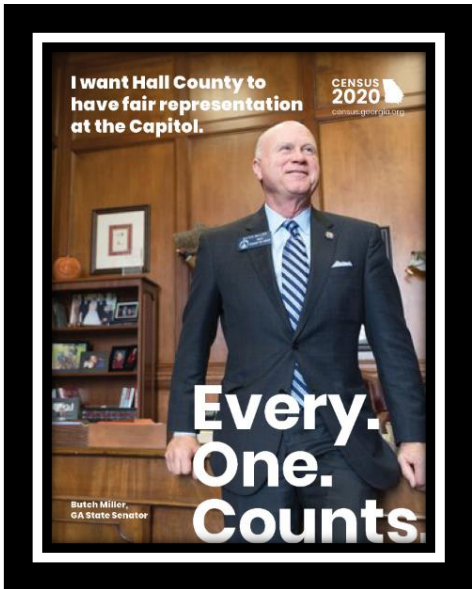

ACCOMPLISHMENTS

Budget Priority:

Internal Operations

Strategic Area: Citywide

2020 CENSUS COMPLETE COUNT COMMITTEE



ACCOMPLISHMENTS

Budget Priority:
Economic Development
Strategic Area: Citywide

2020 CENSUS COMPLETE COUNT COMMITTEE



It's Important.

Our community receives at least \$13,000 for each person counted.

It's Easy.

Fill out online, by mail, or phone.

It's Safe.

Census data cannot be used to identify you and cannot be used against you.

ACCOMPLISHMENTS

Budget Priority:
Internal Operations
Strategic Area: Citywide

Meals on Wheels

Delivering meals and smiles since 1972



Way To Go

Thanks for your donations CITY OF GAINESVILLE family!

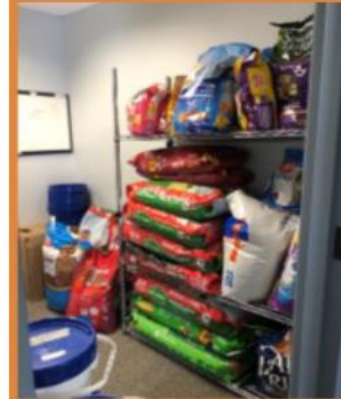

600+ lbs. of DOG FOOD. We will have some happy dogs for the next few months.

197+ lbs. of CAT FOOD. We will be hearing cat purring till Christmas!



We accept donations all year long

ACCOMPLISHMENTS

Budget Priority:

Quality of Life

Strategic Area: Citywide

ACKNOWLEDGING COMMUNITY LEADERS

CSC Staff joined forces with Gainesville-Hall County Community Council on Aging to honor Governor & Mrs. Deal at its 2019 Quality of Life Ceremony!

2019 Community
Quality of Life
Award



Honoring

Governor & Mrs. Nathan Deal

Hosted by the

Gainesville-Hall County

Community Council on Aging

Lanier Tech College - Ramsey Conference Center

November 11, 2019

6-8pm

We Are Better Together

Forging partnerships for a
better Gainesville

ACCOMPLISHMENTS

“The CSC strengthens our community’s human service infrastructure by partnering with and supporting existing nonprofit agencies.”



ACCOMPLISHMENTS

CHALLENGES + OPPORTUNITIES

Budget Priority:
**Quality of Life &
Economic Development**

Strategic Area: **Citywide**

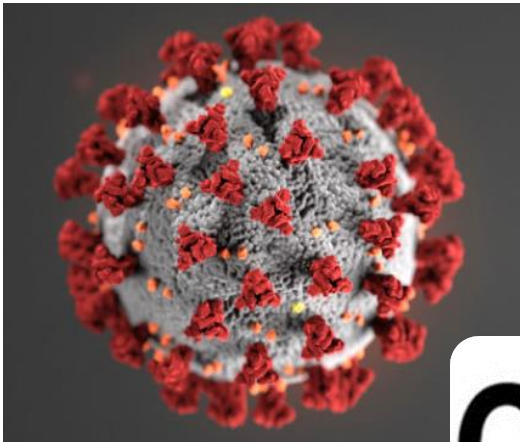

United States
**Census
2020**



- Demand for Fingerprinting Increasing
 - 1721 Fingerprints Processed To Date
- Demand for Meals on Wheels Increasing
 - First Time Exceeding 500 Households
 - Client # Larger Than Atlanta
 - 50+ New Client Requests Each Month
- Corona Virus' Impact on Aging Population
 - Develop Strategies To Protect Population
- Avoid 2020 Census Undercount
 - Every 77 People Equals \$1 Million in Funding We Lose

INITIATIVES

Budget Priority:

Quality of Life

Strategic Area: **Citywide**

- 1. Modernize Transit Fleet**
- 2. Introduce Microtransit**
- 3. Establish A University Fee Structure**
- 4. Expand Wisdom Project To Other Communities**
- 5. Create a Cultural Affairs Committee**
- 6. Expand Senior Services To New Retirees – Silver Tsunami**
- 7. Modernize Senior Services Using Technology**



QUESTIONS?



770-503-3340



PMOSS@GAINESVILLEGA.GOV



CITY OF
GAINESVILLE





Tourism and Public Relations

2020 BUDGET PRIORITIES
FAIR STREET NEIGHBORHOOD CENTER

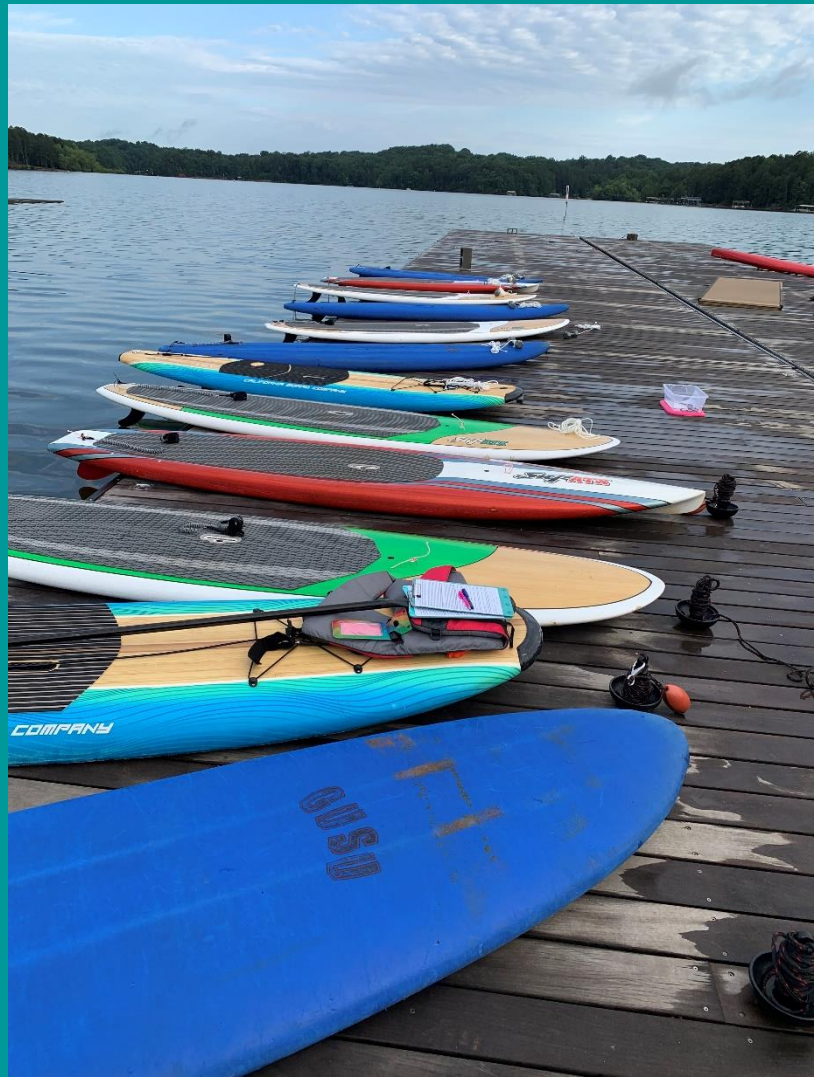

ACCOMPLISHMENTS

ACCOMPLISHMENTS

Budget Priority:
Quality of Life
Strategic Area:
Downtown/Midtown



- ✓ Economic Vitality
 - ✓ Opening of Carroll Daniel Construction
 - ✓ Announcements of development on several key properties in the district
 - ✓ Continued improvements to Midtown Greenway
- ✓ Opening of parking deck restrooms
- ✓ Main Street Events
- ✓ New Main Street Manager, Nicole Ricketts
- ✓ New and improved lighting of downtown for Holidays
- ✓ New and invigorated Main Street members and participation
 - ✓ New and increased interest in Main Street Connections



ACCOMPLISHMENTS

Budget Priority:
Economic Development
Strategic Area:
Downtown/Midtown

- ✓ Creative Marketing Award from Georgia Convention and Visitors Bureau for the Free Range marketing campaign
- ✓ Partnership with Lanier Technical College/Ramsey Conference Center
- ✓ Creation of a MOU and Host Fee Guideline for working with sporting events
- ✓ Complete Staff on Board
- ✓ Creation of the Pearl Nix Mural
- ✓ Collaborated with local hoteliers on overnight packages for local festivals, events and tours
- ✓ New Events and Conferences in 2019
 - ✓ BRAG – 200 room nights
 - ✓ Legacy Ride – 250 room nights
 - ✓ GA Square Dance Association – 750 room nights
 - ✓ ACRA Championships – 1000 room nights



ACCOMPLISHMENTS

Budget Priority:
Internal Operations
Strategic Area:
Downtown/Midtown

- ✓ Public Relations Manager, Christina Santee
- ✓ NCAA Bid Video
- ✓ Expanded communication to public and city staff through website, social media and press releases
- ✓ Collaborated with Tourism staff to successfully plan and execute city sponsored events: Beach Bash, Jingle Mingle, Christmas on Green Street and The Spring Chicken Festival
- ✓ Groundwork laid to roll out new city branding and signage in 2020
- ✓ Mini “Citizens Government Academy” at Cresswind



ACCOMPLISHMENTS

Budget Priority:
Economic Development
Quality of Life
Strategic Area: North

- ✓ Transition to City of Gainesville operations
- ✓ Continued collaboration with rowing and canoe/kayak clubs, events and members
- ✓ 125,000 cars entered the park in 2019 estimating 312,500 visitors
- ✓ Growth of community based events – ex. Food Truck Friday
- ✓ New water based events
 - ✓ World Wake Skate Championships
- ✓ New land based events
 - ✓ American Heart Association – Heart Walk
 - ✓ Bike Ride Across Georgia
 - ✓ Beach Bash





CHALLENGES + OPPORTUNITIES

CHALLENGES + OPPORTUNITIES

Budget Priority:
Internal Operations
Strategic Area:
Downtown/Midtown

- New Director and Staff
 - 5 of 9 staff of less than 6 months
 - 3 out of 5 employees added due to expansion of programs
 - Building relationships inside and outside of City of Gainesville
 - Training on city policies and procedures
- Communication
 - Within the department and full city staff
 - Building and expanding our reach to citizens, business owners, tourism partners and community leaders



Tourism Economic Impact

on

Gainesville/Hall County

2018

\$349,000,000

* From State of Georgia – next projection in spring 2020

Gainesville.org

398,174 users (+14%)

CHALLENGES + OPPORTUNITIES

Budget Priority:
Tourism and Communication
Strategic Area: **Citywide**

Social Followers

- FB CoG
- FB Downtown
- FB Explore
- FB Spring Chicken
- FB LLOP
- Insta Downtown
- Insta Explore
- Insta LLOP

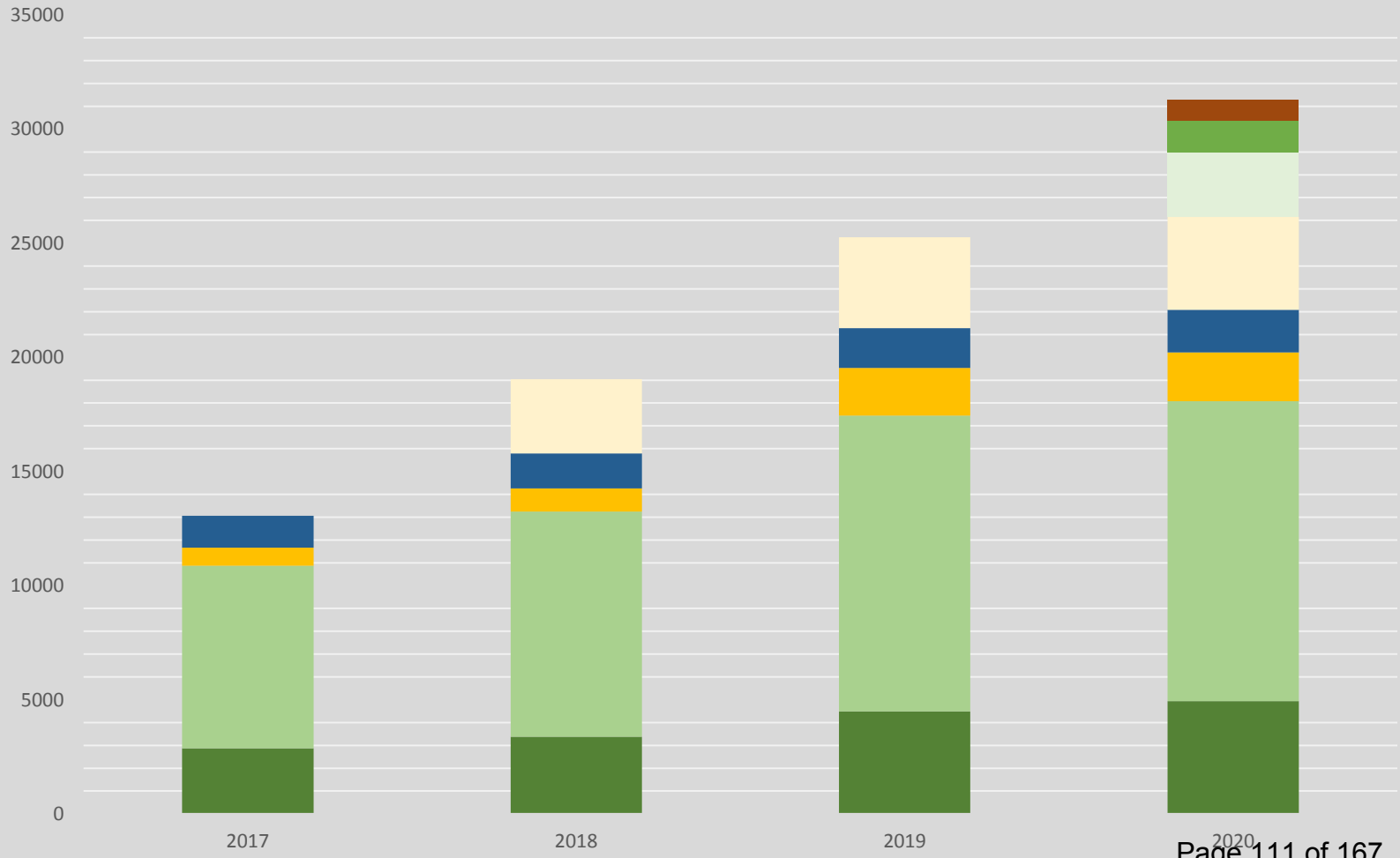

Main Street Gainesville Events

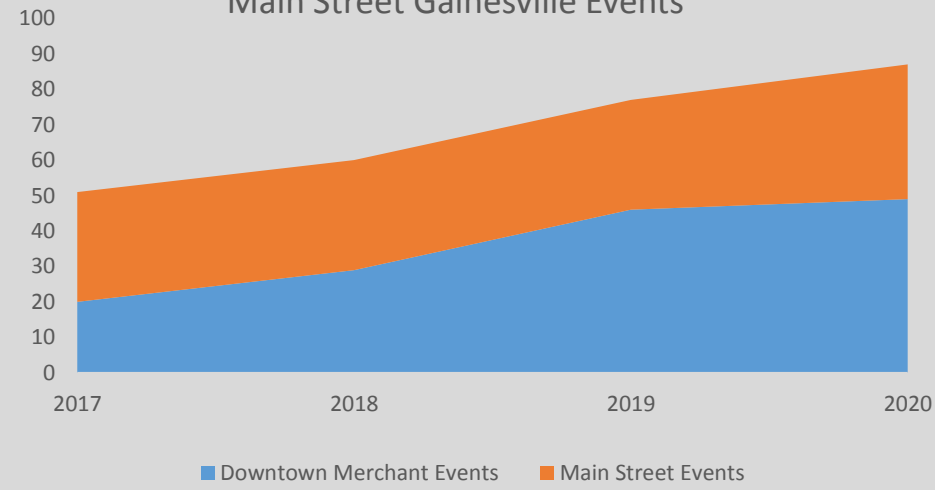

Lake Lanier Olympic Park Events

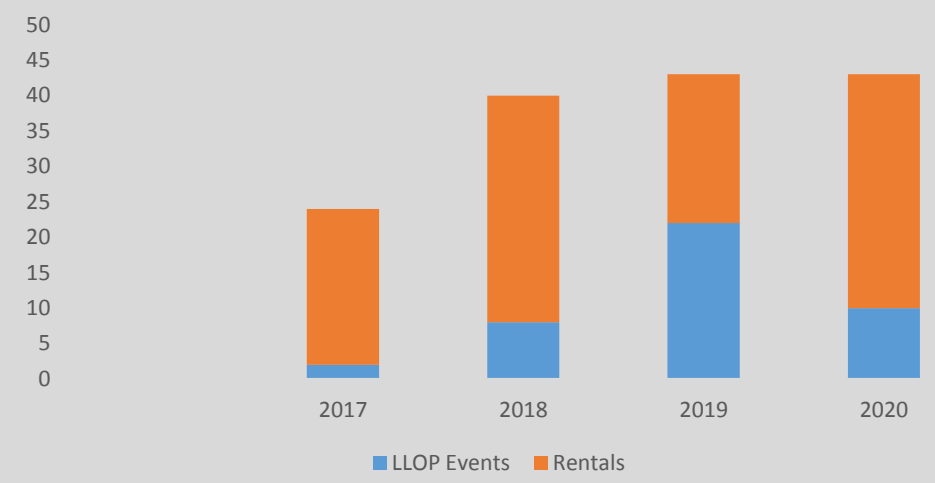



INITIATIVES

INITIATIVES

Budget Priority:
Economic Development

Strategic Area:
Downtown/ Midtown

- Use digital marketing to create a brand identity for Historic Downtown Gainesville and Midland Districts
- Use placemaking concepts to make downtown and midland more unique and inviting
- Develop areas along the Highlands to Islands Trail within the downtown and midtown districts
- Continue to attract new business to available storefronts



- Continue progress on streetscape project and downtown beautification
- Introduce music along the Historic Downtown Square
 - Enticing people to linger downtown shopping, dining and making memories
 - Platform for announcements during festivals and events
 - Communication to consumers and festival attendees about emergency situations (weather alerts, missing child, etc)

INITIATIVES

Budget Priority:
Economic Development
Strategic Area: Citywide



- Creation of Mobile/Digital Kiosk
- Recruitment of 3 conferences/events that produce overnight stays
- Creating Hospitality Information packets customized for each group visiting
- Capturing data after events
- Creation of a City Pass program (discounted tourism partner program)
- Generating new activities to increase hotel/motel overnight stays
- Creation of a Sports Council
- Successfully transition to new visitors center in order to better serve visitors

INITIATIVES

Budget Priority:

Internal Operations

Strategic Area: Citywide

- Continue the Citizens Government Academy to expand the programs reach into the community
- Educate residents on city services, upcoming events, etc. via online communication platforms, including website and social media, with emphasis on increased video/photographic content
- Redesign the city's website so it's easier to access via mobile devices and offers users more services
- Continue to produce and execute city events

new site. new brand
same great
SERVICE

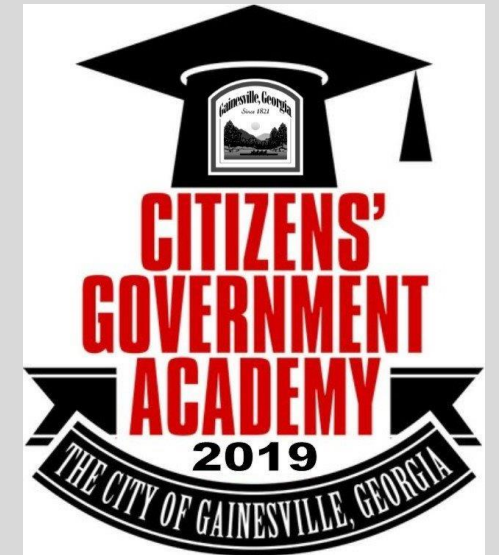

INITIATIVES

Budget Priority:

Quality of Life

Strategic Area: North

- Continue to provide quality services and events, adding new events and rentals
- Insure accountability and safety at LLOP
 - Replace two docks that are deteriorating (installed for the 1996 Olympic Games)
 - Replace the park restrooms built in 1950s that have been locked down since 2015
- Improve communication with the community and stakeholders through marketing, newsletters, and social media
- Continue preparations for renovating the Boathouse
 - Increased revenues from private rentals
 - Increase the number of visiting teams and individual athletes that train at LLOP

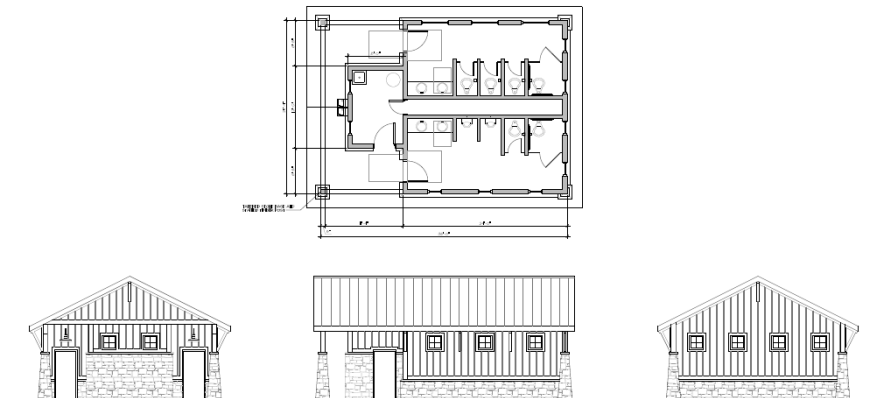
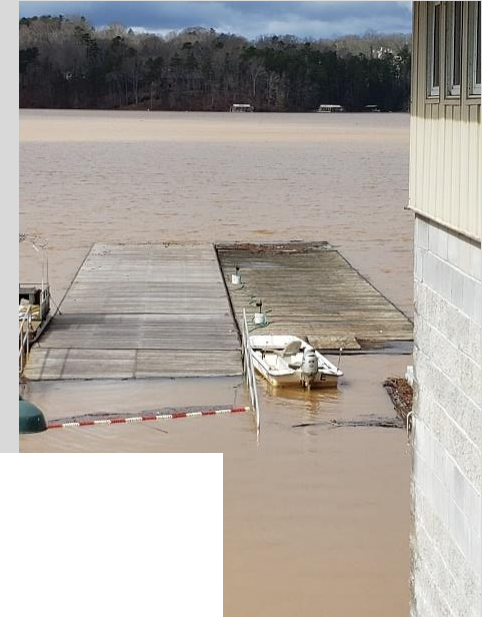



QUESTIONS?

 770-297-5499

 RLYNCH@GAINESVILLEGA.GOV



CITY OF
GAINESVILLE





Police Department

2020 BUDGET PRIORITIES
FAIR STREET NEIGHBORHOOD CENTER

ACCOMPLISHMENTS

ACCOMPLISHMENTS

Budget Priority:

Quality of Life

Strategic Area: **Citywide**



Goal: Strive to improve roadway safety within the City

- 22 Directed Patrols conducted in problem areas
- Motor Vehicle Accidents down **14%!!**
- Positive Citizen connections through SM for traffic alerts!

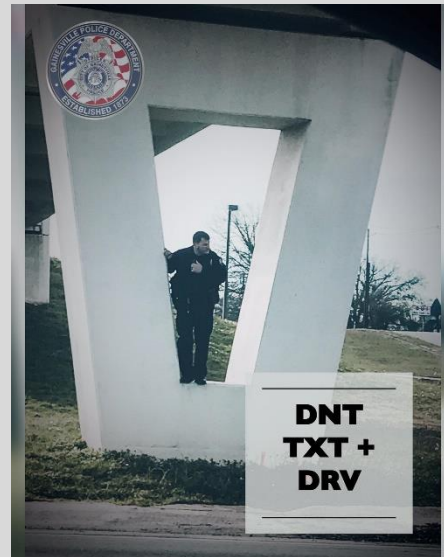

ACCOMPLISHMENTS

Budget Priority:
Quality of Life
Strategic Area: Citywide

Goal: Create Partnerships and Programs Designed to Address Opioid Use

- Guest speakers at four community forums
- Hosted and attended outreach events targeting drug use and prescription takebacks
- Community involvement in several large drug busts

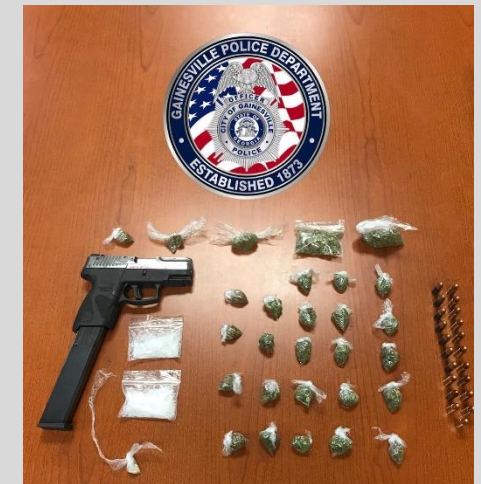
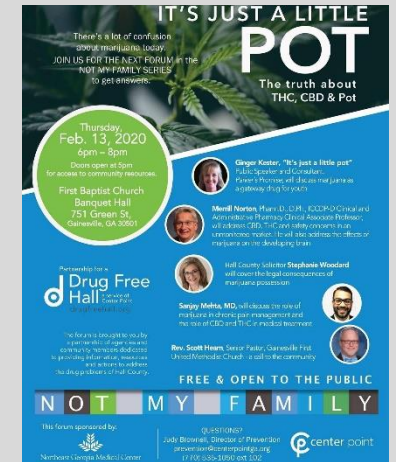

ACCOMPLISHMENTS

Budget Priority:

Quality of Life

Strategic Area: Citywide

GOAL: Address Mental Health Issues Facing LE

- 43 Officers now certified in CIT
- Secured Grant funding for MHC
- Officers trained in Mental Health First Aid

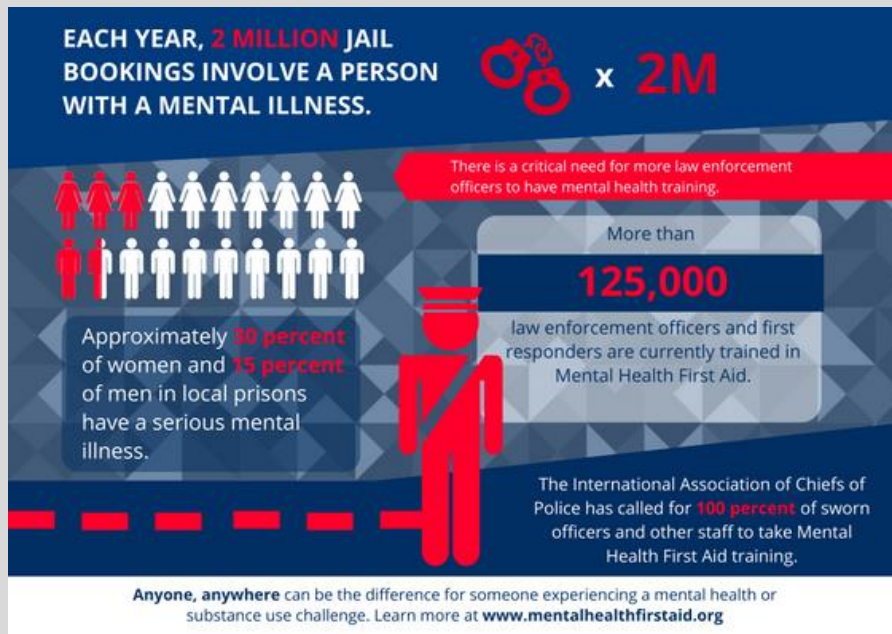

CLINICIANS

Pairing up officers with mental health professionals while dealing with individuals with mental health issues. These professionals would be clinicians specifically available to respond to police calls.



CRISIS-INTERVENTION

Creating a nationwide standard crisis-intervention training program to teach officers to de-escalate conflicts, how to recognize an individual in a mental health crisis and how people behave under the influence of drugs.

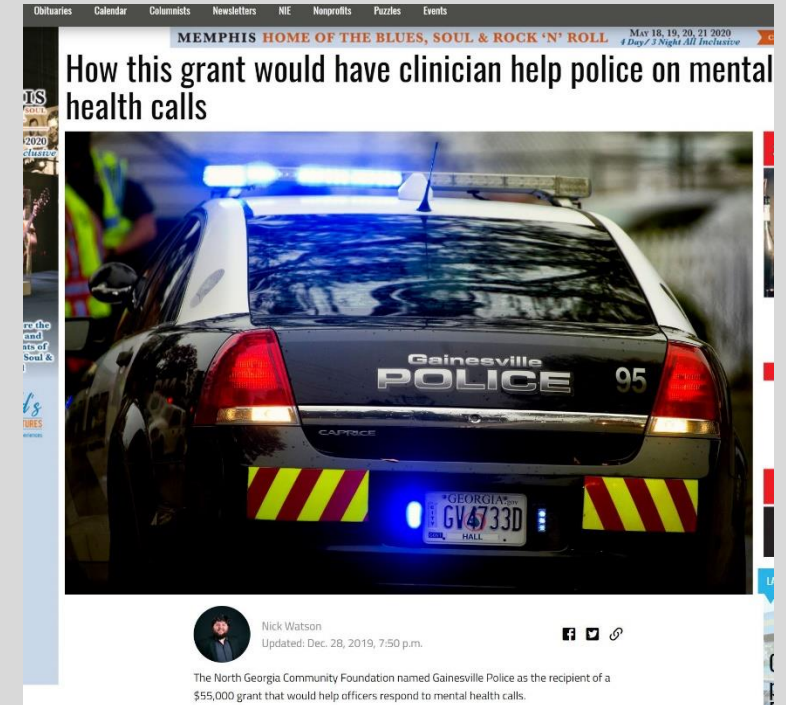

CHALLENGES + OPPORTUNITIES

CHALLENGES + OPPORTUNITIES

Budget Priority:

Quality of Life

Strategic Area: CityWide



Motor Vehicle Accidents and Traffic Flow

Accidents on Major Roadways and related issues
Driver awareness and Rules of the Road Education

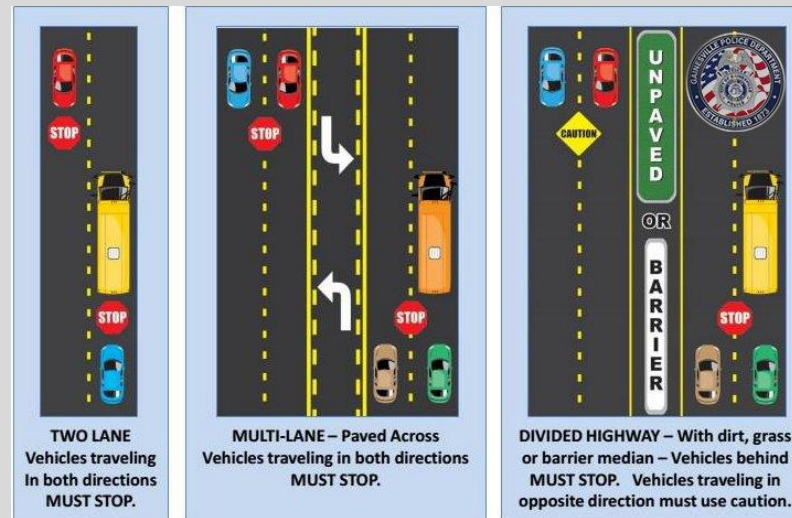

CHALLENGES + OPPORTUNITIES

Budget Priority:
Quality of Life
Strategic Area: Citywide

Mental and Behavioral Health
Patients and LE

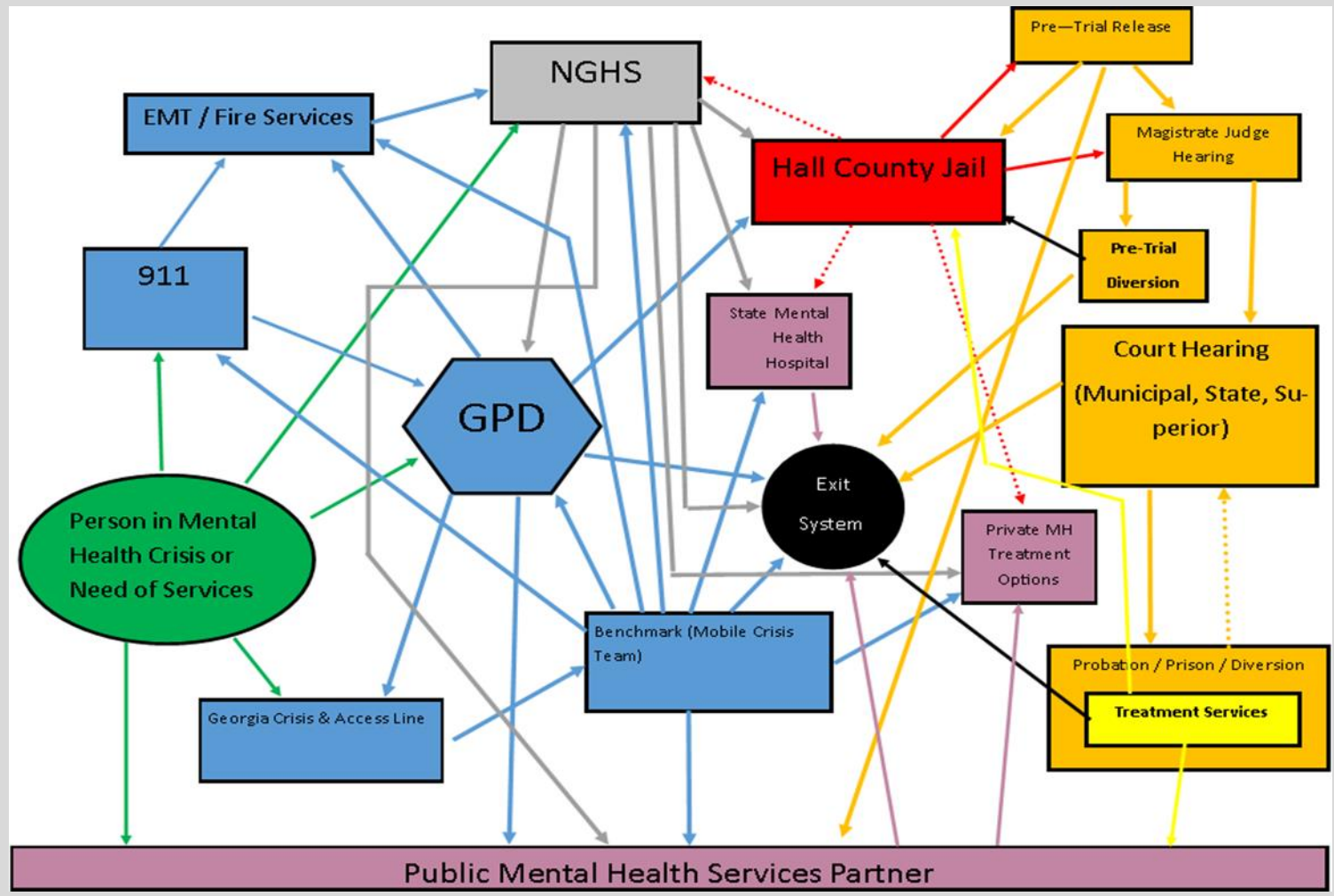

CHALLENGES + OPPORTUNITIES

Budget Priority:
Quality of Life
Strategic Area: Citywide

Youth need positive role-models and programs:



INITIATIVES

INITIATIVES

Budget Priority:

Quality of Life

Strategic Area: Citywide



Roadway Safety:

- Work with citizen groups to raise awareness on distracted and intoxicated driving
- Concentrated Patrols
- Social Media Alerts



INITIATIVES

Budget Priority:

Quality of Life

Strategic Area: **Citywide**

Mental Health Clinician:

Our co-responder program incorporates a fully licensed clinician who will work within the Gainesville City Police Department. The co-responders respond alongside a law enforcement officer when mental illness is identified as a factor. They act as a liaison between the police officer and the community. Additionally, they provide a coordinated community policing response with access to a variety of agencies to assist with severe personal and family concerns signaled by recurring calls for police service related to mental and behavioral health. They assess a client's needs for referral to community-based agencies, mental health agencies, emergency shelters, financial assistance and assistance with on scene crisis intervention.



INITIATIVES

Budget Priority:

Quality of Life

Strategic Area: Citywide

Youth Programs!!

- Mentorship programs with non-profits and community partners
- Community events for youth
- Social Media Blast!

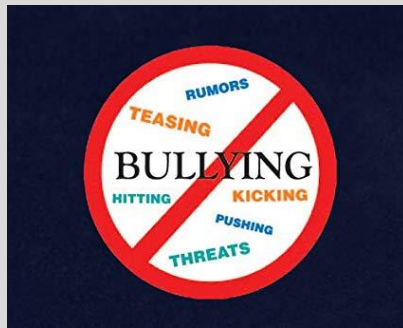



QUESTIONS?



770-533-5846



JPARRISH@GAINESVILLEGA.GOV



CITY OF
GAINESVILLE





Administrative Services

2020 BUDGET PRIORITIES
FAIR STREET NEIGHBORHOOD CENTER

Human Resources

Information Technology

Municipal Court

ACCOMPLISHMENTS

ACCOMPLISHMENTS

Budget Priority:

Internal Operations

Strategic Area: Citywide

Gainesville Leadership Academy



ACCOMPLISHMENTS

Budget Priority:

Internal Operations

Strategic Area: Citywide



Total of 127 employees have joined since 1/1/2020. Total debt eliminated \$92,580 and total savings added \$23,552!

Safety & Benefits Fair



International/Specialty Drug Program

Rolled out in November 2019

Specialty Medications:

- * 13 unique patients
- * Savings of \$158,258

International Medications:

- * 21 unique patients
- * Savings of \$43,231

www.gainesville.org/employees

ACCOMPLISHMENTS

Budget Priority:
Internal Operations
Strategic Area: Citywide

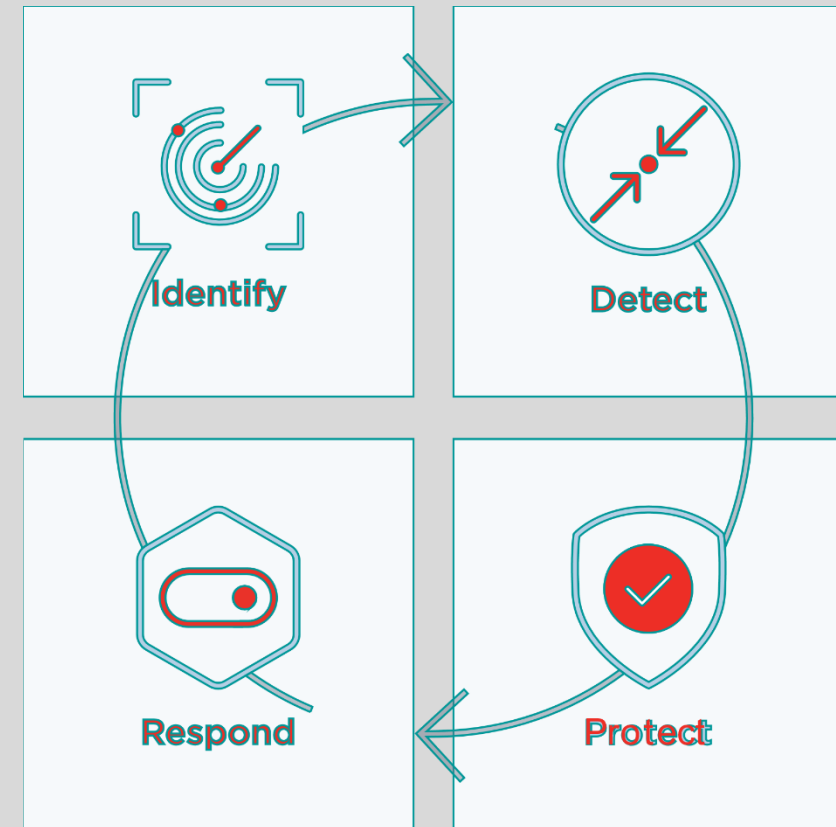

ACCOMPLISHMENTS

Budget Priority:
Internal Operations
Strategic Area: **Citywide**

Working together to make justice work

Internship and Mentoring Program

- ❖ Gainesville High School Work Based Learning
- ❖ 2019 Mock Trial: “Busted Bling Ring”
 - ❖ Centennial Elementary School
- ❖ Police Explorers
- ❖ Professional Mentoring and Development

NACM- National Association for Court Managers
GMCCC- GA Municipal Court Clerks’ Council
GCIC Training Symposium
Judicial Council of Georgia- Administration Office of the Courts
Cities of Oakwood, Cumming and Commerce



Owen Ozaki



ACCOMPLISHMENTS

Budget Priority:

Internal Operations

Strategic Area: Citywide

2019 Municipal Court Caseload Report		
Criminal Category	Cases Filed	Cases Disposed Of
Serious Traffic – DUI	278	299
Serious Traffic – Other	55	71
Misdemeanor – Traffic	9,597	9,820
Misdemeanor – Drugs	121	133
Misdemeanor – Other	267	284
Parking Violations	8	8
Ordinance	274	285
Totals	10,600	10,900

CHALLENGES + OPPORTUNITIES

CHALLENGES + OPPORTUNITIES

Budget Priority:

Internal Operations

Strategic Area: Citywide



In 2020, who's picking who?

Employees have many more choices for job opportunities. They are now choosing us as an employer as thoughtfully as we are choosing them as an employee.

CHALLENGES + OPPORTUNITIES

Budget Priority:
Internal Operations
Strategic Area: Citywide



More feedback
Better pay
Promotional Opportunities

More progressive
Better pay
More time off
Shorter commute

More technology
Better pay
More opportunity for development
Better benefits

Flexible hours
Better pay
More recognition

CHALLENGES + OPPORTUNITIES

Budget Priority:
Internal Operations
Strategic Area: Citywide



CHALLENGES + OPPORTUNITIES

Budget Priority:

Internal Operations

Strategic Area: Citywide

Staying current with technology for Courts

The high-tech courtroom of the future and delivering Justice

- Virtualized and Paperless Courts
- What works best for Gainesville
- Greater use of video evidence
- Technology as a tool for self-represented parties
- Automation and Security
- Delivery of Video Discovery electronically



INITIATIVES

INITIATIVES

Budget Priority:

Internal Operations

Strategic Area: Citywide

To challenge ourselves to think outside the box to create an environment that fosters recruitment and retention of great employees!



Safety Incentive Program

Creating a safer working environment for our employees

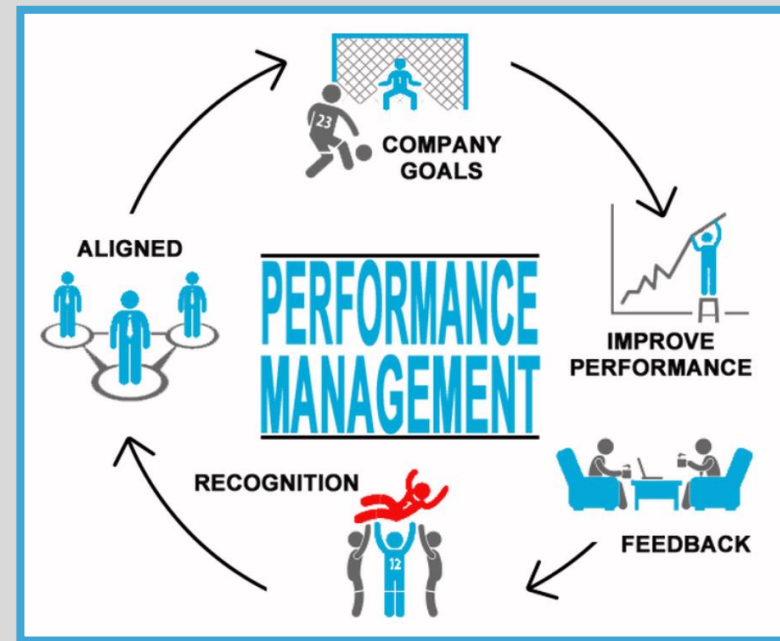

Establish more career ladders

Giving employees more promotional chances and opportunities for development

INITIATIVES

Budget Priority:

Internal Operations

Strategic Area: Citywide

To continue helping our employees become better consumers of their healthcare, while reducing costs for the city.

High Deductible Health Plan
(HDHP)



- *Only offering the HDHP to new employees
- *Prescription plans changes
- *More robust benefits platform system
- *New wellness credit opportunities



INITIATIVES

Budget Priority:

Internal Operations

Strategic Area: **Citywide**



INITIATIVES

Budget Priority:
Internal Operations
Strategic Area: Citywide

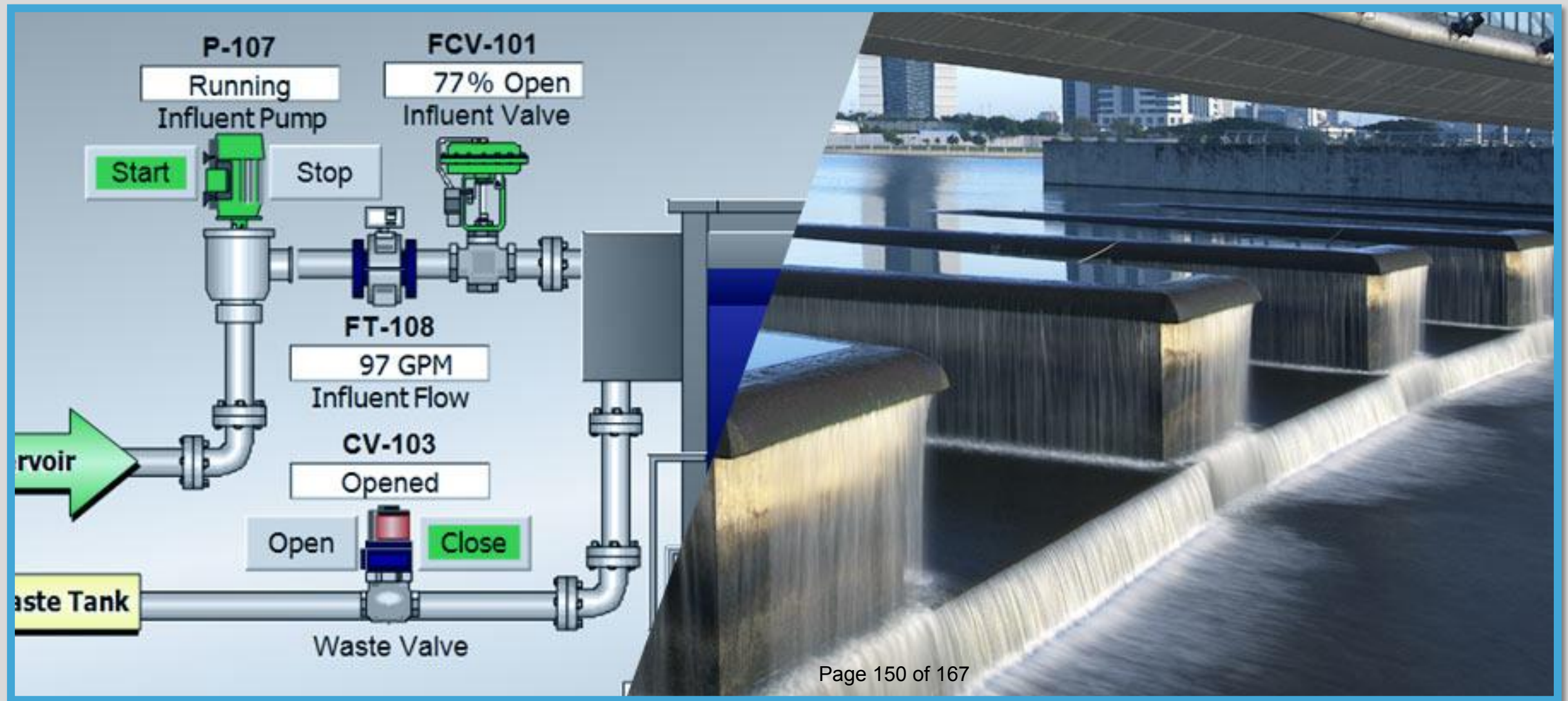

INITIATIVES

Budget Priority:

Internal Operations

Strategic Area: Citywide

Online Dispute
Resolution:
traffic and minor
infraction



Legal Matters
regarding Bond
Forfeitures



QUESTIONS?



770-297-5485



JALLISON@GAINESVILLEGA.GOV



CITY OF
GAINESVILLE





GAINESVILLE CITY COUNCIL RETREAT



2020 BUDGET PRIORITIES
FAIR STREET NEIGHBORHOOD CENTER

ACCOMPLISHMENTS

ACCOMPLISHMENTS

Budget Priority:

Leisure Services/ Quality of Life

Strategic Area: Citywide



CAPITAL PROJECTS

- Skate Park Construction
- City Park Improvements
- 2030 Gainesville Parks, Greenways, and Open Spaces Master Plan
- Roper Park Improvements
- Park Signage Implementation (Phase 2)
- VSI Software Upgrades

ACCOMPLISHMENTS

Budget Priority:
Leisure Services/ Quality of Life
Strategic Area: Citywide



YOUTH SPORTS RECREATION COMPLEX
CONCEPT PLAN



GREEN STREET PARK
CONCEPT PLAN



LONGWOOD PARK
CONCEPT PLAN



MIDTOWN GREENWAY
CONCEPT PLAN



ACCOMPLISHMENTS

Budget Priority:
Leisure Services/Quality of Life
Strategic Area: Citywide

FY19 ANNUAL SNAPSHOT

Fiscal Year 2019 Revenues

Total operating revenues show a \$229,909 (4%) increase from projected.



☑ Gainesville 2030 Parks, Greenways and Open Spaces Master Plan Approved

☑ Plans to Develop a Skate Park and Redevelop City Park Finalized

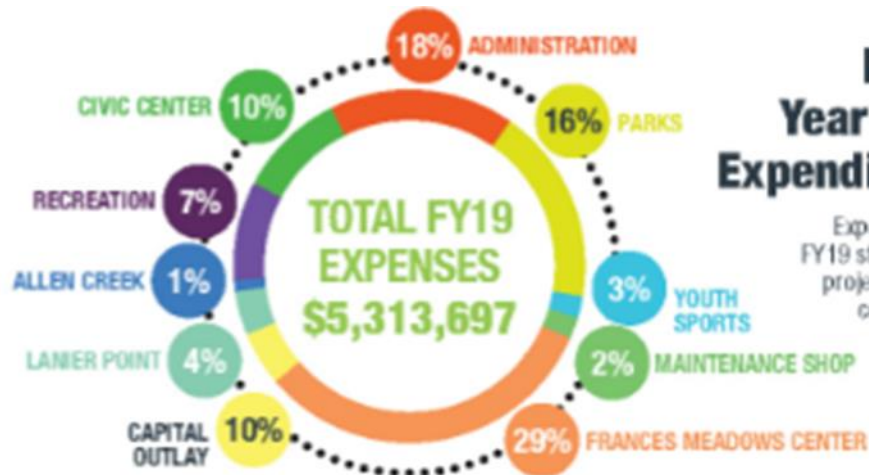

Fiscal Year 2019 Expenditures

Expenditures in FY19 stayed below projections in all cost centers.

MAINTAINS, OPERATES, PROTECTS.
458+ ACRES OF LAND
21 PARKS
20 ATHLETIC FIELDS
14 MILES OF BLUEWAYS
11 MILES OF WALKING TRAILS
15 PUBLIC RESTROOMS
11 PLAYGROUNDS
3 BASKETBALL COURTS
2 AMPHITHEATERS

95% CUSTOMER SATISFACTION RATING

\$17 MILLION ECONOMIC IMPACT
*Includes Lake Lanier Olympic Park

400+ Community Volunteers at a Fiscal Value of \$275K

65% of Revenue Generated from TAXES

35% of Revenue Generated from FEES

National Average 29%

70+ COMMUNITY PARTNERS COMBINING RESOURCES. SAVING MONEY.



Making sure every child plays. More than 1,800 children served.

800,000 ANNUAL PARKS & FACILITY VISITORS

OPERATES FIVE MAJOR COMMUNITY FACILITIES

GAINESVILLE CIVIC CENTER
FRANCES MEADOWS CENTER
LANIER POINT ATHLETIC CENTER
FAIR STREET NEIGHBORHOOD CENTER
MARTHA HOPE CABIN

OVER 100K CITIZENS IN ACTIVITIES THAT

1,000+ RECREATION PROGRAMS OFFERED

200 PART TIME & SEASONAL JOBS CREATED ANNUALLY

MORE THAN 150K RECREATION PARTICIPANTS

CHALLENGES + OPPORTUNITIES

CHALLENGES + OPPORTUNITIES

Budget Priority:

Leisure Services/Quality of Life

Strategic Area: Citywide



- \$10 million in deferred maintenance
- Aging facilities and infrastructure
- J. Melvin Cooper Youth Sports Complex
- Park, Playground, and Restroom Improvements
- Land Acquisition for Recreation Space
- Frances Meadows Fitness Center Improvements
- Green Street Park

INITIATIVES

INITIATIVES

Budget Priority:

Leisure Services/Quality of Life

Strategic Area: Citywide



Our most essential initiative is to follow the 2030 Gainesville Parks, Greenways, and Open Spaces Master Plan recommendations to create an implementation plan that is realistic and attainable over the next ten years.

INITIATIVES

Budget Priority:

Leisure Services/Quality of Life

Strategic Area: **CITYWIDE**

New Facility Initiatives

- J. Melvin Cooper Youth Sports Complex
- Frances Meadows Outdoor Pool Design
- Parks Maintenance Building addition
- Park Restroom addition to Wessell Park
- Park Signage Phase 3



Existing Facility Initiatives

- Midtown Greenway
- Civic Center
- Green Street Park
- Longwood Playground Improvements
- Lanier Point Athletic Complex
- Equipment and Vehicle Repair/Replacement
- Wilshire Trails Pavilion

INITIATIVES

Budget Priority:

Leisure Services/Quality of Life

Strategic Area: Citywide

Operational Initiatives

- Organizational Structure
 - Addressing needs
 - Pending retirements
 - General succession planning
- Innovating
 - New aquatics amenities
 - Recreation programs
 - Marketing
 - Art



**FY2021
Recommended**

PARKS & RECREATION BUDGET SUMMARY

	Actual FY19 (.75 Mills)	Revised FY20 (.75 Mills)	PROPOSED FY21 (.89 Mills)	Variance Change	% Variance
REVENUES					
<i>Non-Departmental</i>					
Property Taxes	3,595,001.10	3,780,828.00	4,635,570.00	854,742.00	22.61%
Interest	75,823.87	26,250.00	68,259.00	42,009.00	160.03%
Parks Development Fund	1,652.66	500.00	500.00	-	0.00%
Miscellaneous & Private Contributions	11,987.12	2,000.00	2,000.00	-	0.00%
Other financing sources/transfers in	17,236.00	94,855.00		(94,855.00)	-100.00%
P&R Capital Project Closeout				-	0.00%
Intergovernmental			450,000.00	450,000.00	100.00%
Transfer from General Fund				-	0.00%
Transfer from Hotel/Motel Fund				-	0.00%
Budgeted Fund Balance			700,000.00	700,000.00	100.00%
Sale of Assets	204,976.80	500.00	500.00	-	0.00%
<i>Departmental</i>					
Charges for Services					
Recreation Services	173,280.80	188,100.00	180,300.00	(7,800.00)	-4.15%
Allen Creek Soccer Complex	15,945.02	18,700.00	16,300.00	(2,400.00)	-12.83%
Civic Center/Facility Services	382,525.04	352,200.00	352,200.00	-	0.00%
Frances Meadows Center	1,005,704.29	1,018,475.00	1,019,000.00	525.00	0.05%
Youth Sports Booster Club	122,392.71	95,600.00	107,250.00	11,650.00	12.19%
Clarks Bridge - LLOP	-	73,700.00	-	(73,700.00)	-100.00%
Lanier Point Athletic Complex	131,094.93	139,550.00	150,950.00	11,400.00	8.17%
TOTAL REVENUES	5,737,620.04	5,791,258.00	7,682,829.00	1,891,571.00	32.66%

EXPENDITURES					
<i>Non-Departmental</i>					
Indirect Costs Allocation	50,000.04	50,000.00	50,000.00	-	0.00%
Other Financial Uses/Capital Outlay	235,000.00	270,000.00	1,750,000.00	1,480,000.00	548.15%
Contributions to other Agencies	160,000.00		300,000.00	300,000.00	100.00%
<i>Departmental</i>					
Maintenance Shop	100,487.09	124,184.00	139,199.00	15,015.00	12.09%
Recreation Division	352,360.31	400,978.00	429,975.00	28,997.00	7.23%
ACSC @ 18%	49,946.21	49,220.00	50,852.00	1,632.00	3.32%
Civic Center	546,614.59	615,354.00	643,423.00	28,069.00	4.56%
Frances Meadows Center	1,549,053.90	1,692,846.00	1,841,669.00	148,823.00	8.79%
YSBC	140,510.86	167,351.00	188,735.00	21,384.00	12.78%
Parks Division	830,755.62	1,037,543.00	1,177,730.00	140,187.00	13.51%
Clarks Bridge - LLOP	-	354,271.00	0.00	(354,271.00)	-100.00%
Lanier Point Park	189,129.15	224,384.00	257,255.00	32,871.00	14.65%
Administrative Division	770,202.95	805,127.00	853,991.00	48,864.00	6.07%
TOTAL EXPENDITURES	4,974,060.72	5,791,258.00	7,682,829.00	1,891,571.00	32.66%
Operating and Maintenance Only	4,739,060.72	5,434,508.00	5,785,329.00	350,821.00	6.46%
Excess Revenue Over Expenses:	763,559.32	0.00	0.00	0.00	



Budget Priority:
Leisure Services/Quality of Life
Strategic Area: Citywide

FY21 Budget Summary
The FY21 Gainesville Parks and Recreation Budget, totaling \$7,682,829, represents an overall increase of 32.66% from the approved, revised FY20 Budget. The increase is related to capital outlay, contributions to other agencies and operations, and is supported through a millage increase and fund balance.



GAINESVILLE CITY COUNCIL RETREAT

QUESTIONS?



770-297-5448



KMATTISON@GAINESVILLEGA.GOV



CITY OF
GAINESVILLE

